

PTAC Direct Sales, Inc.  
185 S. Kimball Ave., Suite 130  
Southlake, TX 76092  
877.454.7822 (T)  
877.647.6408 (F)



## VERTICAL TERMINAL AIR CONDITIONER (VTAC) AND HEAT PUMP

Specifications and Accessories Catalog

Wise Decision.  
It's an Amana® brand.

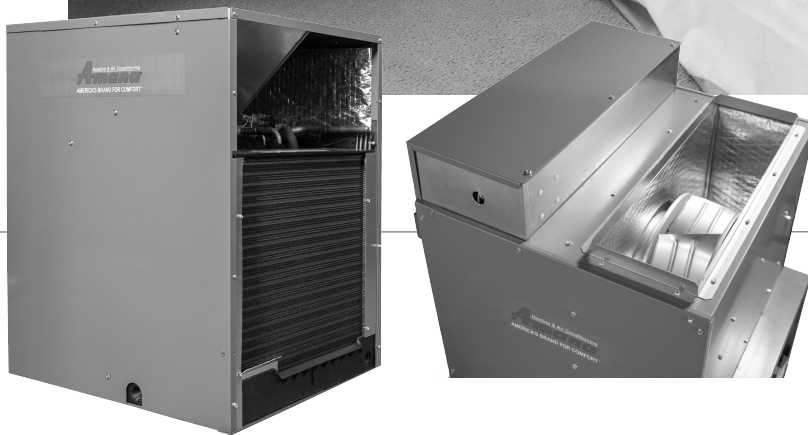

Amana is a registered trademark of Maytag Corporation or its related companies and is used under license. All rights reserved.

Premium Amana®  
Brand Quality

Featuring  
DigiSmart®

Web-Based  
Monitoring

[www.PTACdirect.com](http://www.PTACdirect.com)

## Product Features

- Efficient R32 Refrigerant
- SEER2 and HSPF2 Rated
- Slinger ring technology
- Heat Pump operation down to 10F
- Low-ambient lock-out
- Active Defrost Cycle
- Corrosion resistant blue fin condenser coils
- Safety power disconnect
- Wall-mount thermostat
- Electrical disconnect
- Random unit restart
- Completed insulated cabinet for quiet operation
- “Ductable” to multiple rooms
- Secondary overflow drains
- Closet Mounted
- Base pan heater
- Compressor restart delay
- Rectangular conditioned air opening for all models
- Adjustable fresh air damper
- Telescoping exterior wall adapter
- Floating chassis design
- Self-contained system
- Front, right, or left installations
- Brushless DC motors
- All units 100% run tested
- Up to 765 CFM discharge airflow
- 5 year limited warranty
- Certified to AHRI Standard 210/240

## Nomenclature

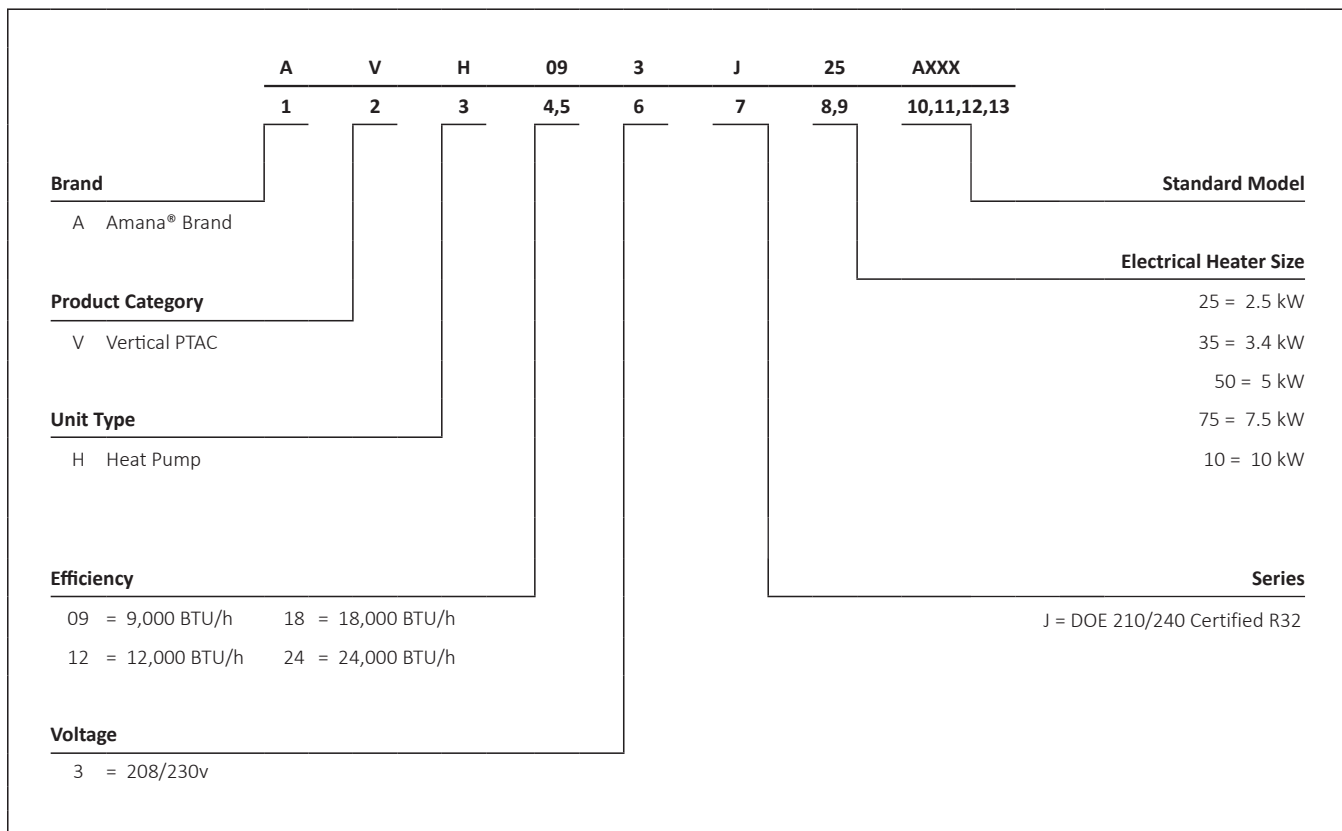

## AVH Model Specifications—Heat Pump/Backup Electric Heat

Model 1,2,3,4,5	AVH093J** AXXX	AVH123J** AXXX	AVH183J** AXXX	AVH243J** AXXX	AVH094J** AXXX	AVH124J** AXXX	AVH184J** AXXX	AVH244J** AXXX	
<b>Cooling Data</b>									
Total Cooling Capacity at 95F (BTU/h)	9,400	11,200	17,800	22,600	9,400	11,200	17,800	22,600	
Sensible Cooling Capacity (BTU/h)	7,100	8,800	13,100	14,700	7,100	8,800	13,100	14,700	
SEER2	12.3	12.3	12.1	12.1	12.3	12.3	12.1	11.9	
EER2	10.6	10.6	10.6	10.6	10.6	10.6	10.6	10.6	
Voltage	208/230	208/230	208/230	208/230	265	265	265	265	
<b>Heating Data</b>									
Heat Pump Capacity at 47F (BTU/h)	8,600	10,400	16,200	19,500	8,600	10,400	16,200	19,500	
Heat Pump Capacity at 14F (BTU/h)	4,900	6,000	9,800	12,400	4,900	6,000	9,800	12,400	
HSPF2	6.3	6.3	6.7	6.7	6.3	6.3	6.7	6.7	
Heater Size Options (kW)	2.5 / 3.4 / 5.0	2.5 / 3.4 / 5.0	2.5 / 3.4 / 5.0 / 7.5	2.5 / 3.4 / 5.0 / 7.5 / 10.0	2.5 / 3.4 / 5.0	2.5 / 3.4 / 5.0	2.5 / 3.4 / 5.0 / 7.5	2.5 / 3.4 / 5.0 / 7.5 / 10.0	
<b>Physical</b>									
Dimensions (W x D x H)	23" x 23" x 32"	23" x 23" x 32"	23" x 23" x 47"	23" x 23" x 52"	23" x 23" x 32"	23" x 23" x 32"	23" x 23" x 47"	23" x 23" x 52"	
Refrigerant	R32								
Volume (OZ)	26.0	28.7	40.0	44.0	26.0	28.7	40.0	44.0	
<b>Airflow Data</b>									
Indoor CFM @ 0.0" ESP	Low	360	360	620	675	360	360	620	675
	High	420	460	705	765	420	460	705	765
Indoor CFM @ 0.1" ESP	Low	325	325	550	600	325	325	550	600
	High	385	430	640	700	385	430	640	700
Indoor CFM @ 0.15" ESP	Low	310	310	510	560	310	310	510	560
	High	370	415	610	670	370	415	610	670
Indoor CFM @ 0.2" ESP	Low	295	295	480	525	295	295	480	525
	High	355	400	585	635	355	400	585	635
Indoor CFM @ 0.25" ESP	Low	270	270	450	490	270	270	450	490
	High	325	380	565	615	325	380	565	615
Indoor CFM @ 0.3" ESP	Low	260	260	400*	440*	260	260	400*	440*
	High	300	350	550	600	300	350	550	600
Indoor CFM @ 0.35" ESP	Low	-	-	365	400	-	-	365	400
	High	-	-	500	540	-	-	500	540
Indoor CFM @ 0.4" ESP	Low	-	-	320	350	-	-	320	350
	High	-	-	450*	490*	-	-	450*	490*
<b>Ventilation</b>									
CFM	Up to 60								

\*Maximum Allowable Static. Units rated at 0.3" ESP.

1. Tested in accordance with AHRI Standard 210/240
2. Minimum voltage on 230/208-volt models is 197 volts; maximum is 253 volts. Minimum voltage on 265-volt models is 239 volts; maximum is 292 volts.
3. Specify two-digit heater kW size to complete model number.
4. R32 refrigerant used in all systems
5. All specifications are subject to change without notice.

## AVH Model Specifications—Electric Heat

Voltage 2,3	Electric Heater Size	Nominal Heating			Total Watts	Electric Heater Amps	Total Electric Heater Amps	Min. Circuit Ampacity 1	MOP (Amps) 1	Power Cord
		at 230V	at 208V	at 265V						
<b>AVH09, AVH12, &amp; AVH18</b>										
230 / 208	2.5 / 2.0	8,300	6,800		2,450 / 2,000	10.7 / 9.6	11.5 / 10.4	14.4	15	Hardwired
230 / 208	3.4 / 2.7	11,400	9,300		3,350 / 2,740	14.6 / 13.2	15.4 / 14.0	19.3	20	Hardwired
230 / 208	5.0 / 4.1	17,000	13,900		5,000 / 4,090	21.7 / 19.7	22.5 / 20.5	28.2	30	Hardwired
230 / 208	7.5 / 6.1	25,500	20,900		7,500 / 6,135	32.6 / 29.5	33.4 / 30.3	41.8	45	Hardwired
265	2.5			8,300	2,450	9.2	10	13.9	15	Hardwired
265	3.4			11,400	3,350	12.6	13.4	16.9	20	Hardwired
265	5			17,000	5,000	18.9	19.7	25.6	30	Hardwired
265	7.5			25,500	7,500	28.3	29.1	36.4	40	Hardwired
<b>AVH24</b>										
230 / 208	2.5 / 2.0	8,300	6,800		2,450 / 2,000	10.7 / 9.6	11.5 / 10.4	14.4	20	Hardwired
230 / 208	3.4 / 2.7	11,400	9,300		3,350 / 2,740	14.6 / 13.2	15.4 / 14.0	19.3	25	Hardwired
230 / 208	5.0 / 4.1	17,000	13,900		5,000 / 4,090	21.7 / 19.7	22.5 / 20.5	28.2	30	Hardwired
230 / 208	7.5 / 6.1	25,500	20,900		7,500 / 6,135	32.6 / 29.5	33.4 / 30.3	41.8	45	Hardwired
230 / 208	10.0 / 8.2	34,400	27,900		10,000 / 8,180	43.5 / 39.3	44.3 / 40.1	55.4	60	Hardwired
265	2.5			8,300	2,450	9.2	10	15.5	20	Hardwired
265	3.4			11,400	3,350	12.6	13.4	18.5	20	Hardwired
265	5			17,000	5,000	18.9	19.7	27.3	30	Hardwired
265	7.5			25,500	7,500	28.3	29.1	36.2	40	Hardwired
265	10.0			34,400	10,000	37.7	38.5	47.9	50	Hardwired

1. Minimum branch circuit ampacity rating conform to the National Electric Code; however, local codes should apply
2. Minimum voltage on 230/208-volt models is 197 volts; maximum is 253 volts. Minimum voltage on 265-volt models is 239; maximum is 292
3. All specifications are subject to change without notice

## Nominal Unit Dimensions

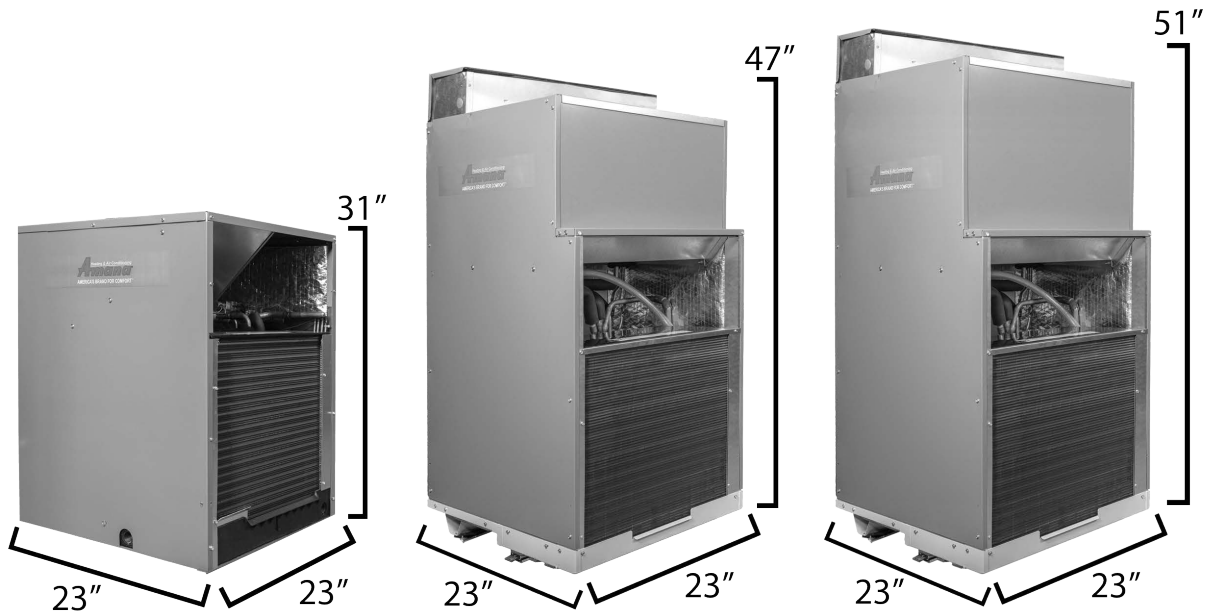

**Applicable Models**  
 AVH09\*\*\*AXXX  
 AVH12\*\*\*AXXX

**Applicable Models**  
 AVH18\*\*\*AXXX

**Applicable Models**  
 AVH24\*\*\*AXXX

## Unit Duct Dimensions



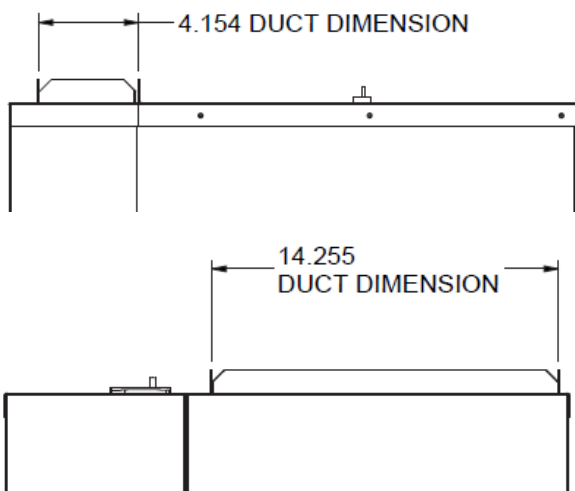

AVH09 & AVH12

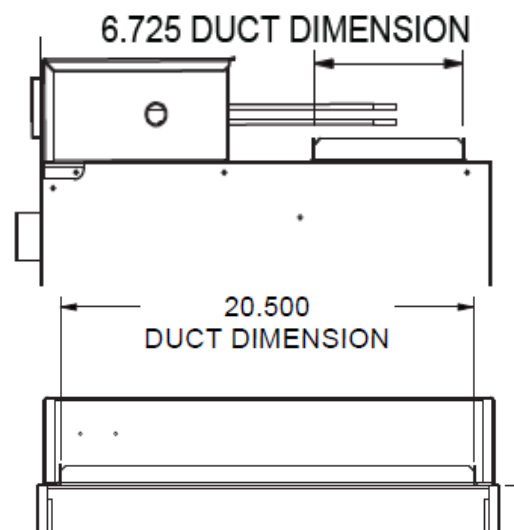

AVH18 & AVH24

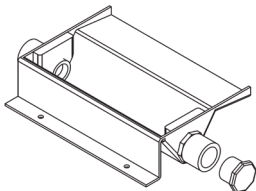
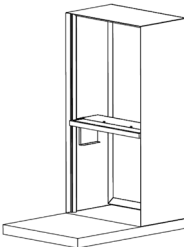

## Accessories

<p><b>EXTERIOR WALL ADAPTOR</b> Two-part sleeve that telescopes in and out from 5 1/2" to 8" in depth for AVEWA05-08A and 8" to 14" in depth for AVEWA08-14A. The wall adapter sits inside the exterior wall penetration.</p>	<p><b>DIMENSIONS:</b> 30 3/8" high x 24 1/8" wide <b>CUTOUT DIMENSIONS:</b> 30 7/8" high x 24 5/8" wide</p> <table border="1"> <tr> <td data-bbox="677 303 836 383">AVEWA05-08A</td> <td data-bbox="836 303 1122 383">Exterior wall adapter that telescopes from 5 1/2" to 8" as required.</td> </tr> <tr> <td data-bbox="677 383 836 463">AVEWA08-14A</td> <td data-bbox="836 383 1122 463">Exterior wall adapter that telescopes from 8" to 14" as required.</td> </tr> </table>	AVEWA05-08A	Exterior wall adapter that telescopes from 5 1/2" to 8" as required.	AVEWA08-14A	Exterior wall adapter that telescopes from 8" to 14" as required.							
AVEWA05-08A	Exterior wall adapter that telescopes from 5 1/2" to 8" as required.											
AVEWA08-14A	Exterior wall adapter that telescopes from 8" to 14" as required.											
<p><b>ARCHITECTURAL LOUVER</b> Extruded aluminum louver that attaches to the outdoor section of the wall adapter.</p>	<p><b>DIMENSIONS:</b> 31 1/16" high x 25 9/16" wide</p> <table border="1"> <tr> <td data-bbox="677 534 836 567">AVAGK01CB</td> <td data-bbox="836 534 1122 567">Anodized Aluminum</td> </tr> <tr> <td data-bbox="677 567 836 599">AVAGK01TB</td> <td data-bbox="836 567 1122 599">Stonewood Beige</td> </tr> <tr> <td data-bbox="677 599 836 631">AVAGK01DB</td> <td data-bbox="836 599 1122 631">Dark Bronze</td> </tr> <tr> <td data-bbox="677 631 836 664">AVAGK01WB</td> <td data-bbox="836 631 1122 664">Amana White</td> </tr> <tr> <td data-bbox="677 664 836 696">AVAGK01SB</td> <td data-bbox="836 664 1122 696">Custom Color</td> </tr> </table>	AVAGK01CB	Anodized Aluminum	AVAGK01TB	Stonewood Beige	AVAGK01DB	Dark Bronze	AVAGK01WB	Amana White	AVAGK01SB	Custom Color	
AVAGK01CB	Anodized Aluminum											
AVAGK01TB	Stonewood Beige											
AVAGK01DB	Dark Bronze											
AVAGK01WB	Amana White											
AVAGK01SB	Custom Color											
<p><b>ACCESS PANEL/RETURN AIR GRILLE</b> Serves as an access panel to chassis and interior return air grille. A field-supplied (25" x 20") filter can be mounted inside the hinged access door. Kit contains hinge bracket for mounting the door with the return air openings high or low on the door for optimal sound attenuation. For 9,000/12,000/18,000 BTU models, it is recommended to install the door with the hinge on the right side and the return air openings high on the door.</p>	<p><b>DIMENSIONS:</b> 58" high x 29" wide <b>CUTOUT DIMENSIONS:</b> 55 3/4" high x 27" wide</p> <table border="1"> <tr> <td data-bbox="677 836 836 890">AVLWP01A-L</td> <td data-bbox="836 836 1122 890">Access Panel/Return Air Grille Hinge pre-installed on left side.</td> </tr> <tr> <td data-bbox="677 890 836 944">AVLWP01A-R</td> <td data-bbox="836 890 1122 944">Access Panel/Return Grille. Hinge pre-installed on right side.</td> </tr> </table>	AVLWP01A-L	Access Panel/Return Air Grille Hinge pre-installed on left side.	AVLWP01A-R	Access Panel/Return Grille. Hinge pre-installed on right side.							
AVLWP01A-L	Access Panel/Return Air Grille Hinge pre-installed on left side.											
AVLWP01A-R	Access Panel/Return Grille. Hinge pre-installed on right side.											
<p><b>ACCESSORY DRAIN PAN/KIT</b> Both left and right-hand connections available. REQUIRED FOR LARGE FRAME VTAC INSTALLATIONS. AVH18 &amp; AVH24</p>	<table border="1"> <tr> <td data-bbox="677 1052 836 1084">AVDK18-2401B</td> <td data-bbox="836 1052 1122 1084">For "H, K, &amp; J" Series Units Accessory Drain Pan/Kit</td> </tr> </table>	AVDK18-2401B	For "H, K, & J" Series Units Accessory Drain Pan/Kit									
AVDK18-2401B	For "H, K, & J" Series Units Accessory Drain Pan/Kit											
<p><b>FIRST COMPANY SLEEVE ADAPTER</b> Designed as a welded adapter allows retrofit of AVH09 and AVH12 units into existing First Company SPXR series SPVU wall sleeve and louver. Not available for AVH18 &amp; AVH24 models.</p>	<table border="1"> <tr> <td data-bbox="677 1289 836 1321">AVAKFC01A</td> <td data-bbox="836 1289 1122 1321">First Company Sleeve Adapter for AVH09 &amp; AVH12 units</td> </tr> </table>	AVAKFC01A	First Company Sleeve Adapter for AVH09 & AVH12 units									
AVAKFC01A	First Company Sleeve Adapter for AVH09 & AVH12 units											
<p><b>DIGITAL WALL THERMOSTAT</b> 3" backlit display with 2 speed fan operation, temperature limiting, and adjustable field calibration</p>	<table border="1"> <tr> <td data-bbox="677 1569 836 1601">PHWT-A150H</td> <td data-bbox="836 1569 1122 1601">Digital Wall Thermostat</td> </tr> </table>	PHWT-A150H	Digital Wall Thermostat									
PHWT-A150H	Digital Wall Thermostat											
<p><b>DIGITAL WALL THERMOSTAT</b> Auto-Changeover and/or Programmable Digital Wall Thermostat - 4 1/4" backlit display with 2 speed fan operation, temperature limiting, and adjustable field calibration</p>	<table border="1"> <tr> <td data-bbox="677 1817 836 1849">PHWT-A200</td> <td data-bbox="836 1817 1122 1849">Digital Wall Thermostat</td> </tr> </table>	PHWT-A200	Digital Wall Thermostat									
PHWT-A200	Digital Wall Thermostat											

## Accessories Contd.

<p><b>Wireless RF Energy Management Controls</b>          Eden Energy Managements Controls operating on 2.4 Ghz 802 15.4 Radio Frequency allows units to be configured for energy management. You can also control and monitor your entire property with the optional DL01G Web enabled platform.</p>	<table border="1"> <tr> <td>DS01G</td> <td>Thermostat: 2-way<sup>2</sup> Communications</td> </tr> <tr> <td>DD01E</td> <td>Occupancy Sensor: EMS Activation<sup>2</sup></td> </tr> <tr> <td>GT01H</td> <td>Generic Radio Antena/ Router<sup>3</sup></td> </tr> <tr> <td>DD01F</td> <td>Door Switch: EMS Activation<sup>2</sup></td> </tr> <tr> <td>DP01G</td> <td>Web-enabled Platform Server</td> </tr> <tr> <td>DL01G</td> <td>Web-enabled Platform Server Link BAC-NET capable</td> </tr> <tr> <td>DR01G</td> <td>Mesh Repeater<sup>1</sup></td> </tr> <tr> <td>DL01G-SERIEAL</td> <td>Serial Repeater<sup>1</sup></td> </tr> </table>	DS01G	Thermostat: 2-way <sup>2</sup> Communications	DD01E	Occupancy Sensor: EMS Activation <sup>2</sup>	GT01H	Generic Radio Antena/ Router <sup>3</sup>	DD01F	Door Switch: EMS Activation <sup>2</sup>	DP01G	Web-enabled Platform Server	DL01G	Web-enabled Platform Server Link BAC-NET capable	DR01G	Mesh Repeater <sup>1</sup>	DL01G-SERIEAL	Serial Repeater <sup>1</sup>	
DS01G	Thermostat: 2-way <sup>2</sup> Communications																	
DD01E	Occupancy Sensor: EMS Activation <sup>2</sup>																	
GT01H	Generic Radio Antena/ Router <sup>3</sup>																	
DD01F	Door Switch: EMS Activation <sup>2</sup>																	
DP01G	Web-enabled Platform Server																	
DL01G	Web-enabled Platform Server Link BAC-NET capable																	
DR01G	Mesh Repeater <sup>1</sup>																	
DL01G-SERIEAL	Serial Repeater <sup>1</sup>																	
<p><b>Discharge Adapter</b>          Adapter to convert factory rectangular discharge duct into standard 10" circular duct connection</p>	<table border="1"> <tr> <td>AVDTK18-24A</td> <td>AVH18 &amp; 24 Discharge Adapter</td> </tr> <tr> <td>AVDTK09-12A</td> <td>AVH09 &amp; 12 Discharge Adapter</td> </tr> </table>	AVDTK18-24A	AVH18 & 24 Discharge Adapter	AVDTK09-12A	AVH09 & 12 Discharge Adapter													
AVDTK18-24A	AVH18 & 24 Discharge Adapter																	
AVDTK09-12A	AVH09 & 12 Discharge Adapter																	
<p><b>Extra Deep Filter Brackets</b>          Replacement bracket to accommodate 2" or 4" deep filters</p>	<table border="1"> <tr> <td>AMAVPFK0912-2</td> <td>Small Chassis 2" Filter Bracket</td> </tr> <tr> <td>AMAVPFK0912U</td> <td>Small Chassis 4" Filter Bracket</td> </tr> <tr> <td>AMAVPFK1824-2</td> <td>Large Chassis 2" Filter Bracket</td> </tr> <tr> <td>AMAVPFK1824U</td> <td>Large Chassis 4" Filter Bracket</td> </tr> </table>	AMAVPFK0912-2	Small Chassis 2" Filter Bracket	AMAVPFK0912U	Small Chassis 4" Filter Bracket	AMAVPFK1824-2	Large Chassis 2" Filter Bracket	AMAVPFK1824U	Large Chassis 4" Filter Bracket									
AMAVPFK0912-2	Small Chassis 2" Filter Bracket																	
AMAVPFK0912U	Small Chassis 4" Filter Bracket																	
AMAVPFK1824-2	Large Chassis 2" Filter Bracket																	
AMAVPFK1824U	Large Chassis 4" Filter Bracket																	



## A legacy of comfort

The impeccable reputation of an American original

Amana heating and cooling systems are a part of the enduring legacy of one of America's most recognized and respected brands. Originating eight decades ago in Amana, Iowa, the brand is synonymous with long-lasting, premium-quality products — from home appliances to heating and air conditioning equipment. Chances are, you and generations before you have enjoyed the dependable performance and longevity the Amana brand continues to deliver.



Call your Amana brand PTAC sales representative at **800-647-2982** for complete details.

Before purchasing this appliance, read important information about its estimated annual energy consumption, yearly operating cost, or energy efficiency rating that is available from your retailer.

**[www.amana-ptac.com](http://www.amana-ptac.com)**

Our continuing commitment to quality products may mean a change in specifications without notice. ©2025 Goodman Manufacturing Company, L.P. Amana is a registered trademark of Maytag Corporation or its related companies and is used under license. All rights reserved.

# Exterior Wall Adapter, Louver and Drain Pan INSTALLATION INSTRUCTIONS

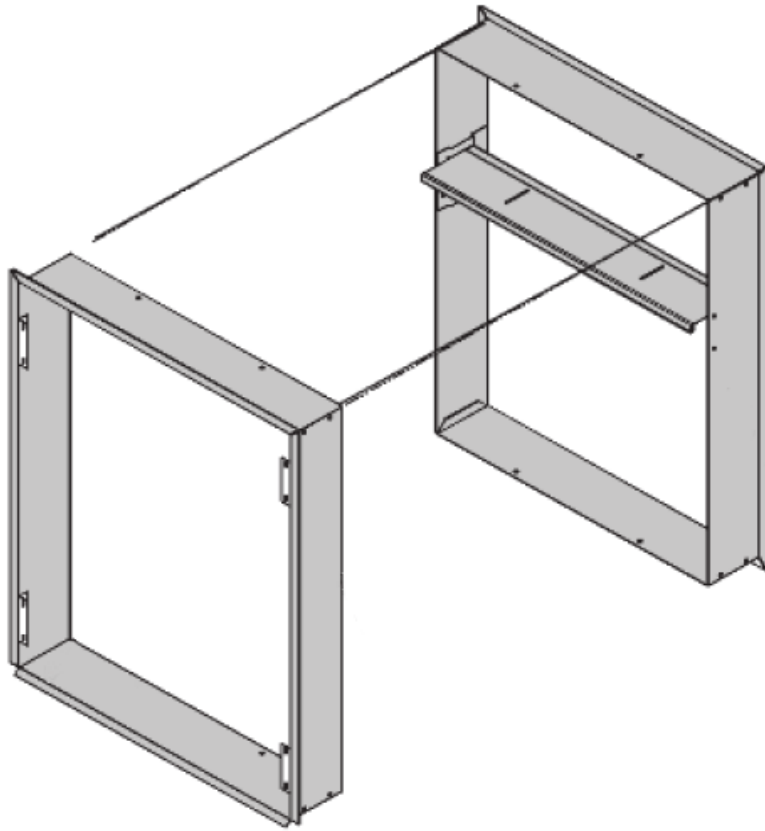

## Table of Contents

Exterior Wall Adapter and Louver .....	2
Included Parts.....	2
Field Supplied Parts .....	3
Installation .....	3
Drain Pan.....	4
Installation .....	4



## WARNING

Only personnel that have been trained to install, adjust, service or repair(hereinafter, "service") the equipment specified in this manual should service the equipment. The manufacturer will not be responsible for any injury or property damage arising from improper service or service procedures. If you service this unit, you assume responsibility for any injury or property damage which may result. In addition, in jurisdictions that require one or more licenses to service the equipment specified in this manual, only licensed personnel should service the equipment. Improper installation, adjustment, servicing or repair of the equipment specified in this manual, or attempting to install, adjust, service or repair the equipment specified in this manual without proper training may result in product damage, property damage, personal injury or death.

IO-919  
07/2020

**Amana** is a registered trademark of Maytag Corporation or its related companies and is used under license to Goodman Company, L.P., Houston, TX, USA. All rights reserved.

5151 San Felipe, Suite 500 • Houston, TX 77056 • [www.amana-ptac.com](http://www.amana-ptac.com)  
© 2020 Goodman Company, L.P.



## Exterior Wall Adapter and Louver

For use with VTAC units only.

**NOTE:** The following installation instructions apply to VTAC units only. Refer to Chasis Installation / Operation Manual for additional information.

### Included Parts

PART	QNTY
Outside Assembly (Part A)	1 ea.
Inside Assembly (Part B)	1 ea.

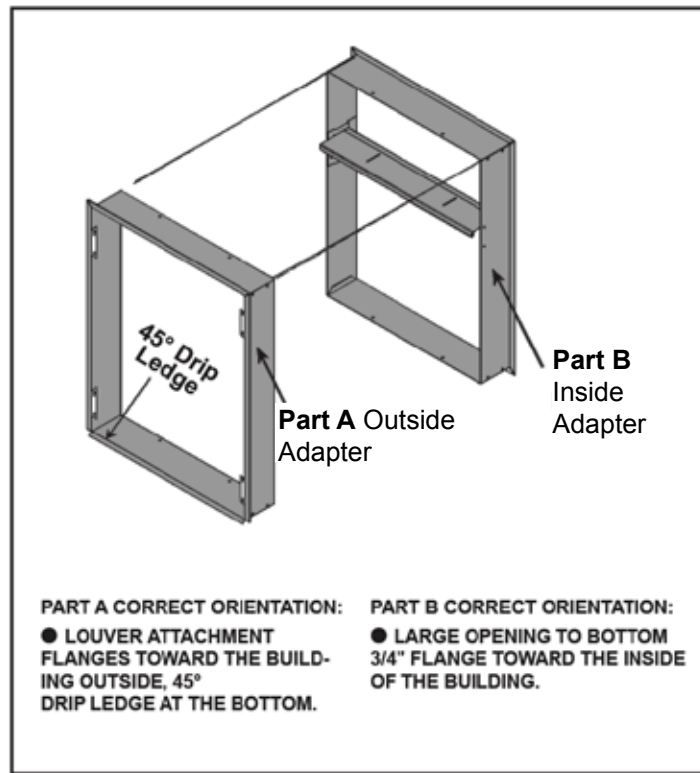

Figure 1

### Field Supplied Parts

ITEM
Sealant
Flashing
Header Materials / Wall Studs
Shims
1" -3" Screws to attach the Adapter assembly to the wall studs

Caulk, Attachment screws and Flashing are field supplied. Silicone caulk is recommended.

AVEWA05-08A adjusts for walls 5.5 - 8.0" thick.

AVEWA08-14A adjusts for walls 8 - 14.0" thick.

Both installations are similar.

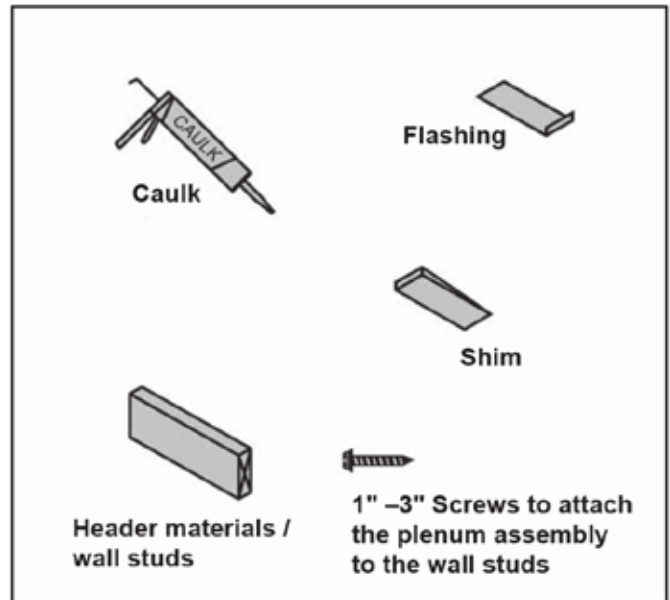

Figure 2

### Installation

1. Measure and frame out the outside Exterior Wall Adapter.

The adapter cut out dimensions are 24 5/8" wide x 30 7/8" high. The bottom of the rough in opening must be 3/4" from the surface the unit will sit on.

Measure your outside wall as shown in the illustration. Cut, frame, and square rough opening. The Exterior Wall Adapter has a 3/4" break all the way around to cover the rough cut opening or required shim.

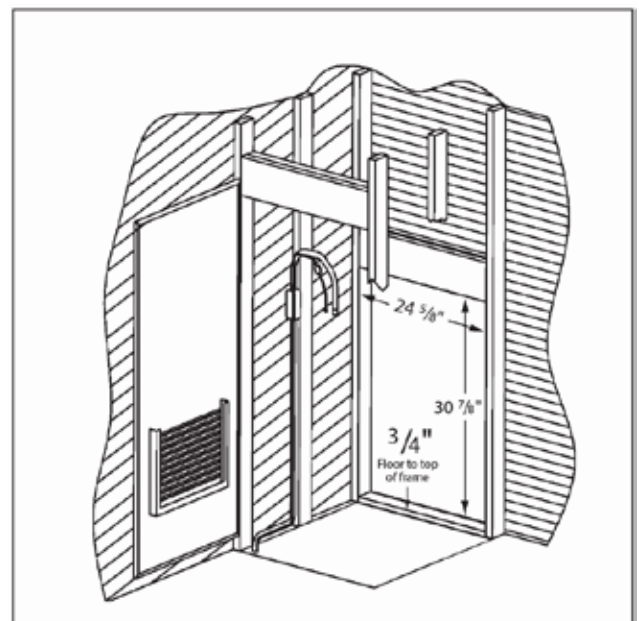

Figure 3

The Adapter cut out dimensions are 24 5/8" wide x 30 7/8" high. The bottom of the rough in opening must be 3/4" from the surface the unit will sit on.

Measure your outside wall as shown in the illustration. Cut, frame, and square rough opening. The Exterior Wall Adapter has a 3/4" break all the way around to cover the rough cut opening or required shim.

3. Adapter installation.

**NOTE:** Proper header and wall penetration must conform to all national and local building codes.

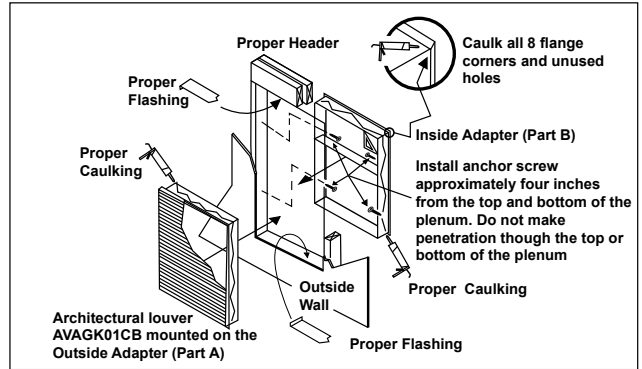

**Figure 6**

After the rough cut opening is prepared, you are ready to assemble the two Exterior Wall Adapter parts. Before caulking and permanent attachment, dry fit the outside Adapter into the rough opening and check for fit and level. Caulk (silicone recommended) the parts well and insert them into the wall as shown.

A) Apply caulk and insert Outside Part A into the hole.

B) Apply caulk and insert Inside Part B into Part A. Be sure that Part A does not back out of the wall hole.

**IMPORTANT:** The Exterior Wall Adapter is not designed to carry structural loads. A proper header opening must be built into the rough opening. The Adapter requires flashing, shim and caulk for a weather-resistant installation. It is the responsibility of the contractor to properly install the Adapter and meet building code requirements.

2. Install Architectural Louver on the Outside Adapter.

**NOTE:** The AVAGK01CB Architectural Louver is best installed onto the Outside Adapter (Part A) **PRIOR** to the Exterior Wall Adapter installation. The louver installation is easier at this point, and it will help keep the Exterior Wall Adapter square during installation.

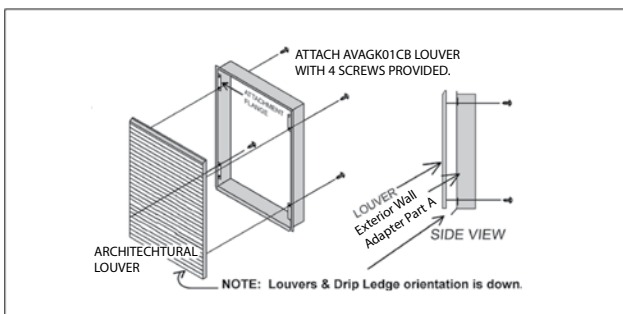

**Figure 5**

#### 4. Adjust the Divider

Loosen the two screws located on the top side of the divider. Slide the top part of the divider toward the outside until the sealing strip makes contact with the outdoor louver. Tighten the divider screws to complete the adjustment.

**NOTE:** Let the caulk cure completely before installing the chassis. This completes the Adapter installation.

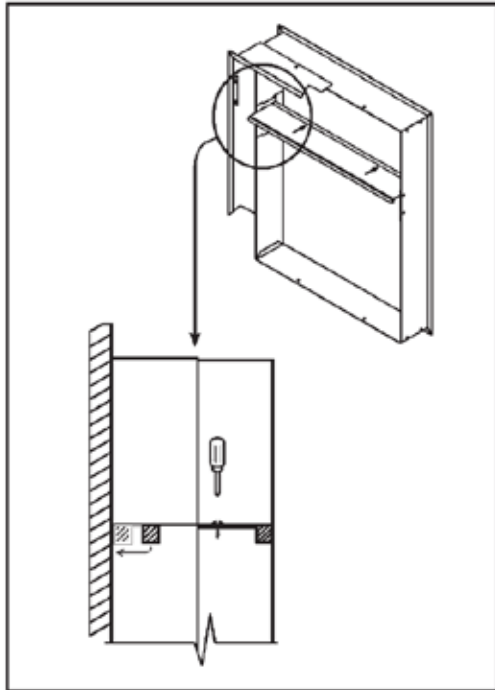

Figure 7

#### Condensate Disposal Preparation for 9000 / 12000 Models ONLY

**IMPORTANT:** This step must be performed to ensure that the chassis installs and seals properly in the Exterior Wall Adapter.

If provisions for condensate disposal are made prior to chassis installation and the drain is to be located beneath the platform for the unit, use the accompanying drawing as a guide for cutout locations. Only one drain per unit is required.

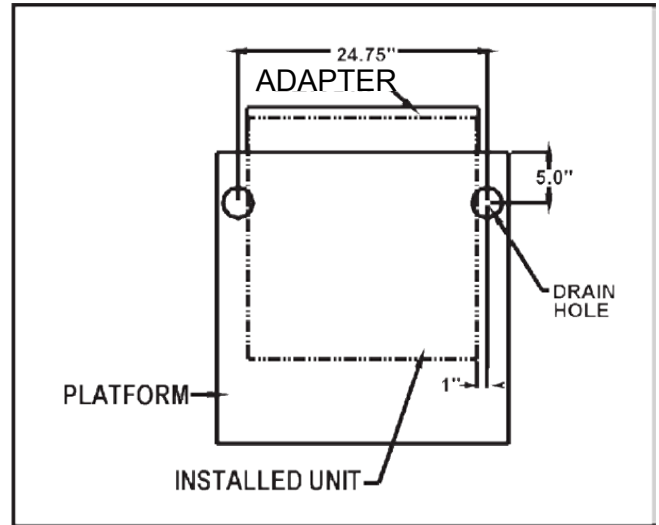

Figure 8

#### Drain Pan Installation

For use with VTAC units only.

**NOTE:** This drain pan must be installed with all AVH18 and AVH24 units.

##### 1. Cut Opening in Gasket

Remove an 8" portion of the weather seal gasket from the bottom right surface of the Adapter.

- Cut the gasket in the lower right corner of the Adapter.
- Make a second cut 8" from the right corner. The gasket should peel away from the Adapter leaving a clean mounting surface. (See Figure 1)

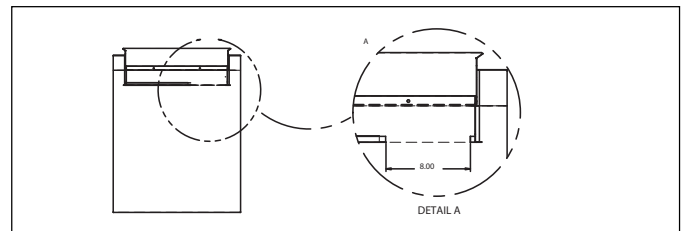

Figure 9

2. Seal and Set Pan

Prior to placing the drain pan into the opening run a 1/4" bead of sealant the entire width of the removed gasket. The pan should be placed against the right edge of the plenum (See Detail A) and the secondary overflow lip inserted into the plenum NO DEEPER THAN 1.5 INCHES to prevent water leaks (See Detail B).

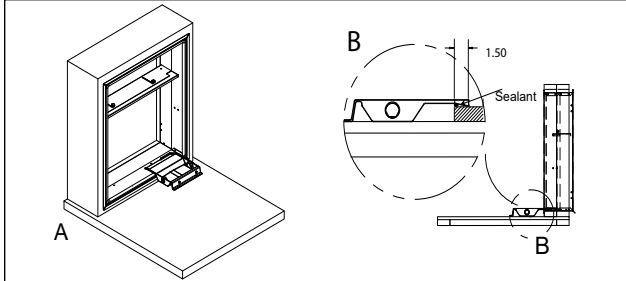

Figure 10

3. Install Drain Pan

Attach the drain pan to the closet floor with the appropriate field supplied hardware.

**Important:** To prevent water leaks use only the factory supplied mounting holes. NEVER make penetrations in the drain pan itself.

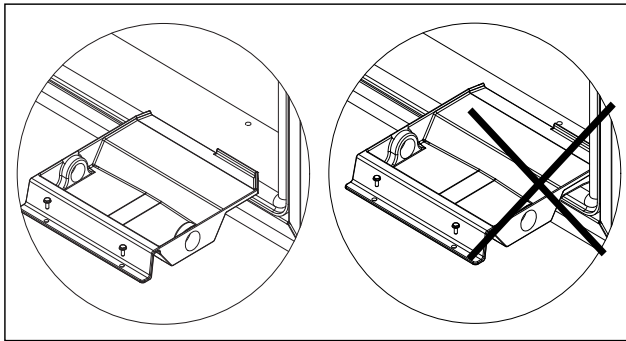

Figure 11

4. Install Drain Plug

The drain pan comes with both left and right-hand drain connections locations. Determine which of the two connections will be used to drain the condensate. Then, with the factory supplied drain plug, plug the unused opening.

**Important:** Proper sealant must be applied to the connection to prevent leak.

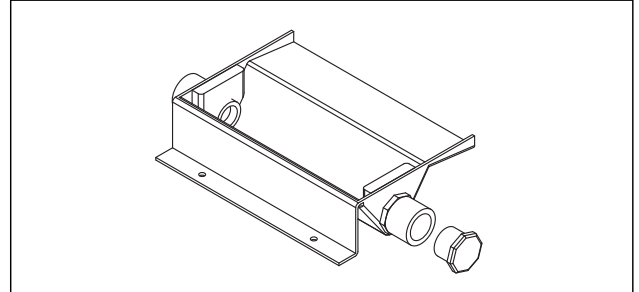

Figure 12

5. Install Drain Line

Condensate line routing options are shown below.  
Choose the one that best suits your installation.

**Important:** Never run the condensate line as shown in Option 4 below, as the drain line will come into contact with the factory-installed isolators beneath the unit.

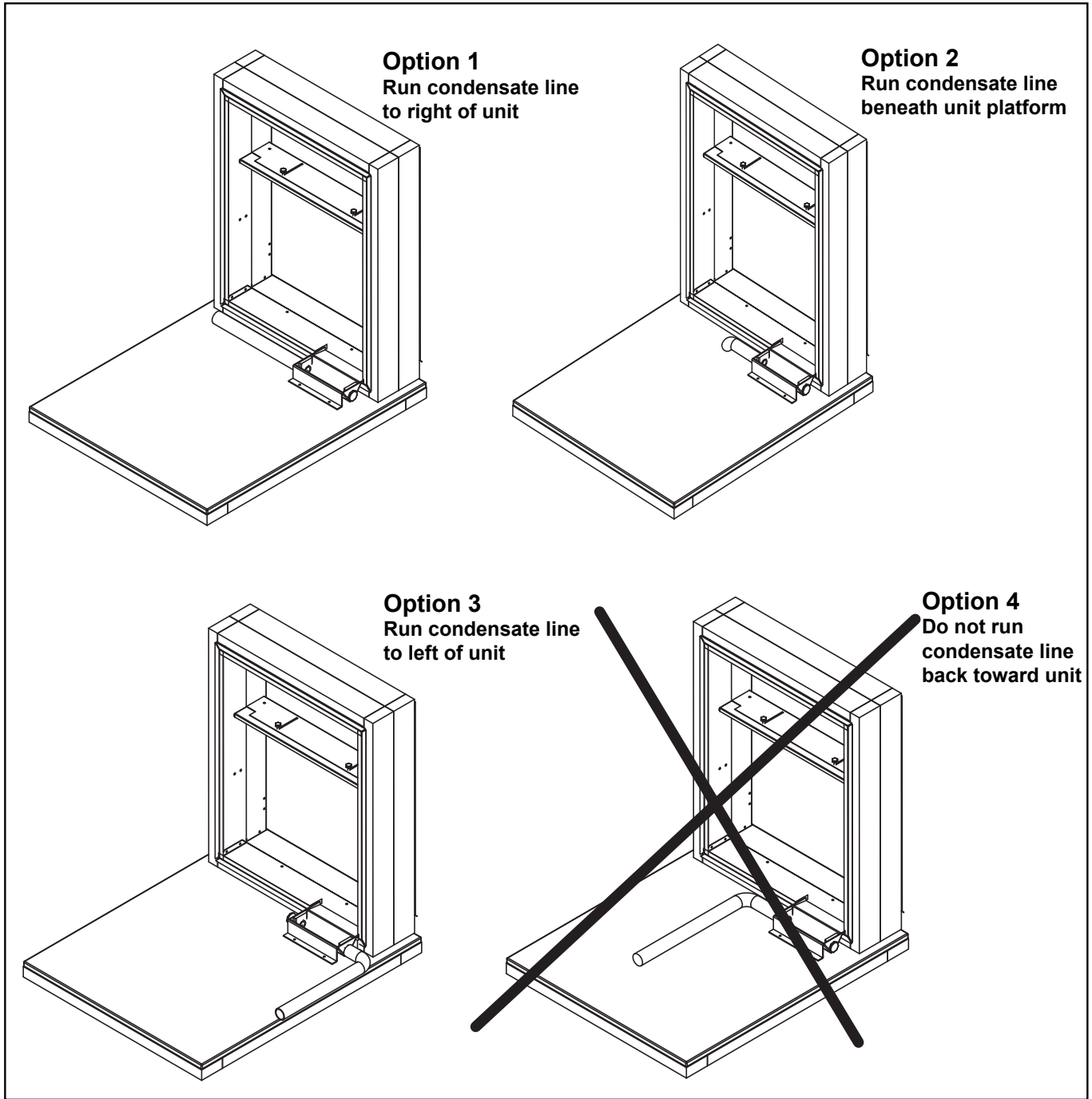

Figure 13

**THIS PAGE INTENTIONALLY LEFT BLANK**

**CUSTOMER FEEDBACK**

We are very interested in all product comments.

Please fill out the feedback form on one of the following links:

Amana® Brand Products: (<http://www.amana-hac.com/about-us/contact-us>).

You can also scan the QR code on the right for the product brand you purchased to be directed to the feedback page.



AMANA® BRAND

**Amana** is a registered trademark of Maytag Corporation or its related companies and is used under license to Goodman Company, L.P., Houston, TX, USA. All rights reserved.

5151 San Felipe, Suite 500 • Houston, TX 77056 • [www.amana-ptac.com](http://www.amana-ptac.com)  
© 2020 Goodman Company, L.P.

# DRAIN PAN FOR VTAC INSTALLATION INSTRUCTIONS

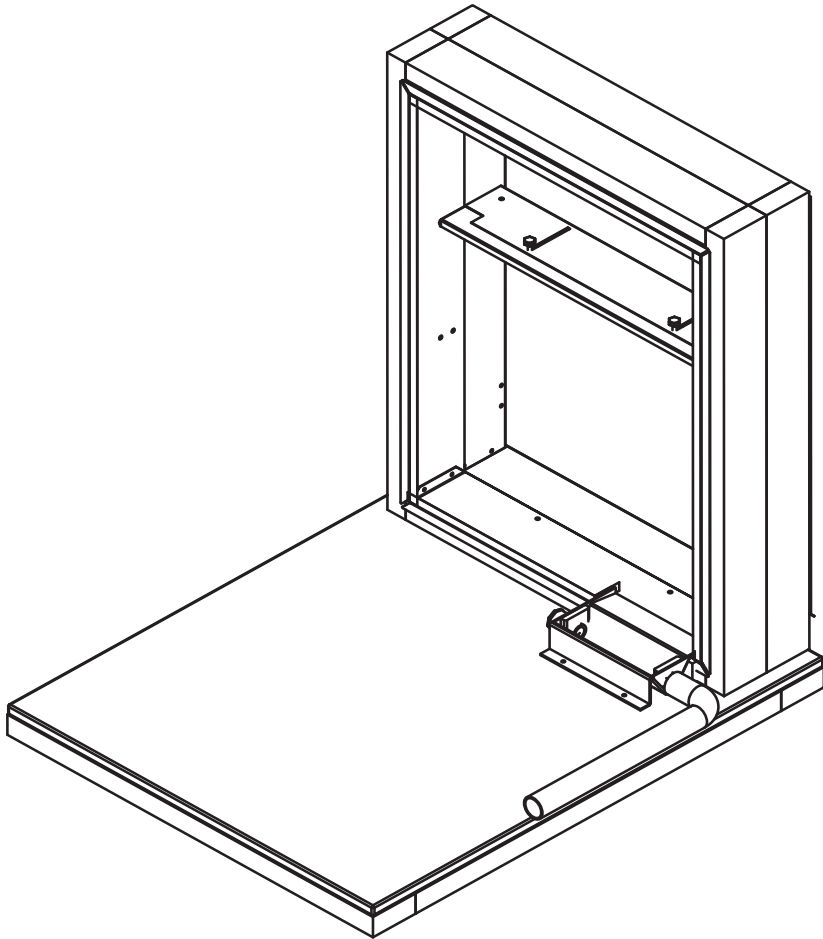

## Table of Contents

Drain Pan Installation .....	2
Cut Opening in Gasket .....	2
Seal and Set Pan.....	2
Install Drain Pan .....	2
Install Drain Plug .....	2
Install Drain Line.....	3



## WARNING

Only personnel that have been trained to install, adjust, service or repair(hereinafter, "service") the equipment specified in this manual should service the equipment. The manufacturer will not be responsible for any injury or property damage arising from improper service or service procedures. If you service this unit, you assume responsibility for any injury or property damage which may result. In addition, in jurisdictions that require one or more licenses to service the equipment specified in this manual, only licensed personnel should service the equipment. Improper installation, adjustment, servicing or repair of the equipment specified in this manual, or attempting to install, adjust, service or repair the equipment specified in this manual without proper training may result in product damage, property damage, personal injury or death.

IO-918  
07/2020

**Amana** is a registered trademark of Maytag Corporation or its related companies and is used under license to Goodman Company, L.P., Houston, TX, USA. All rights reserved.

5151 San Felipe, Suite 500 • Houston, TX 77056 • [www.amana-ptac.com](http://www.amana-ptac.com)  
© 2020 Goodman Company, L.P.



## DRAIN PAN INSTALLATION

**NOTE:** This drain pan must be installed with all and AVH18-AVH24 "H" series units (Produced after September 2019).

### Cut Opening in Gasket

Remove an 8 1/8" portion of the weather seal gasket from the bottom right surface of the plenum.

- Cut the gasket in the lower right corner of the plenum.
- Make a second cut 8 1/8" from the right corner. The gasket should peel away from the plenum leaving a clean mounting surface (See Figure 1).

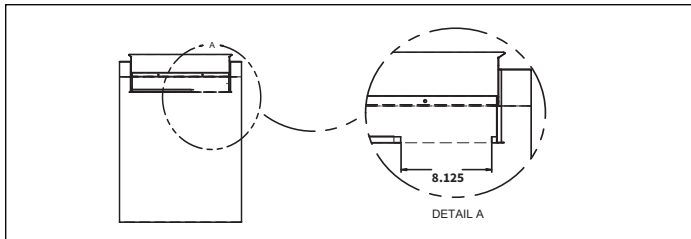

Figure 1

### Seal and Set Pan

Prior to placing the drain pan into the opening run a 1/4" bead of sealant the entire width of the removed gasket. The pan should be placed against the right edge of the plenum (See Detail A) and the secondary overflow lip inserted into the plenum NO DEEPER THAN 1.5 INCHES to prevent water leaks (See Detail B).

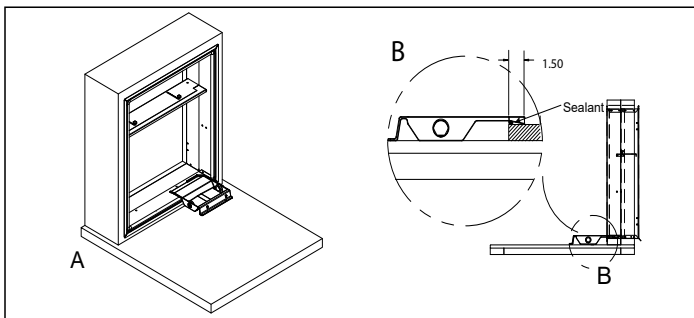

Figure 2

### Install Drain Pan

Attach the drain pan to the closet floor with the appropriate field supplied hardware.

**Important:** To prevent water leaks use only the factory supplied mounting holes. NEVER make penetrations in the drain pan itself.

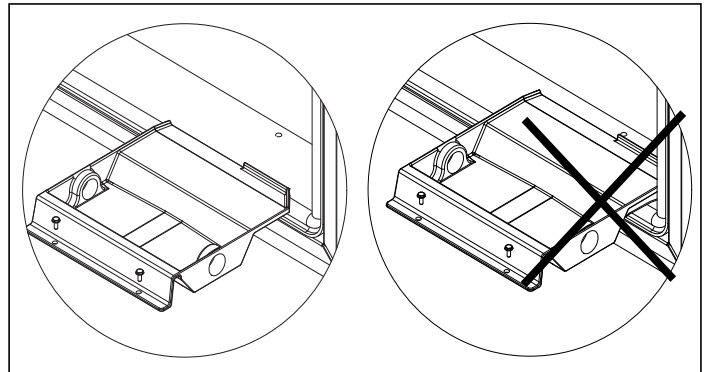

Figure 3

### Install Drain Plug

The drain pan comes with both left and right-hand drain connections locations. Determine which of the two connections will be used to drain the condensate. Then, with the factory supplied drain plug, plug the unused opening.

**Important:** Proper sealant must be applied to the connection to prevent leaks.

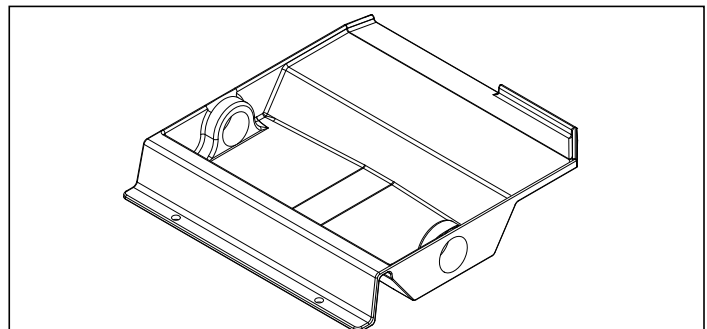

Figure 4

### Install Drain Line

Condensate line routing options are shown below. Choose the one that best suits your installation.

**Important:** Never run the condensate line as shown in Option 4 below, as the drain line will come into contact with the factory-installed isolators beneath the unit.

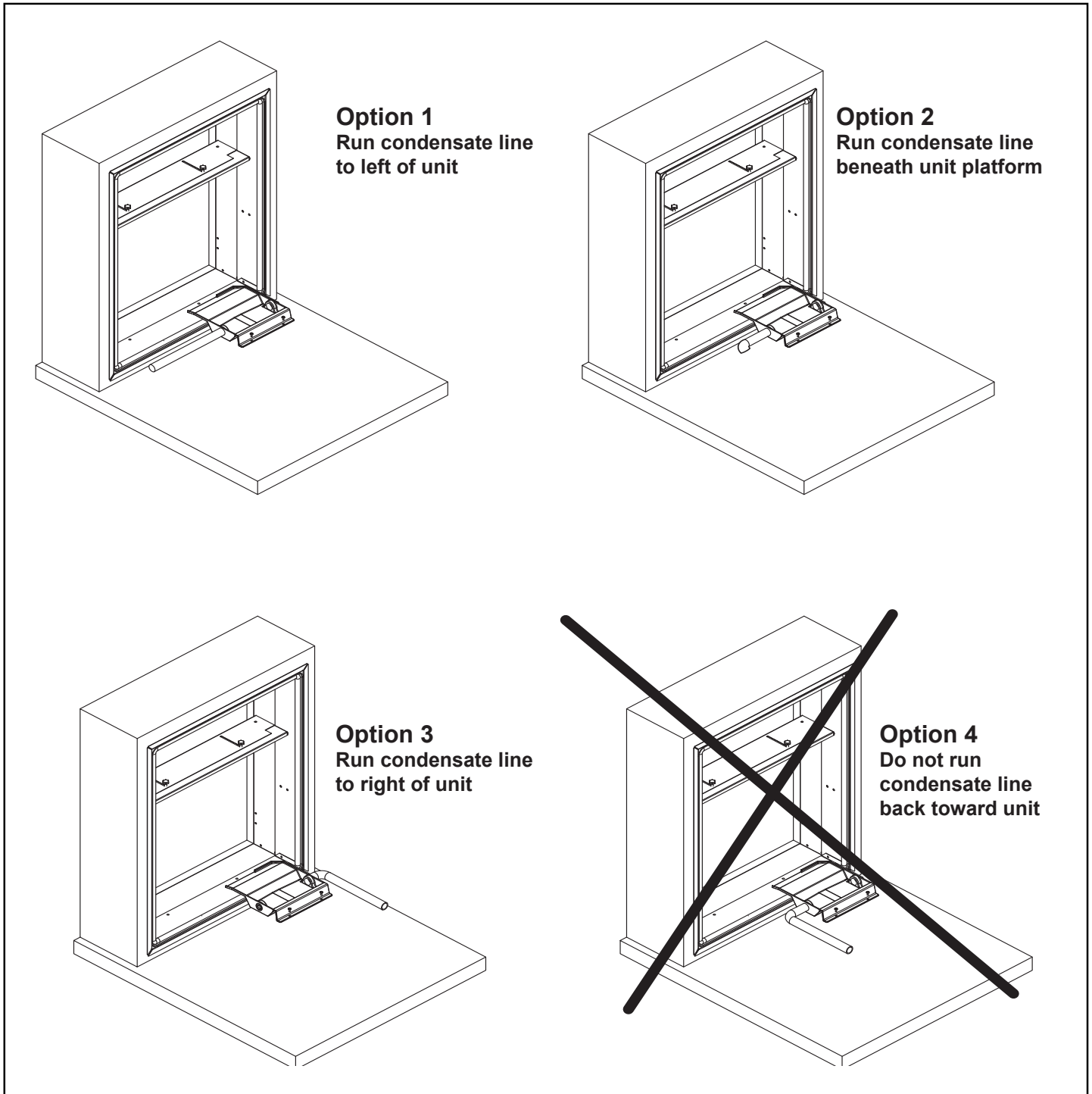

Figure 5

**CUSTOMER FEEDBACK**

We are very interested in all product comments.

Please fill out the feedback form on one of the following links:

Amana® Brand Products: (<http://www.amana-hac.com/about-us/contact-us>).

You can also scan the QR code on the right for the product brand you purchased to be directed to the feedback page.



AMANA® BRAND

**Amana** is a registered trademark of Maytag Corporation or its related companies and is used under license to Goodman Company, L.P., Houston, TX, USA. All rights reserved.

5151 San Felipe, Suite 500 • Houston, TX 77056 • [www.amana-ptac.com](http://www.amana-ptac.com)  
© 2020 Goodman Company, L.P.

# VTAC

## Single Package Vertical Air Conditioning System

### AVH 9,000-24,000 Btu/hr Installation Instructions & Owner's Manual

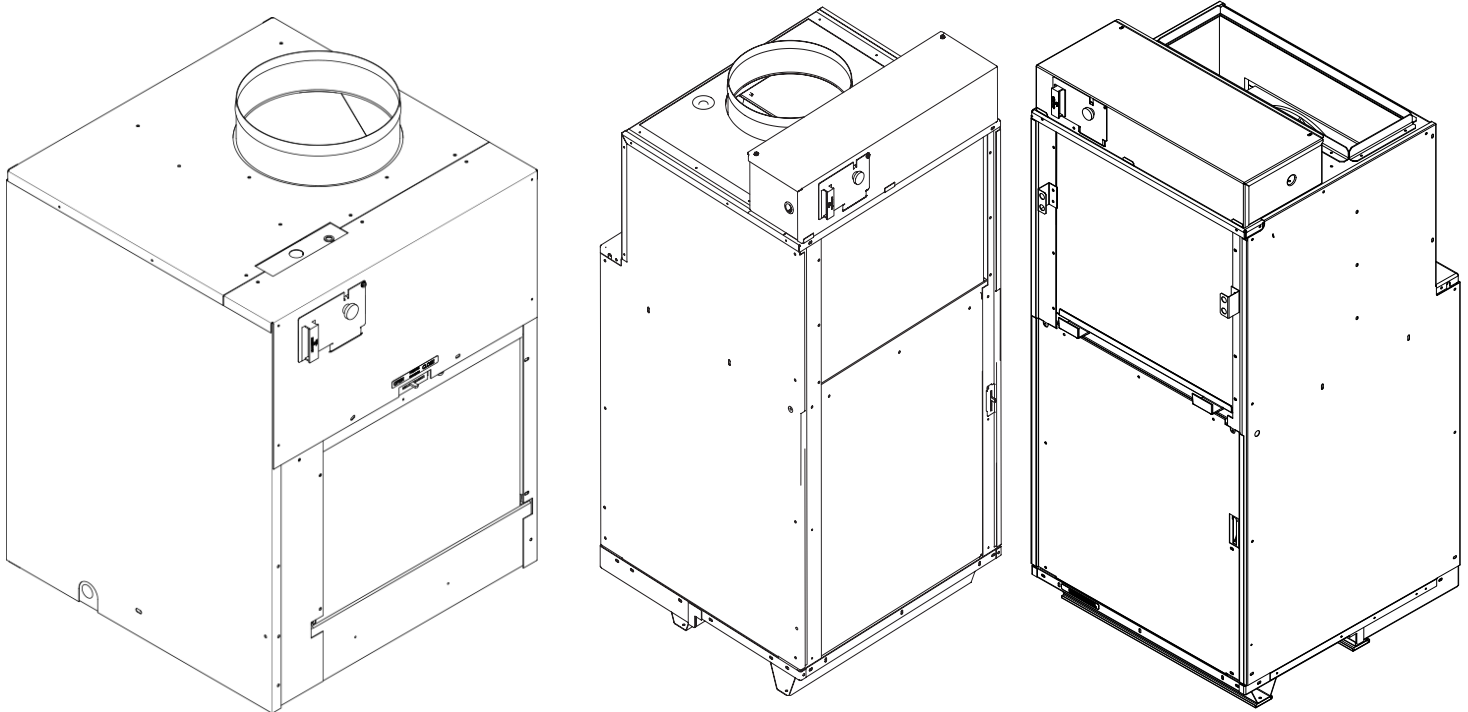

#### ATTENTION INSTALLING PERSONNEL

As a professional installer you have an obligation to know the product better than the customer. This includes all safety precautions and related items.

Prior to actual installation, thoroughly familiarize yourself with this Instruction Manual. Pay special attention to all safety warnings.

Often during installation or repair it is possible to place yourself in a position which is more hazardous than when the unit is in operation.



#### WARNING

Only personnel that have been trained to install, adjust, service or repair (hereinafter, "service") the equipment specified in this manual should service the equipment. The manufacturer will not be responsible for any injury or property damage arising from improper service or service procedures. If you service this unit, you assume responsibility for any injury or property damage which may result. In addition, in jurisdictions that require one or more licenses to service the equipment specified in this manual, only licensed personnel should service the equipment. Improper installation, adjustment, servicing or repair of the equipment specified in this manual, or attempting to install, adjust, service or repair the equipment specified in this manual without proper training may result in product damage, property damage, personal injury or death.

#### PROP 65 WARNING FOR CALIFORNIA CONSUMERS



#### WARNING

Cancer and Reproductive Harm -  
[www.P65Warnings.ca.gov](http://www.P65Warnings.ca.gov)

0140M00513-A

IO-914  
07/2020

**Amana** is a registered trademark of Maytag Corporation or its related companies and is used under license to Goodman Company, L.P., Houston, TX, USA. All rights reserved.

5151 San Felipe, Suite 500 • Houston, TX 77056 •

© 2014 - 2015, 2017 - 2020 Goodman Company, L.P.



# Contents

Electrical Data .....2  
 Supply Air Flow Data.....3  
 Control.....3  
 VTAC Required Minimum Clearances.....3  
 Installation Overview and Dimensional Data .....4  
 Closet View.....4  
 Exterior Wall Adapter Installation.....5  
 Louver Installation.....6  
 Final Wall Adapter and Architectural Louver Installation.....7  
 Primary Drain Connection and Location.....8  
 Drain Pan Installation AVH18 & AVH24.....8  
 Indoor Return Air Grille and Ductwork Installation.....12  
 Ductwork.....12  
 Chassis Installation.....12  
 Remote Thermostat and Low Voltage Control  
 Connection.....13  
 Final Installation Checklist.....14  
 Chassis Operation.....14  
 Chassis Final Connections.....14  
 Service & Warranty.....14  
 Routine Maintenance.....15  
 Warranty.....15  
 Electronic Control Error Code Diagnostics and  
 Test Mode.....15  
 ERROR CODES AND ALARM STATUS.....16  
 Obtaining Service.....20

## Important Note to the Owner

This manual is to be used by qualified, professionally trained HVAC technicians only. Goodman does not assume any responsibility for property damage or personal injury for improper service procedures or services performed by an unqualified person.

### IMPORTANT NOTES:

Your warranty certificate is also supplied with the unit. Read the warranty carefully and note what is covered. Keep the warranty certificate in a safe place, so you can find it, if necessary.

Before using this manual, check the serial plate for proper model identification.

**THE INSTALLATION AND SERVICING OF THIS EQUIPMENT MUST BE PERFORMED BY QUALIFIED, EXPERIENCED TECHNICIANS ONLY.**

Due to policy of continual product improvement, the right is reserved to change specifications and design without notice.

Remember, it is your responsibility to install the product safely and to know it well enough to be able to instruct a customer in its safe use.



Safety is a matter of common sense...a matter of thinking before acting. Most dealers have a list of specific good safety practices...follow them.

The precautions listed in this Installation Manual are intended as supplemental to existing practices. However, if there is a direct conflict between existing practices and the content of this manual, the precautions listed here take precedence.

### Important Note to the Servicer

Read this manual and familiarize yourself with the specific items which must be adhered to before attempting to service this unit. The precautions listed in this Installation Manual are intended as supplemental to existing practices. However, if there is a direct conflict between existing practices and the content of this manual, the precautions listed here take precedence.

 **RECOGNIZE THIS SYMBOL AS A SAFETY PRECAUTION.**

 <b>WARNING</b>
<p><b>HIGH VOLTAGE</b>                  DISCONNECT ALL POWER BEFORE SERVICING OR INSTALLING THIS UNIT. MULTIPLE POWER SOURCES MAY BE PRESENT. FAILURE TO DO SO MAY CAUSE PROPERTY DAMAGE, PERSONAL INJURY OR DEATH.</p> 

## Electrical Data

Electrical Requirements	
Wire Size	Use <b>ONLY</b> wire size recommended for single outlet branch circuit.
Fuse/Circuit Breaker	Use <b>ONLY</b> type and size fuse or HACR circuit breaker indicated on unit's rating guide. Proper over current protection to the units is the responsibility of the owner.
Grounding	Unit <b>MUST</b> be grounded from branch circuit to unit, or through separate ground wire provided on permanently connected units. Ensure that branch circuit or general purpose outlet is grounded.
Wire Sizing	Use recommended wire size given in tables and install a single branch circuit. All wiring must comply with local and national codes. NOTE: Use copper conductors only.

## Electrical Rating Table



NOTE: Use copper conductors **ONLY**. Wire sizes are per NEC.

Recommended Branch Circuit Sizes*	
Nameplate Maximum Circuit Breaker Size	AWG Wiring Size**
15A	14
20A	12
30A	10

AWG - American Wire Gauge

\* Single circuit from main box.

\*\* Based on 100' or less of copper, single insulated conductor at 60° C

 <b>WARNING</b>	
<p><b>HIGH VOLTAGE</b> DISCONNECT ALL POWER BEFORE SERVICING OR INSTALLING THIS UNIT. MULTIPLE POWER SOURCES MAY BE PRESENT. FAILURE TO DO SO MAY CAUSE PROPERTY DAMAGE, PERSONAL INJURY OR DEATH. DO NOT SERVICE THIS UNIT WITHOUT FIRST SHUTTING OFF POWER TO THE UNIT FROM THE CIRCUIT BREAKER AND/OR REMOVING THE UNIT CORD SET PLUG FROM THE WALL OUTLET.</p>	

**NOTE:** All 230/208 chassis must be hard wired with a properly sized breaker. See unit nameplate for specific electrical requirements. Use HACR type breakers to avoid nuisance trips. All field wiring must be done in accordance with NEC and local codes. It is the installer's responsibility to ensure that the electrical codes are met.

## Supply Air Flow Data Indoor CFM & External Static Pressure

Fan Speed	Model					
	AVH09/AVH12		AVH18		AVH24	
Low	High	Low	High	Low	High	High
ESP (")	SCFM					
0.0"	470	520	730	800	755	805
0.05"	460	510	670	735	700	750
0.10"	430	490	630	675	660	700
0.15"	410	470	595	640	615	665
0.20"	360	440	550	600	575	625
0.25"	310	400	505	550	525	580
0.30"	260	350	455	500	485	540
0.35"	--	--	400	445	450	500
0.40"	--	--	345	400	415	465

Indoor air flow may be determined by measuring the external static pressure (ESP) of the duct system using an inclined manometer or magnahelic gauge and consulting the above chart to derive actual air flow. Under no circumstances should the small chassis VTAC equipment be operated at an external static pressure in excess of .3" W.C. Operation of the VTAC under these conditions will result in inadequate air flow, leading to poor performance and/or premature component failure.

### Control

For LOW speed only operation, connect the fan output terminal from the thermostat to the GL terminal of the electronic control.

For HIGH speed only operation, connect the fan output terminal from the thermostat to the GH terminal of the electronic control.

For thermostats with two-speed capability, connect the LOW speed output to the GL terminal and the HIGH speed output to the GH terminal.

### VTAC Required Minimum Clearances

#### Building Exterior Unit Opening Requirements

VTAC units must be installed on an outside wall. Confined spaces and/or covered areas should be avoided. Units must be installed no closer than 12" apart when two units are side by side. If three or more units are to operate next to one another, maintain a minimum of 60" between units or pairs of units (Figure B). If more than two units are sharing a floor with adjacent, outset units, a minimum distance of 64" must be kept between units (Figure C). Also, a vertical clearance of 60" must be maintained (Figure A) between units. Units installed on the bottom floor must be mounted at least 6" off of the ground.

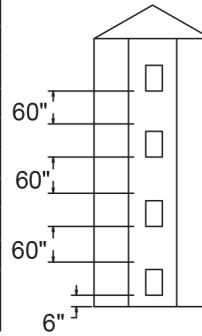
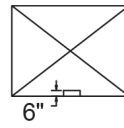

Figure A

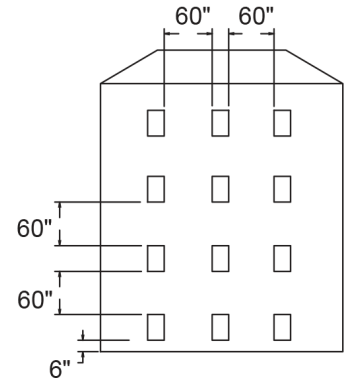

Figure B

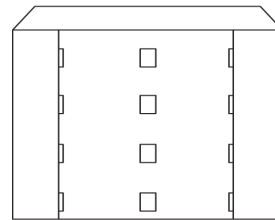
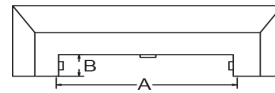

Figure C

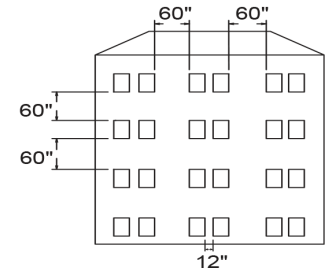
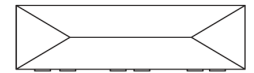

Figure D

### Grill Clearance Requirements

Where obstructions are present use the following guidelines for proper spacing from the VTAC exterior louvered grill. Amana recommends that ALL obstructions are a minimum of 72" from the exhaust.

For minor obstruction(s) such as lamp poles or small shrubbery, a clearance of 24" from the outdoor louver must be maintained.

For major obstructions such as a solid fence, wall, or other heat rejecting devices like a condensing unit, a minimum distance of 72" must be kept.

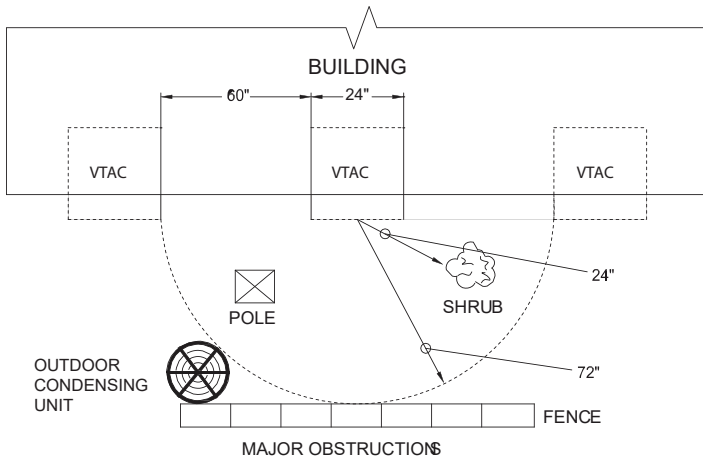

**NOTE:** The example pictured above is for reference only and does not represent all possible installations.

### Installation Overview and Dimensional Data

#### Dimensions

AVH09 / AVH12 Chassis Dimensions (W x D x H)	23 1/8" x 23 1/8" x 32 1/4"
AVH18 Chassis Dimensions (W x D x H)	23 1/8" x 23 1/8" x 47 15/16"
AVH24 Chassis Dimensions (W x D x H)	23 1/8" x 23 1/8" x 51 7/8"
Exterior Rough Opening (W x H)	24 5/8" x 30 7/8"
Closet Rough Opening (W x H)	27" x 55 3/4"

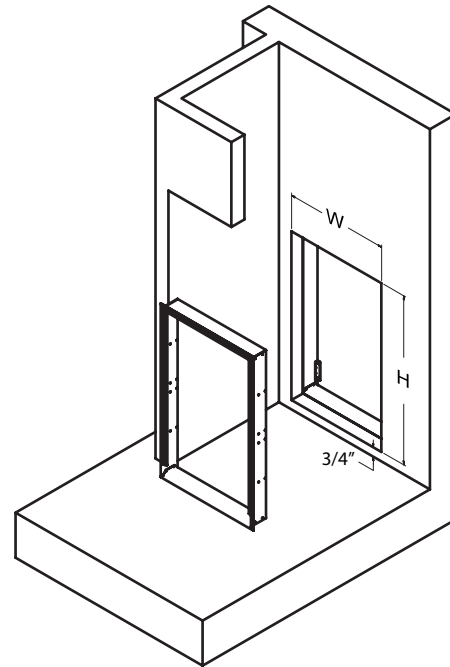

Exterior Wall Adapter Cut-Out Dimensions (W x H): 24 5/8" x 30 7/8"

**NOTE:** The distance between the rough opening and the finished floor/platform must be 3/4". If the installation will utilize an auxiliary drain pan, it may not exceed 3/4" in height.

### Closet View

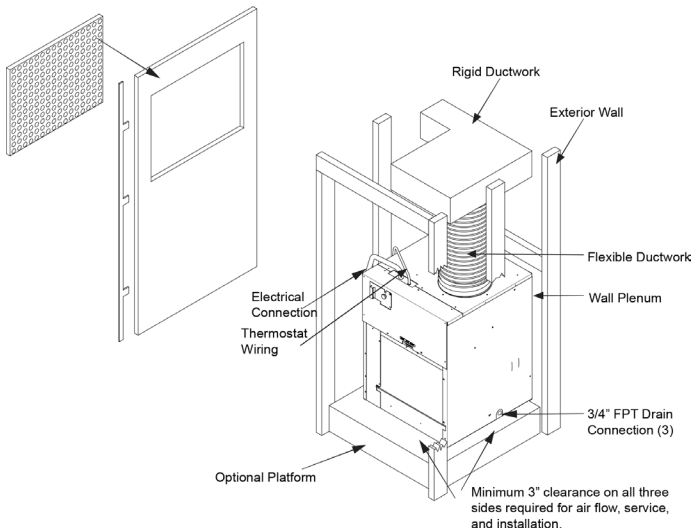

**NOTE:** It is recommended that 6" of clearance is provided on the side where the primary condensate is plumbed.

# CLOSET INSTALLATIONS

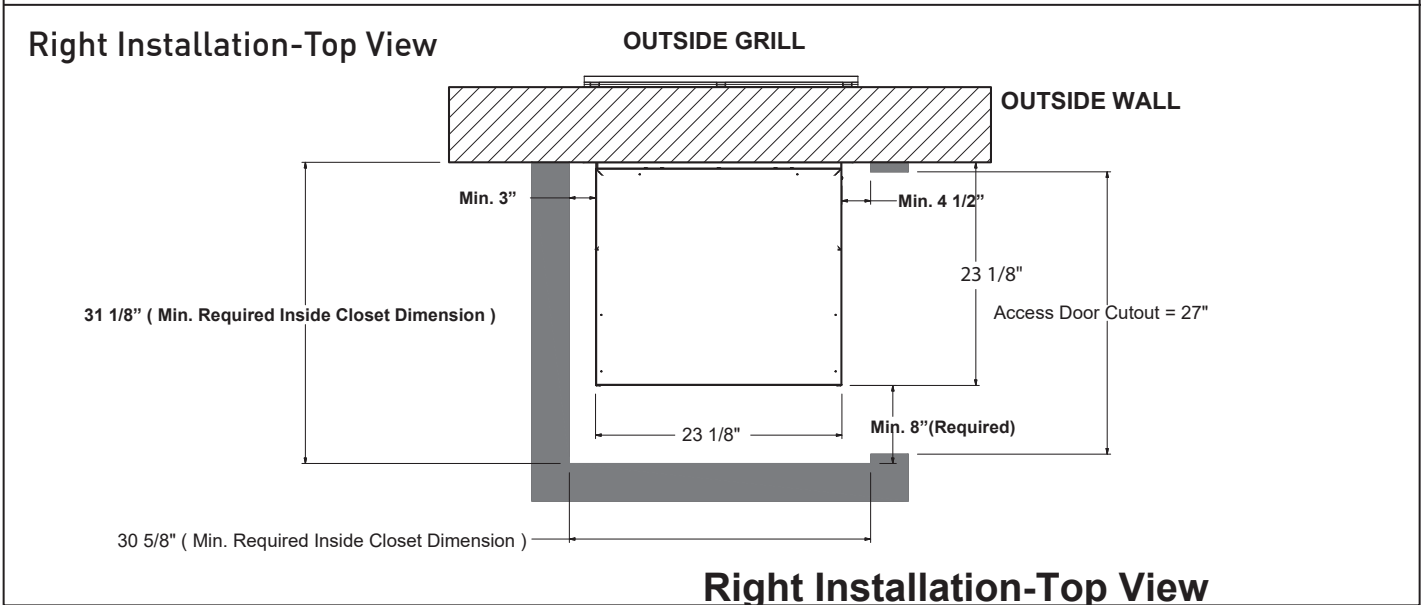
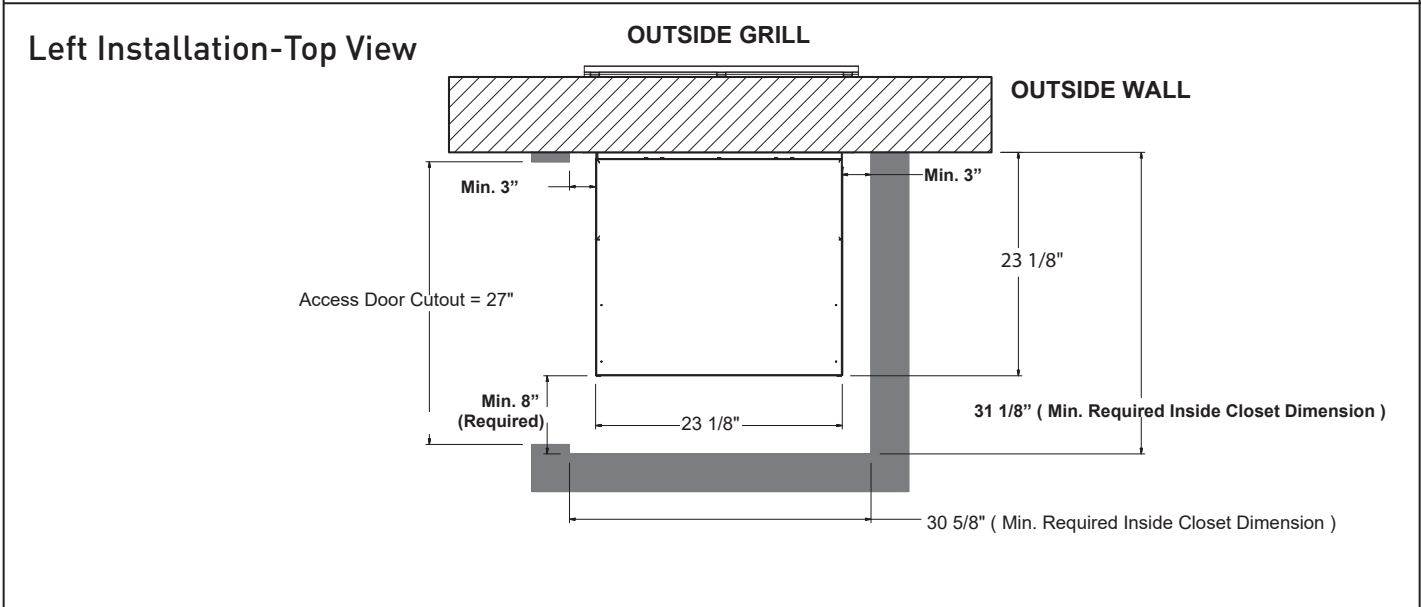
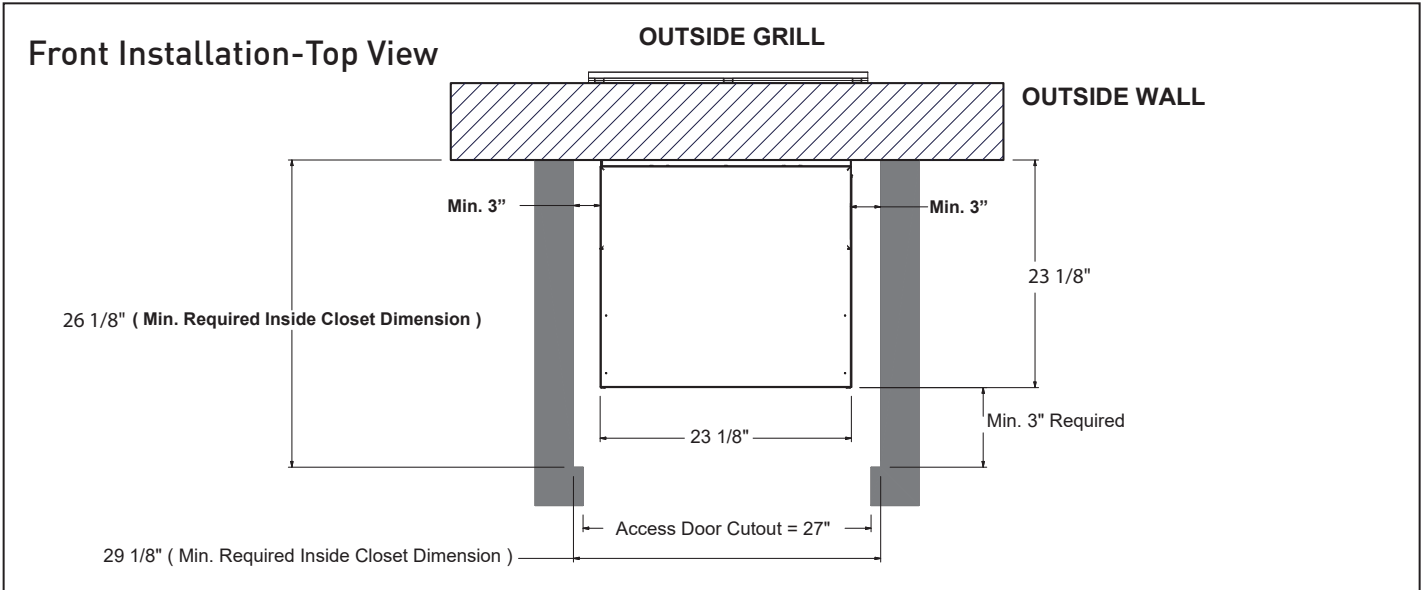

**Applicable Models**  
 AVH09xxxxxxxxx  
 AVH12xxxxxxxxx

Small Chassis Unit  
 (Unit height 32")

Filter (14" x 20")

Architectural Grille  
 AVAGK01xx

Part A  
 Outside  
 Wall Adapter

Exterior/  
 Outside Wall

Part B  
 Inside  
 Wall Adapter

Unit

Outside  
 Wall

11"

7"

10"

6"

2"

AVEWA05-08A = 5 1/2" - 8" D x 24 1/8" W x 30 3/8" H  
 AVEWA08-14A = 8" - 14" D x 24 1/8" W x 30 3/8" H

**Applicable Models**  
 AVH18xxxxxxxxx

Large Chassis Unit  
 (Unit height 47")

Filter (14" x 20")

Architectural Grille  
 AVAGK01xx

Part A  
 Outside  
 Wall Adapter

Exterior/  
 Outside Wall

Part B  
 Inside  
 Wall Adapter

Unit

control box

22  
 5/16"

8 3/8"

6 3/16"

Outside  
 Wall

10"

4 3/16"

5 5/16"

7 3/16"

AVDK18-2401B drain pan  
 required (Sold & Shipped  
 Separately)

AVEWA05-08A = 5 1/2" - 8" D x 24 1/8" W x 30 3/8" H  
 AVEWA08-14A = 8" - 14" D x 24 1/8" W x 30 3/8" H

**Applicable Models**  
 AVH24xxxxxxxxx

24k Chassis Unit  
 (Unit height 52")

Filter (18" x 20")

Architectural Grille  
 AVAGK01xx

Part A  
 Outside  
 Wall Adapter

Exterior/  
 Outside Wall

Part B  
 Inside  
 Wall Adapter

Unit

12 19/64"

1 1/2"

6 55/64"

3 55/64"

Outside  
 Wall

20 5/8"

AVDK18-2401B drain pan  
 required (Sold & Shipped  
 Separately)

AVEWA05-08A = 5 1/2" - 8" D x 24 1/8" W x 30 3/8" H  
 AVEWA08-14A = 8" - 14" D x 24 1/8" W x 30 3/8" H

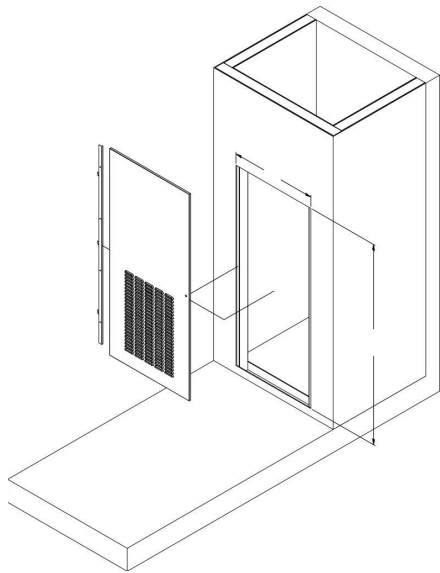

Return Air Access Door Wall Cut-Out  
Dimensions (W x H): 27" x 55 3/4"

#### Field Supplied Parts:

Sealant, attachment screws, and flashing are field supplied. Silicone sealant is recommended.

AVEWA05-08A adjust for walls up to 4" - 8" thick.

AVEWA08-14A adjust for walls up to 8" - 14" thick

All installations are similar.

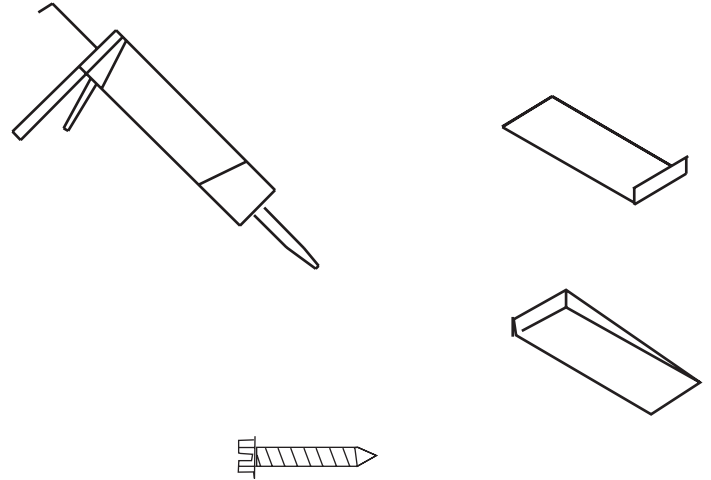

### Wall Adapter Installation

Parts included in Wall Adapter Kit:

- Outside Adapter Half (Part A)
- Inside Adapter Half (Part B)

#### Step 1 - Outside Wall Adapter Half

**NOTE: The Wall Adapter is not designed to carry any structural load. A load bearing header must be built above the rough opening.**

1. Prepare the rough opening. The rough opening should be lined with metal or wood. The Wall Adapter will warp if sealed against concrete or brick.
2. Dry fit the outside Wall Adapter half into the rough opening and check the fit and level.
3. Remove the outside Wall Adapter half, flash the rough opening to ensure proper fit and level.
4. Pre-installing the exterior louver (AVAGK01CB) as shown above is optional (See Page 6).
5. Apply sealant to the outside Wall Adapter half and insert into the rough opening to ensure a water-tight seal. Ensure that the outside Wall Adapter half is securely attached to the framed opening.

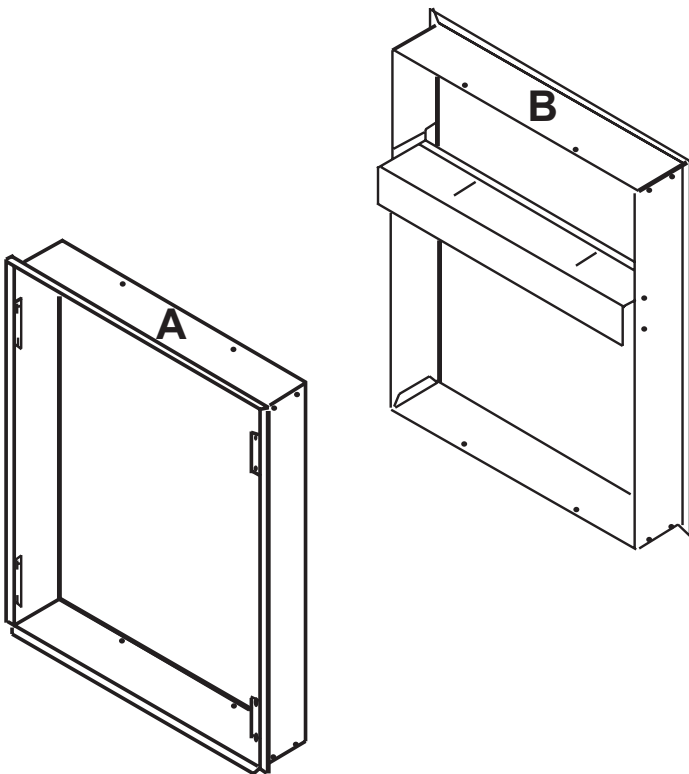

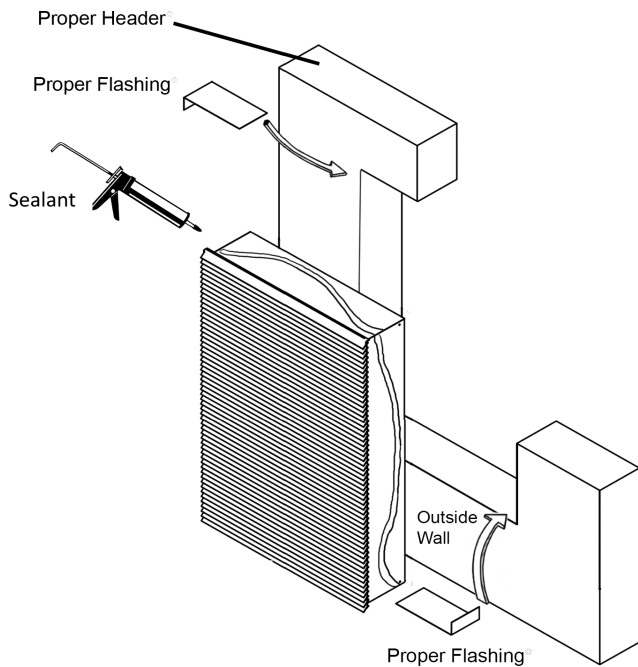

### Step 3 - Inside Wall Adapter (cont.)

**NOTE: Do not place any screws, fasteners, or penetrating holes through the top or bottom of the Wall Adapter assembly.**

1. Drill pilot holes on the interior of the inside Wall Adapter half (Part B) as show in Detail B. Pilot holes should be located approximately 4" from the top and bottom of the inside Wall Adapter half, on both the left and right sides.
2. Install fasteners through each pilot hole. Fastener must pass through both Part A and Part B. If the inside and outside Wall Adapter halves do not overlap at fastening point, be certain to drill extra holes where needed to secure both Part A and Part B to the rough opening.

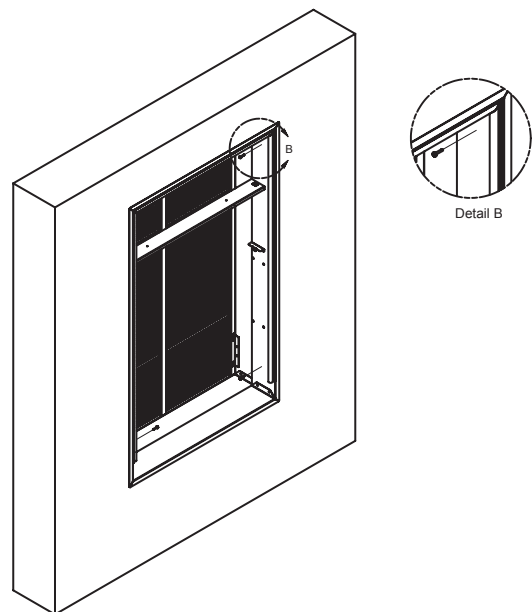

### Step 2 - Inside Wall Adapter Half

1. Apply sealant to all 4 flange corners and unused holes. See Detail A.
2. Flash the inside of the rough opening to ensure the proper fit and level.
3. Insert inside Wall Adapter half (Part B) into outside Wall Adapter half (Part A). Ensure that Part A does not back out of the rough opening.
4. Remove the inside Wall Adapter half.
5. Apply sealant to the outside Wall Adapter half and insert into the rough opening to ensure a water-tight seal.

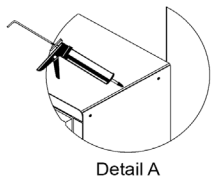

Apply Sealant to all 4 flange corners and unused holes.

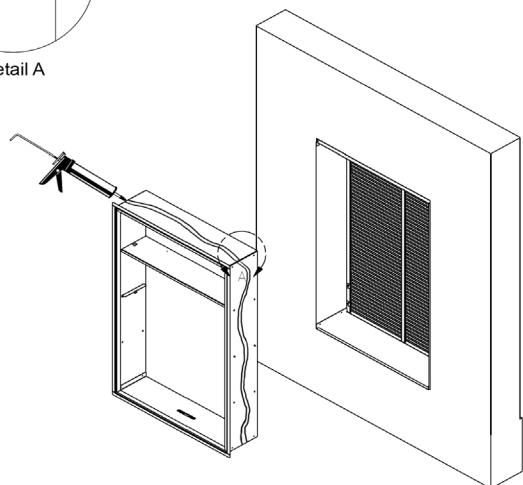

### Louver Installation

#### Installation of the louver PRIOR to Wall Adapter installation

1. Hold the louver up to the outside Wall Adapter half (Part A) and line up the louver top with the very top edge of the 3/4" flange.
2. Line up the Wall Adapter holes with the threaded holes in the louver and securely tighten fasteners.

## Final Wall Adapter and Architectural Louver Installation

**NOTE:** Ensure that the weather strip is undamaged and provides a continuous seal around the inner perimeter of the Wall Adapter.

Apply silicone grease or other non-petroleum-based lubricants to the weather strip to enhance the sealing capability of the weather strip and ease installation of the air conditioner chassis.

1. Loosen the two set screws located on the top side of the divider.
2. Slide the top part of the divider toward the outside until the sealing strip makes contact with the exterior louver.
3. Tighten the set screws to complete the adjustment.

**NOTE:** Let all flashing cure completely before installing the chassis.

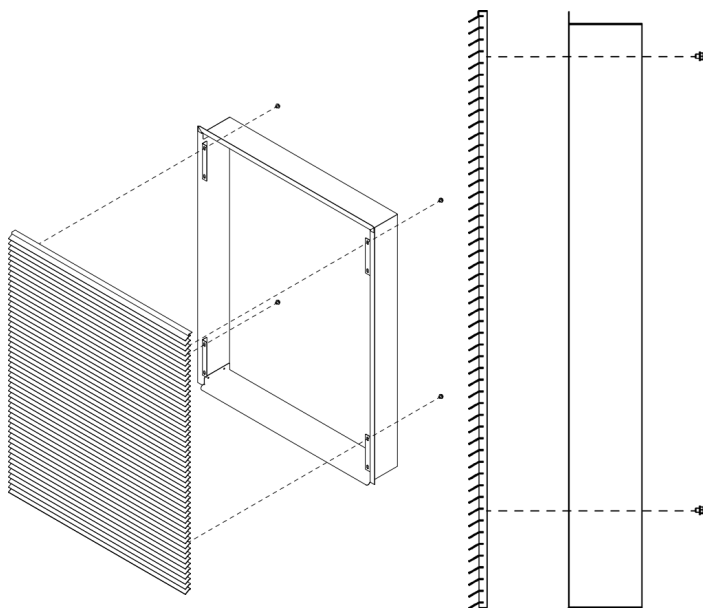

### Installation of the louver AFTER the installation of Wall Adapter on elevated floors

#### From the interior of the utility closet:

1. Tie a rope or tether to the architectural louver and the divider in the Wall Adapter to prevent it from falling if dropped.
2. Turn the louver sideways and push the louver out below the divider in the Wall Adapter.
3. Pull the louver back against the Wall Adapter and align the holes.
4. Insert and tighten all eight provided fasteners. When the louver is secured, remove the safety tether.

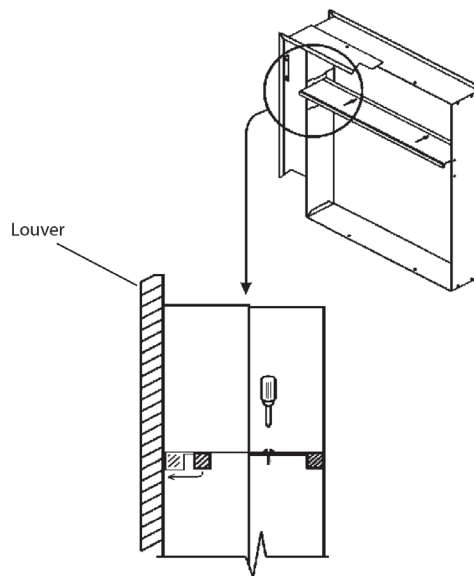
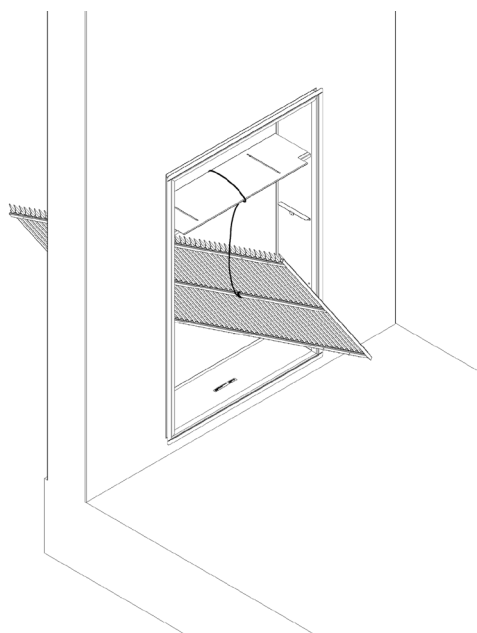

## Primary Drain Connection and Location

### For AVH09 & AVH12 Units only

**NOTE: Failure to follow the following procedures may result in serious property damage. A field supplied secondary condensate pan or P-trap may be required. Check with local codes. In case of drainage system blockage, the unit base will allow excess water to flow out of the unit through the wall adapter and the architectural louver. It is critical to ensure that the drainage path is not blocked or obstructed in any way during the installation.**

1. The supplied drain kit must be connected to one of the three (left, right or rear) 3/4" FPT connections on the unit base pan. Use of rear fitting without connection to DWV system (drain, waste, vent) may result in staining of the outside wall.
2. Insert the provided 3/4" nipple into the determined connection using field-supplied Teflon tape or pipe joint compound.
3. With the slip end of a 3/4" union, connect to the nipple with Teflon tape or pipe joint compound.
4. Hand-tighten all fittings to prevent damage to unit or fittings.
5. Install a field-supplied drain system to the slip end of the union. A trap is recommended and drain connections should be connected to building DWV system. Pitch the drain line of a 1/4" downward slope for every foot (1') of lateral horizontal run to the DWV.
6. Plug the two unused connection ports with the two provided 3/4" pipe plugs with field-supplied Teflon tape or pipe joint compound. Hand tighten to prevent damage to the unit or fittings. Do not thread metal or copper pipe fittings directly into unit.
7. Check the system for leaks.

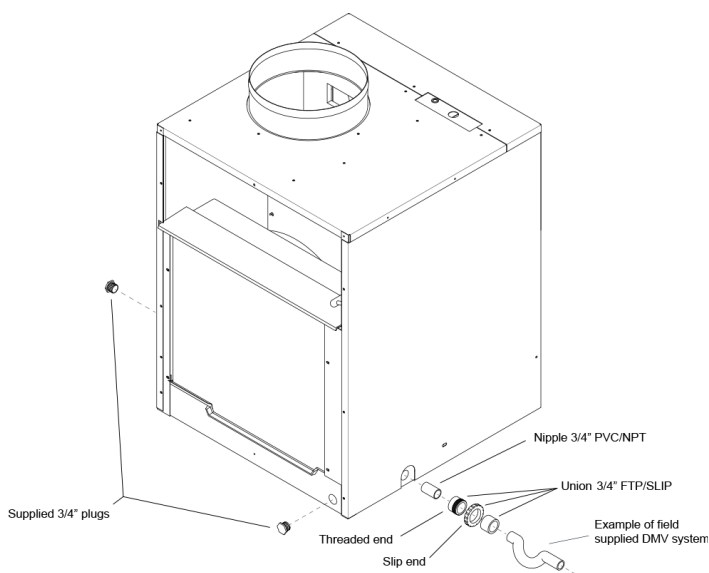

## DRAIN PAN INSTALLATION

**NOTE:** This drain pan must be installed with all and AVH18-AVH24 "H" series units (Produced after September 2019).

### Cut Opening in Gasket

Remove an 8 1/8" portion of the weather seal gasket from the bottom right surface of the plenum.

- Cut the gasket in the lower right corner of the plenum.
- Make a second cut 8 1/8" from the right corner. The gasket should peel away from the plenum leaving a clean mounting surface (See Figure 1).

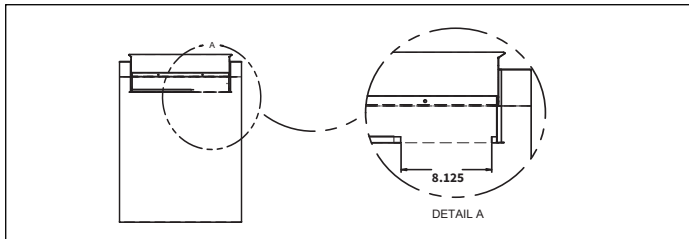

Figure 1

### Seal and Set Pan

Prior to placing the drain pan into the opening run a 1/4" bead of sealant the entire width of the removed gasket. The pan should be placed against the right edge of the plenum (See Detail A) and the secondary overflow lip inserted into the plenum NO DEEPER THAN 1.5 INCHES to prevent water leaks (See Detail B).

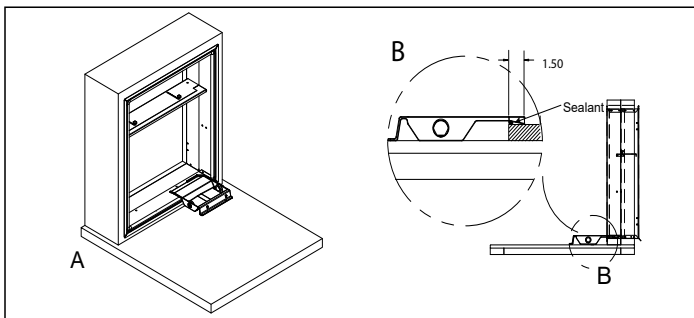

Figure 2

### Install Drain Pan

Attach the drain pan to the closet floor with the appropriate field supplied hardware.

**Important:** To prevent water leaks use only the factory supplied mounting holes. NEVER make penetrations in the drain pan itself.

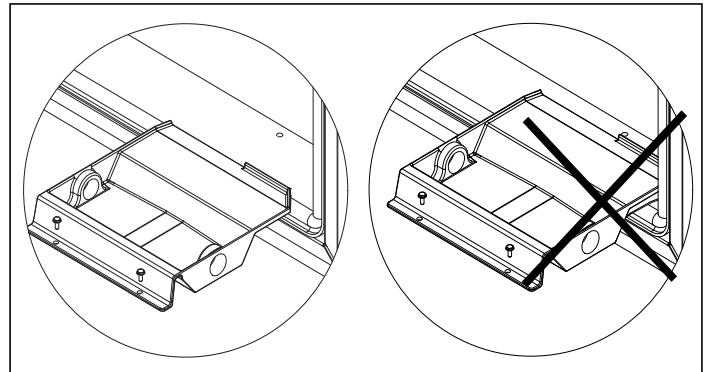

Figure 3

### Install Drain Plug

The drain pan comes with both left and right-hand drain connections locations. Determine which of the two connections will be used to drain the condensate. Then, with the factory supplied drain plug, plug the unused opening.

**Important:** Proper sealant must be applied to the connection to prevent leaks.

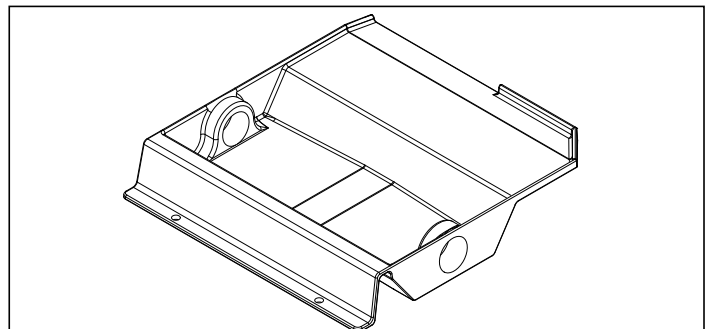

Figure 4

## Install Drain Line

Condensate line routing options are shown below. Choose the one that best suits your installation.

**Important:** Never run the condensate line as shown in Option 4 below, as the drain line will come into contact with the factory-installed isolators beneath the unit.

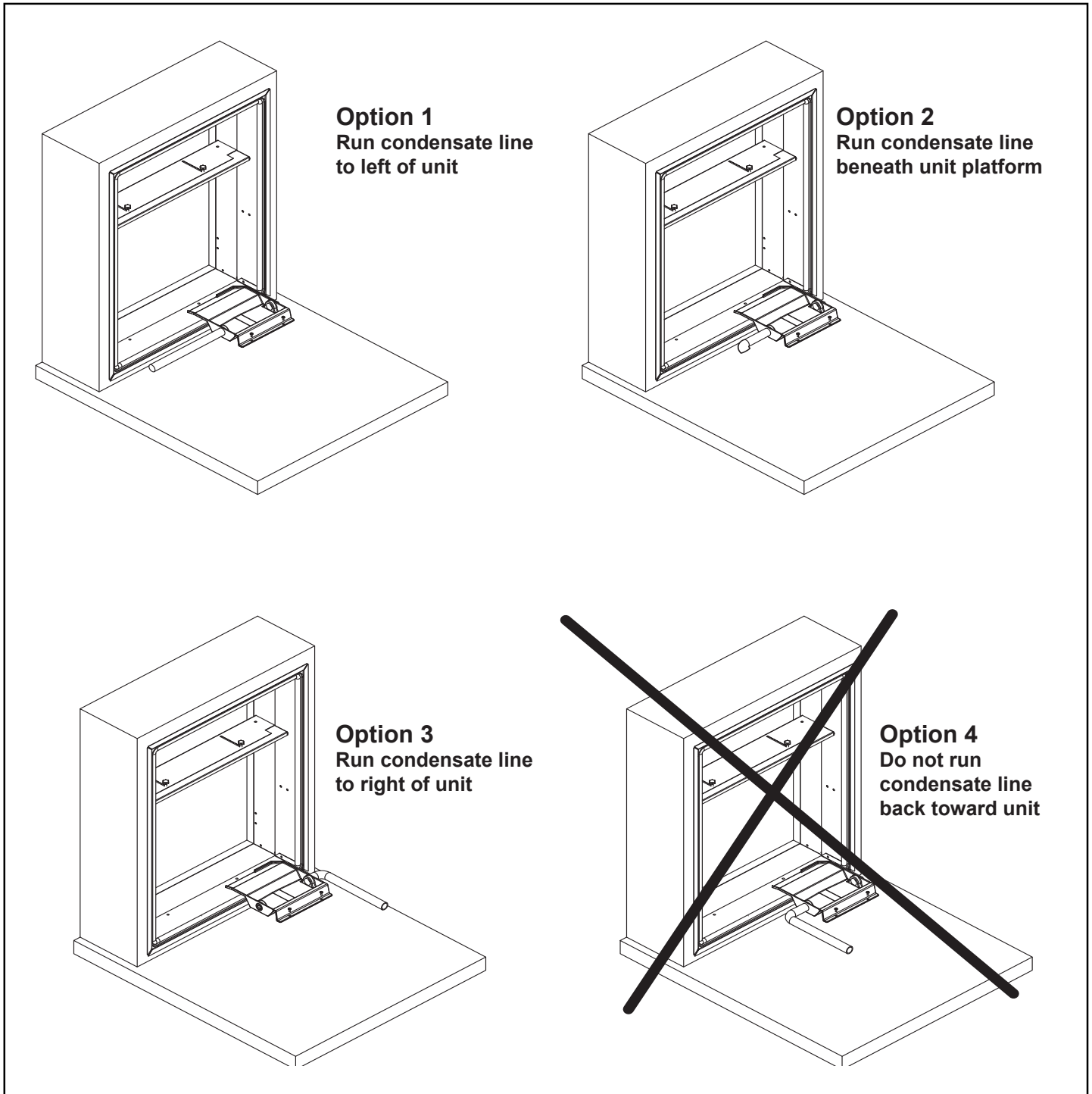

Figure 5

# WIRING



## WARNING

### HIGH VOLTAGE

DISCONNECT ALL POWER BEFORE SERVICING OR INSTALLING THIS UNIT. MULTIPLE POWER SOURCES MAY BE PRESENT. FAILURE TO DO SO MAY CAUSE PROPERTY DAMAGE, PERSONAL INJURY OR DEATH. DO NOT SERVICE THIS UNIT WITHOUT FIRST SHUTTING OFF POWER TO THE UNIT FROM THE CIRCUIT BREAKER AND/OR REMOVING THE UNIT CORD SET PLUG FROM THE WALL OUTLET.



## WARNING

DO NOT ALTER POWER CORD.  
DO NOT REMOVE LDCI OR AFCI CIRCUIT BOARD.  
DO NOT REPLACE TERMINALS OR OTHER PARTS OF THE CORD.  
DO NOT USE CORD IF DAMAGED.  
CONTACT SERVICE PARTS FOR A REPLACEMENT CORD, IF NEEDED.



## WARNING

UNIT MAY **ONLY** BE HARD WIRED WITH A FACTORY SUPPLIED KIT.



## CAUTION

TO AVOID PROPERTY DAMAGE, PERSONAL INJURY OR DEATH DUE TO ELECTRICAL SHOCK, DO NOT USE AN EXTENSION CORD WITH THIS UNIT.



## CAUTION

TO AVOID RISK OF PROPERTY DAMAGE, PERSONAL INJURY OR FIRE, USE ONLY COPPER CONDUCTORS.



## CAUTION

TO AVOID RISK OF PROPERTY DAMAGE, PERSONAL INJURY OR FIRE, DO NOT INSTALL WITH POWER CORD STRETCHED OR UNDER A STRAIN AS THIS MAY CREATE A LOOSE PLUG/RECEPTACLE CONNECTION.



## CAUTION

TO AVOID THE RISK OF PERSONAL INJURY, WIRING TO THE UNIT MUST BE PROPERLY POLARIZED AND GROUNDED.



## WARNING

THIS AIR CONDITIONER IS NOT MEANT TO PROVIDE UNATTENDED COOLING OR LIFE SUPPORT FOR PERSONS OR ANIMALS WHO ARE UNABLE TO REACT TO THE FAILURE OF THIS PRODUCT.  
THE FAILURE OF AN UNATTENDED AIR CONDITIONER MAY RESULT IN EXTREME HEAT IN THE CONDITIONED SPACE CAUSING OVERHEATING OR DEATH OF PERSONS OR ANIMALS. PRECAUTIONS MUST BE TAKEN TO WARN OFF OR GUARD AGAINST SUCH AN OCCURRENCE.

## Indoor Return Air Grille and Ductwork Installation

**AVLWP01A-R & AVLWP01A-L Return Air Grille with Access Panel** A field-supplied (25" x 20") filter can be mounted inside the hinged access door. The door can be installed with the grille oriented at the top of the panel for improved sound attenuation (Recommended for AVH09 & AVH12)



Option 1

### Field Supplied Return Air Grille

A field supplied return air grille divorced from the access panel must have a minimum 250 square inches of free area.



Option 2



**NOTE: All VTAC chassis are shipped with a filter installed (20" x 14" for AVH09, AVH12, & AVH18. 20" x 18" for AVH24). If a different filter holder or location is to be used, the filter on the chassis MUST be removed.**

## Ductwork

The supply duct system should be designed using a recognized method such as the equal fraction or velocity reduction method, using the appropriate duct calculator(s) for the type(s) of duct being used in the system. The duct system should be designed for a maximum friction rate of .3" water column taking into consideration all fittings, registers and/or diffusers.

**NOTE: Do not operate the unit without a supply duct attached. The return air to the VTAC unit MUST NOT be ducted and all units must have a free return air configuration to perform properly.**

## Chassis Installation

 <b>CAUTION</b>	
<p><b>EXCESSIVE WEIGHT HAZARD</b> USE TWO OR MORE PEOPLE WHEN INSTALLING YOUR AIR CONDITIONER. FAILURE TO DO SO CAN RESULT IN BACK OR OTHER INJURY.</p>	

 <b>CAUTION</b>	
<p><b>CUT / SEVER HAZARD</b> SOME EDGES MAY BE SHARP, USE GLOVES OR OTHER HAND PROTECTION WHEN HANDLING UNIT. FAILURE TO DO SO CAN RESULT IN MINOR TO MODERATE PERSONAL INJURY.</p>	

1. Ensure that the wall adapter and louver are installed in accordance with the instructions listed on pages 5-7.
2. Place the chassis into the closet with the outdoor side facing the wall adapter opening.
3. Slide the chassis into the wall adapter until the adapter divider seal is established.

**NOTE: The VTAC chassis must be inserted into the wall adapter so that the adapter divider gasket makes contact with the plastic condenser baffle on the unit. The chassis will fit approximately 2 3/8" into the wall adapter.**

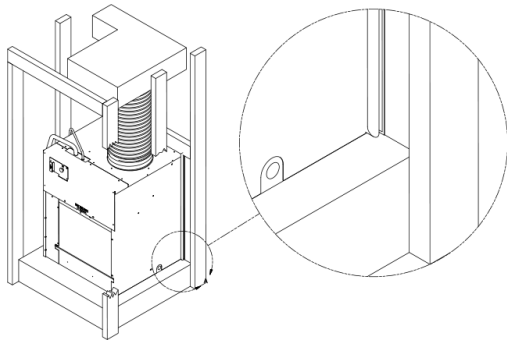

## Remote Thermostat and Low Voltage Control Connection

### Remote Thermostat

All VTAC units are factory configured to be controlled by using a single stage heat/cool remote wall mounted thermostat. The thermostat may be auto or manual changeover as long as the control configuration matches that of the VTAC unit.

#### To connect the wall mounted thermostat:

1. Pull the disconnect switch.
2. Unscrew and remove the control box panel.
3. Select which side to run your thermostat wire.
4. Run the wires through the side hole in the box to reach the connection terminal wiring.
5. Make the connections, appropriately matching the wires as shown in the wiring diagram.
6. Reattach the control box cover.

### Front Desk Control Terminals

The VTAC has built-in provisions for connection to an external switch to control power to the unit. The switch can be a central desk control system door switch.

For desk control operation, connect on side of the switch to the D1 terminal and the other to the D2 terminal. When the circuit is closed, unit operation will stop.

**NOTE: The desk control system and switches must be field supplied.**

#### Maximum Wire Length for Desk Control Switch

AWG Wire Size	Maximum Length (ft.)
24	400
22	600
20	900
18	1500
16	2000

### Auxiliary Fan Control

The VTAC also has the ability to control a 24VAC relay to activate an auxiliary or transfer fan. The outputs are F1 and F2 on the control board.

To connect the relay, simply wire one side of the relay to F1 and the other side to F2.



**NOTE: The relay and auxiliary fans must be field supplied. The relay must be 24VAC @ 100mA or less.**

#### Interface Definition

Terminal Code	Wire Connection Function
C	Common Ground Terminal
GH	Call for High Fan
GL	Call for Low Fan
B	Call for Heat Pump (Reversing Valve)
Y	Call for Compressor
W	Call for Heating (Electric)
R	24VAC to Wall Thermostat

**NOTE: It is the installer's responsibility to ensure that all control wiring connections are made in accordance with the installation instructions. Improper connection of the thermostat control wiring and/or tampering with the unit's internal wiring can void the equipment warranty and may result in property damage, personal injury, or death. Questions concerning proper connections to the unit should be directed to the factory.**

## Final Installation Checklist

 <b>WARNING</b>	
<b>HIGH VOLTAGE</b> DISCONNECT ALL POWER BEFORE SERVICING OR INSTALLING THIS UNIT. MULTIPLE POWER SOURCES MAY BE PRESENT. FAILURE TO DO SO MAY CAUSE PROPERTY DAMAGE, PERSONAL INJURY OR DEATH.	

- Inspect and ensure that all components and accessories have been installed properly and that they have not been damaged during the installation process.
- Ensure that all installation instructions concerning clearances around the unit have been adhered to.
- Check to ensure that the unit air filter, indoor coil, and outdoor coil are free from any obstructions.
- Ensure that the circuit breaker(s) or fuse(s) and supply circuit wire size have been sized correctly.
- Check the condensate water drain(s) to ensure that they are adequate for the removal of condensate water and that they meet approval of the end user.
- Ensure that the entire installation is in compliance with all applicable national and local codes and ordinances having jurisdiction.
- **ENSURE THAT THE SUPPLY VOLTAGE TO THE UNIT IS WITHIN THE OPERATING RANGE**
- Secure all access panels (i.e. front cover and/or control box), apply power to the unit. The unit commissioning should be done at this time to ensure unit function.

**NOTE: Maintaining a log for recording the dates of maintenance and/or service is recommended, and should be suggested to the owner or operator of the equipment.**

- Present the owner or operator of the equipment with the Installation & Operation Manual, all accessory installation instructions, and the name, address and telephone number Warranty Service Company in the area for future reference if necessary.

**NOTE: The unit is not designed to guarantee continuous operation with outdoor ambient conditions greater than 110°F.**

## Chassis Operation

### Fresh Air Door

The fresh air door is an “intake” system. It is opened via a slide mechanism on the front of the chassis located just above the indoor coil. Move the slide left to open and right to close the door. The system is capable of delivering up to 60 CFM of outdoor air.

### Low Ambient Compressor Cut Out

Each chassis is equipped with low ambient protection that is determined by thermistor feedback. The feedback will prevent the compressor from operating at low suction temperatures.



### Room Freeze Protection

This feature will monitor the indoor room conditions and in the event that the room falls below 40°F, the unit will cycle on high fan with the electric heater. This occurs regardless of mode.

### Chassis Final Connections

**With the chassis in place, you are now ready to begin chassis connections:**



- A. Move the thermostat switches to “OFF” and “AUTO”. This will keep the thermostat from cycling the chassis until final connections are complete.
- B. Connect the duct work onto the 10” collar. Plastic wire ties (field supplied) are suggested to secure the duct work in place. Use 2 wire ties, one for each inner and outer flex duct sleeve.
- C. Review the Final Installation Checklist before replacing the power quick disconnect, reconnecting power to the chassis, or operating the chassis.

 <b>WARNING</b>	
<b>HIGH VOLTAGE</b> DISCONNECT ALL POWER BEFORE SERVICING OR INSTALLING THIS UNIT. MULTIPLE POWER SOURCES MAY BE PRESENT. FAILURE TO DO SO MAY CAUSE PROPERTY DAMAGE, PERSONAL INJURY OR DEATH.	

## Service & Warranty

### Servicing / Chassis Quick Changeouts

The chassis is designed for quick disconnect and change out. For minor electrical service, the control box cover lifts straight up after the screws & disconnect head are removed. For major electrical, refrigeration and fan service the chassis may be removed from utility closet.

 <b>WARNING</b>
<p><b>HIGH VOLTAGE</b>  DISCONNECT ALL POWER BEFORE SERVICING OR INSTALLING THIS UNIT. MULTIPLE POWER SOURCES MAY BE PRESENT. FAILURE TO DO SO MAY CAUSE PROPERTY DAMAGE, PERSONAL INJURY OR DEATH.</p> 

## Routine Maintenance

### Performing Routine Maintenance

With the proper maintenance and care, your system will operate economically and dependably. Maintenance can be accomplished easily by referring to the following directions. However, before performing any maintenance, see above stated **WARNING**.

 <b>CAUTION</b>
<p><b>CUT / SEVER HAZARD</b>  SOME EDGES MAY BE SHARP, USE GLOVES OR OTHER HAND PROTECTION WHEN HANDLING UNIT.  FAILURE TO DO SO CAN RESULT IN MINOR TO MODERATE PERSONAL INJURY.</p> 

### Replace Air Filter

A dirty air filter reduces the efficiency of the VTAC and allows lint and dirt to accumulate on the indoor-air coil. Lint and dirt on the indoor-air coil can damage your unit. The air filter should be replaced as it becomes dirty.

To replace the filter (chassis mounted return air filter):

1. Slide the filter clear of the filter rails.
2. Remove the filter.
3. Install new disposable filter.

**NOTE: DO NOT OPERATE YOUR SYSTEM WITHOUT A FILTER IN PLACE OR BLOCK THE FRONT OF THE UNIT RETURN AIR OPENING.**

### To Remove the Chassis from the Closet:

- A. Switch the wall thermostat off.
- B. Pull the Power Disconnect located in the front of the chassis.
- C. Disconnect the power coming into the unit from the main breaker panel or the closet mounted disconnect.
- D. Disconnect the electrical connection.
- E. Disconnect the duct work.
- F. Slide the chassis out of the wall adapter.
- G. Lift the chassis out of the utility closet.

### Inspect and Clean Indoor-air Coil

Eventually, minor amounts of lint and dirt may pass through the filter and collect on the indoor-air. These minor accumulations can be carefully vacuumed away with a brush attachment on a vacuum cleaner. Care must be taken to avoid bending the aluminum fins on the coil. Bent fins should be straightened using a special fin tool available from most HVAC supply depots.

### Inspect Outdoor-Air (OA) Intake and Exhaust

The unit's outdoor-air intake and outdoor-air exhaust paths must remain clear. Check the OA exhaust frequently. Keep it free of all debris, snow, or ice. The OA intake should also be kept free of obstructions. Blocking the OA exhaust or OA intake opening will reduce the efficiency of your unit and could damage it.

### Inspect and Clean Condensate Drain

The condensate drain must be routed to a suitable drainage area. Check the unit condensate drain periodically. Keep it free of anything that may block or impede the flow of condensate water. If there is any accumulation of foreign matter in the drain pipe, it should be removed and cleaned. The entire drain line must be protected from freezing.

### Warranty

All warranty service work must be done by an authorized servicer. See Product Warranty, and consult your dealer or contractor for details.

## Electronic Control Error Code Diagnostics and Test Mode

### Error Code Diagnostics

The VTAC electronic control continuously monitors the VTAC unit operation and will store error codes if certain conditions are witnessed. In some cases the unit may take action and shut the unit off until conditions are corrected.

To access the error code menu press the **'ENTER'** button. If error codes are present they will be displayed. If multiple codes exist you can toggle between error codes using the **'SCROLL'** button. To clear all codes press the **'ENTER'** and **'SCROLL'** buttons for three seconds while in the error code mode. To exit without losing codes press the **"LOW FAN"** button.

## ERROR CODES AND ALARM STATUS

### Unit Control Panel

The display shown below has four (4) digits. The left two digits indicate the error code (1 to 24), The On/Off icons above these two digits indicate the current state of the error code. The right two digits show the history count (up to 99) of the associated error code. The display contains a maintenance icon (wrench) that will illuminate to indicate when the unit needs maintenance.

Error Code	Problem	Action
1	Front Panel Button Stuck For More Than 20 Seconds	Continue to Monitor for "OPEN" (Unstuck) switch. Do not process switch input.
2	Input Voltage Out of Specification (103-127/187-253)	Unit stops, open all relays until voltage is back within specs then resume operation.
3	Indoor Temperature Sensor is Open or Shorted	Unit defaults to 75°F in COOLING or 68°F in HEATING and will continue to operate.
4	Indoor Coil Temperature Sensor is Open or Shorted	The unit's control board defaults 40°F. It will override the sensor and the unit will continue to operate.
5	Outdoor Coil Temperature Sensor is Open or Shorted	The unit defaults to 20°F, overriding the sensor. The unit will continue to operate. Using Elec Heat if available for HEATING. If not available, it will use HEAT PUMP if the outdoor temperature allows.
6	Outdoor Coil > (greater than) 175°F	The unit will shut down for 5 minutes. Resume operation for 3 minutes. If test fails 3 times, the severity is increased and the unit operation is locked out.
7	Indoor Coil < (less than) 30°F for 2 consecutive minutes	The compressor will turn off and the High Fan speed will run. When coil temp reaches 45°F the unit will resume operation after lockout time.
8	Unit Cycles > (greater than) 9 Times per hour	The unit will continue to operate and be monitored.
9	Unit Cycles < (less than) 3 Times per Hour	The unit will continue to operate and be monitored.
10	Room Freeze Protection	Only use if Electric Heat is available. Run High Speed and Electric Heat until room temp reaches 46°F. The unit will display "FRZ" during operation. Logged Only.
11	WallStat Problem or Connection Issue	The unit will not operate.
12	Not Applicable	Not Applicable
13	High Pressure Limit Switch is Open	If unit is cooling or heat pump is on, shut down compressor. Run high fan until switch closes, then resume operation. The third occurrence in 1 hour locks unit out. Applicable to 24K unit only.
14	Not Applicable	Not Applicable
15	Heat Pump Error	If indoor coil temperature is less than ambient temperature for 3 minutes the unit will use electric heat to satisfy the heating demand.
16	Temperature Beyond Operating Limits	Occurs if the ambient temperature range falls below 0°F or greater than 130°F. The error code will remain on until the temperature reaches the operating range and then the unit will return to normal operation.
17	Equipment Doesn't Meet Minimum Configuration	The compressor must be enabled and have at least 2 fan speeds
18	Not Applicable	Not Applicable
19	Not Applicable	Not Applicable
20	Not Applicable	Not Applicable
21	Not Applicable	Not Applicable
22	Outdoor Coil Temperature < 30°F for 2 consecutive Minutes	Unit will use electric heat to satisfy heating demands until the temperature equals or exceeds 45°F. Applicable for Heat Pump models only.
23	Frost Protection	Unit will run active defrost for a minimum of 6 minutes when Heat Pump run time is greater than 60 minutes and outdoor coil temperature is 26°F or less.
24	Not Applicable	Not Applicable

## Obtaining Service

In the event this unit requires repair or servicing beyond what is covered in this manual, contact an authorized service organization.

To obtain an authorized servicer, contact your sales representative.

### CUSTOMER FEEDBACK

Daikin is very interested in all product comments.

Please fill out the feedback form on the following link:

<https://daikincomfort.com/contact-us>

You can also scan the QR code on the right to be directed to the feedback page.



**Amana** is a registered trademark of Maytag Corporation or its related companies and is used under license to Goodman Company, L.P., Houston, TX, USA. All rights reserved.

5151 San Felipe, Suite 500 • Houston, TX 77056 • [www.amana-ptac.com](http://www.amana-ptac.com)  
© 2014 - 2015, 2017 - 2020 Goodman Company, L.P.

## AVAGK01\*\* - VTAC SUBMITTAL

EXTRUDED ALUMINUM; 6063-T5; CLEAR

ANODIZED OR \_\_\_\_\_

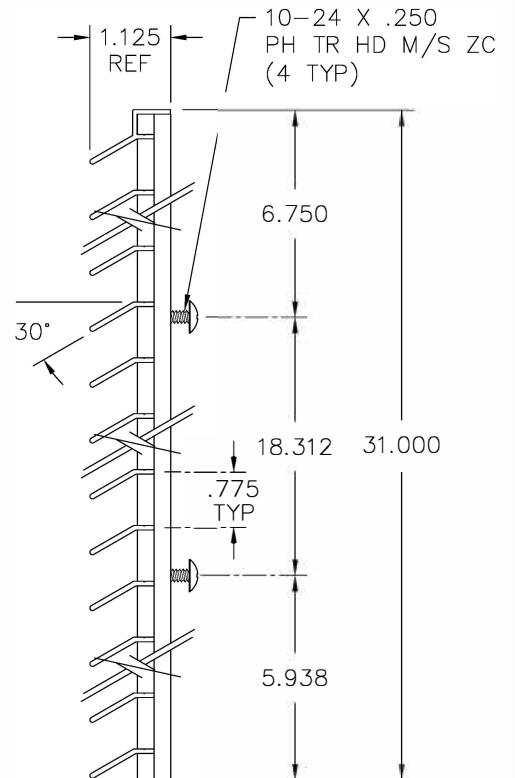
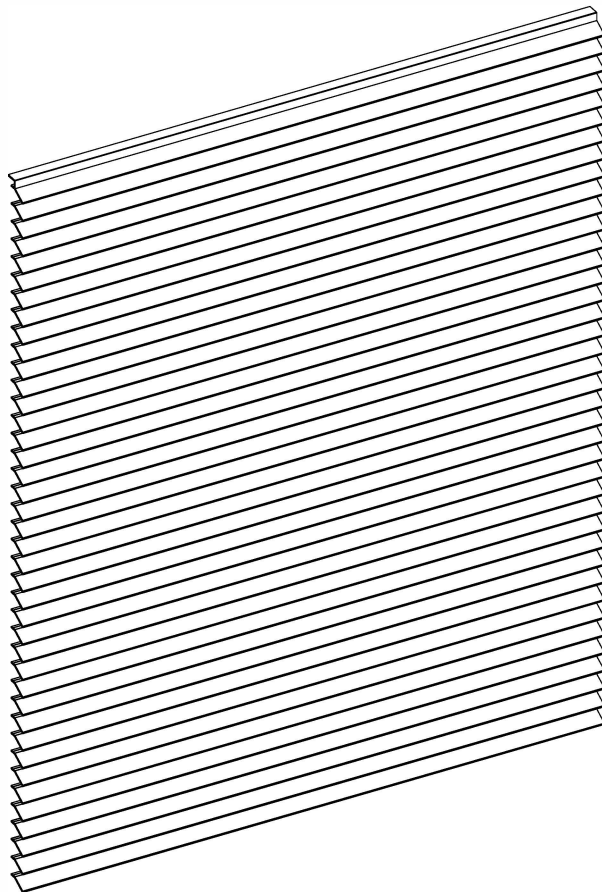
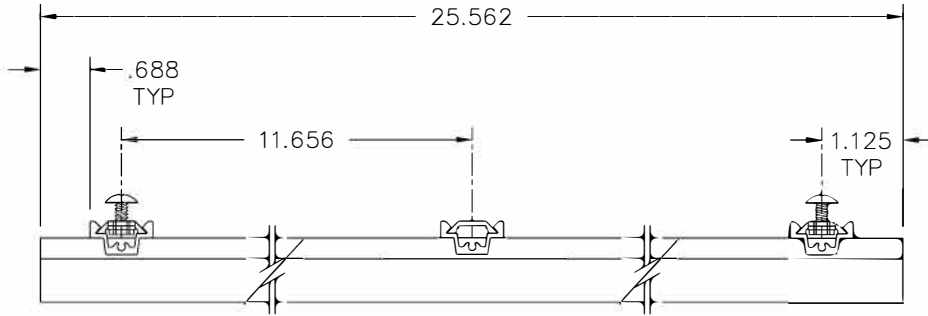

**PROJECT:**

**LOCATION:**

**ARCH./ENGR.:**

**CONTRACTOR:**

**REPRESENTATIVE:**

**DATE:**

01AR013A  
 REV. (A) 04/25/02

ALL STATED SPECIFICATIONS ARE SUBJECT TO CHANGE WITH OUT NOTICE OR OBLIGATION.

# RETURN AIR GRILLE / ACCESS PANEL FOR AVH UNITS INSTALLATION INSTRUCTIONS

## Table of Contents

Parts Included in this Kit.....	2
Parts NOT included in this Kit.....	2
Installation .....	2
Left Side Mounting .....	3
Right Side Mounting .....	4

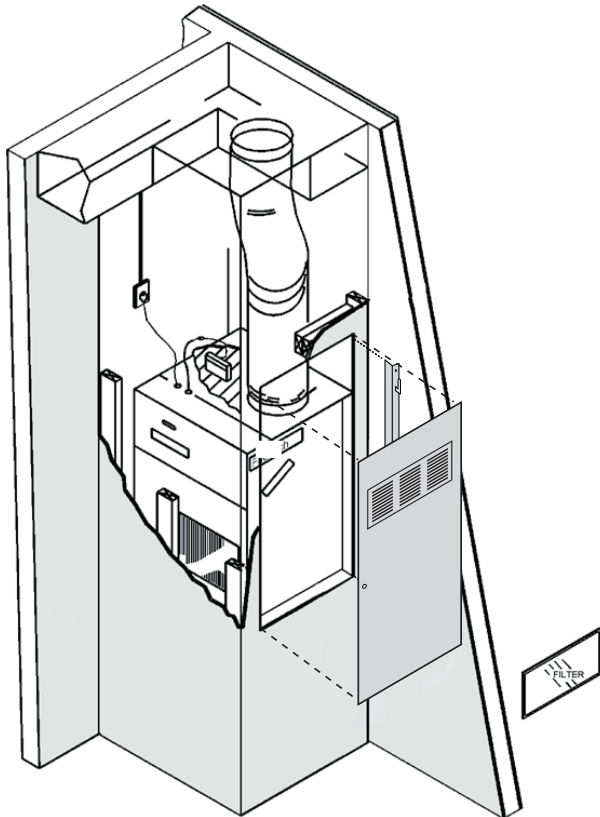

**PROP 65 WARNING  
FOR CALIFORNIA CONSUMERS**

**! WARNING**

Cancer and Reproductive Harm -  
[www.P65Warnings.ca.gov](http://www.P65Warnings.ca.gov)

0140M00513-A



**WARNING**

Only personnel that have been trained to install, adjust, service or repair (hereinafter, "service") the equipment specified in this manual should service the equipment. The manufacturer will not be responsible for any injury or property damage arising from improper service or service procedures. If you service this unit, you assume responsibility for any injury or property damage which may result. In addition, in jurisdictions that require one or more licenses to service the equipment specified in this manual, only licensed personnel should service the equipment. Improper installation, adjustment, servicing or repair of the equipment specified in this manual, or attempting to install, adjust, service or repair the equipment specified in this manual without proper training may result in product damage, property damage, personal injury or death.

IO-917  
01/2020

**Amana** is a registered trademark of Maytag Corporation or its related companies and is used under license to Goodman Company, L.P., Houston, TX, USA. All rights reserved.

5151 San Felipe, Suite 500 • Houston, TX 77056 • [www.amana-ptac.com](http://www.amana-ptac.com)  
© 2018 Goodman Company, L.P.



## Return Air Grille / Access Panel

For use with VTAC units only.

**NOTE:** The following installation instructions apply to the VTAC series units only. Refer to Chassis Installation / Operation Manual for additional information.

### Parts Included in this Kit

ITEM
AVLWP01A-L Return Air Grille / Access Panel (58" Tall x 29" Wide)
2x Mounting Bracket (left and right)
Mounting Screws

### Parts NOT Included in the Kit

ITEM
25" x 20" Filter
5/32" Allen wrench for latch mechanism operation

Frame and sheetrock the access hole to 27" wide and 55 3/4" tall. The bottom of the opening should be at the same level as the base platform or below chassis bottom. The chassis must fit thru this opening. The chassis is 23 1/8" wide and 32 1/4", 47 15/16", or 51 7/8" tall (consult chassis specifications for actual dimensions).

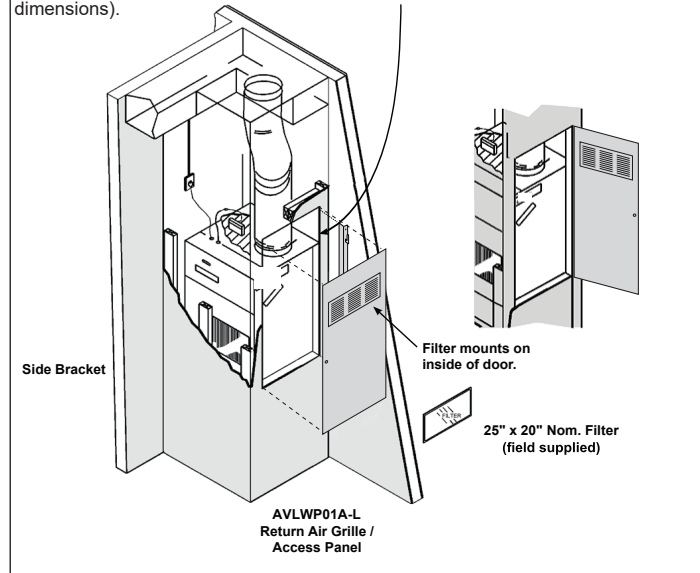
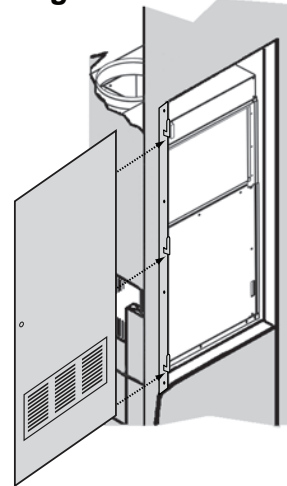

Figure 1

## Installation

Determine the orientation of the door.  
 The AVLWP01A-L Kit comes with two mounting hinges. One mounts to the left side of the opening and locates the return air openings at the lower portion of the door (View A).  
 The other mounts the hinge to the right side of the opening and locates the return air openings at the upper portion of the door (View B).  
 This provides an option for the direction that the door will open. More importantly it can aid in sound attenuation by locating the return air openings away from the evaporator opening on the unit.

View A  
Left hinge



View B  
Right hinge

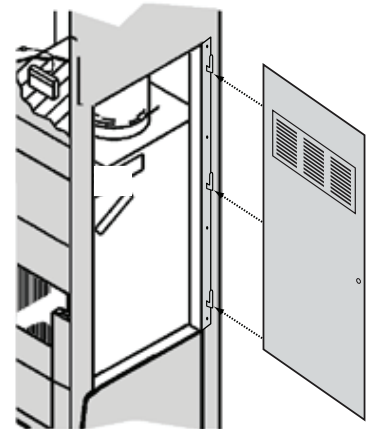

Figure 2

## Left Side Mounting

1. Mount the Side Bracket to the left side of the wall opening. The Side Bracket must be plumb (vertical). Secure with four #8 x 1/4" pan-head screws.  
**NOTE:** Hinge tabs must point upward.

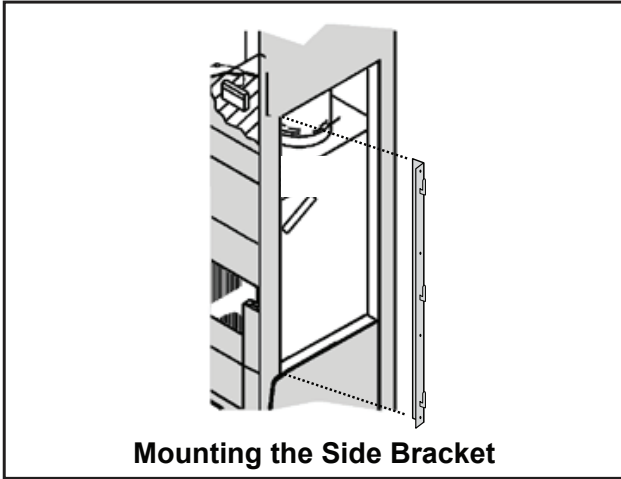

Figure 3

2. Install door onto the Side Bracket. Be sure that the access door has engaged the three tabs, and the door is against the side mounting bracket.

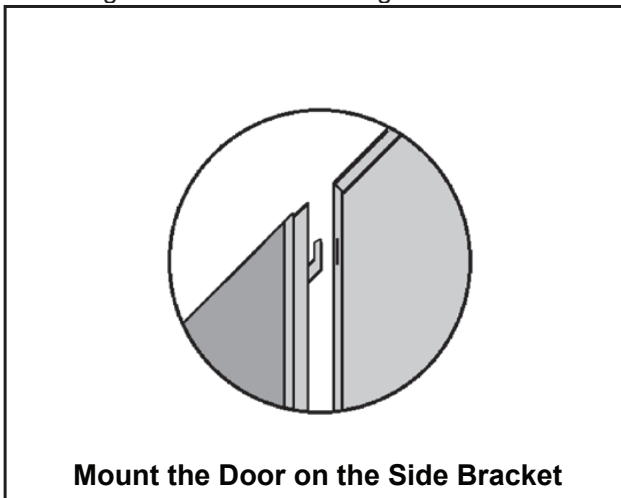

Figure 4

3. Close the door. Draw a temporary horizontal reference line on the wall adjacent to the center of the latch mounting hole.

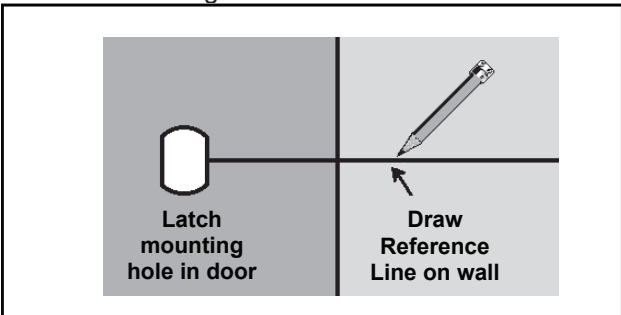

Figure 5

4. Attach the latch bracket to the opening, aligning the bottom of the bracket with the reference line. Use two #18 x 1/4 screws. Do not tighten.

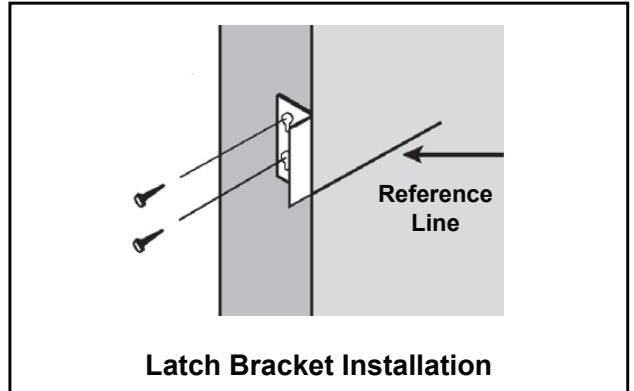

Figure 6

5. Slide the bracket upward and tighten the mounting screws.

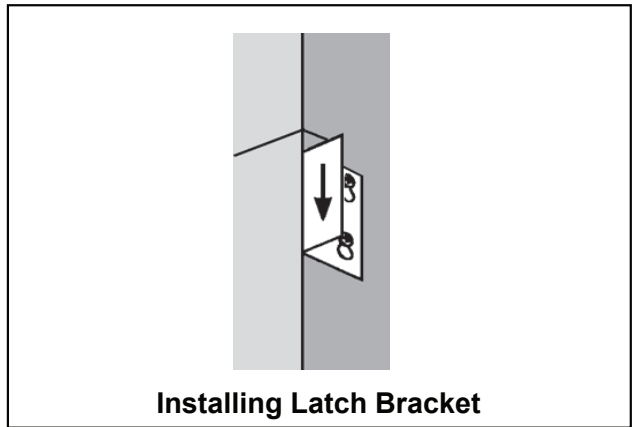

Figure 7

**NOTE:** The latch mechanism should already be factory mounted. This assembly is shown for reference. The latch arm is adjustable to provide a secure, rattle-free installation. Install the filter.

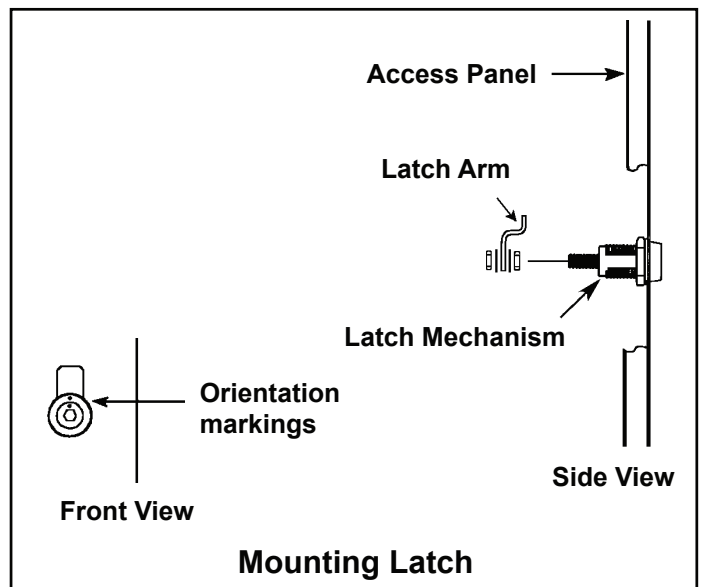
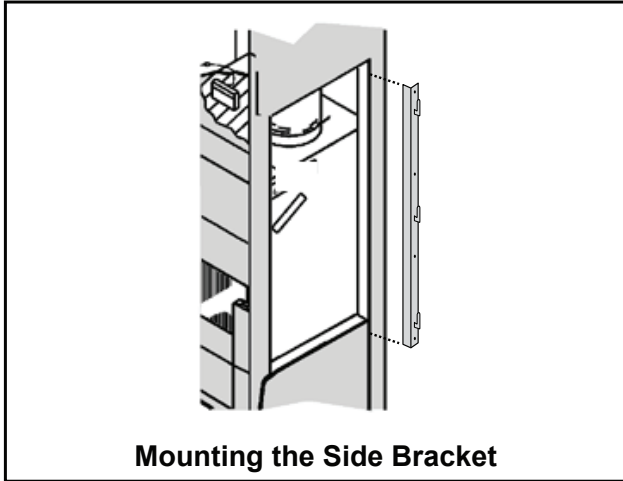

Figure 8

## Right Side Mounting

1. Mount the Side Bracket to the left side of the wall opening. The Side Bracket must be plumb (vertical). Secure with four #8 x 1 1/4" pan-head screws.  
**NOTE:** Hinge tabs must point upward.



**Figure 9**

2. Install door onto the Side Bracket. Be sure that the access door has engaged the three tabs, and the door is against the side mounting bracket.

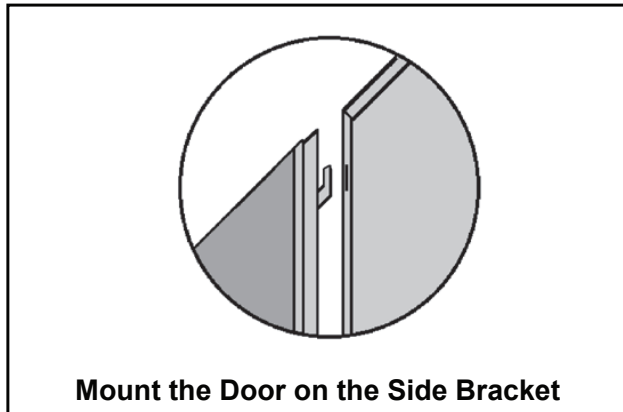

**Figure 10**

3. Close the door. Draw a temporary horizontal reference line on the wall adjacent to the center of the latch mounting hole.

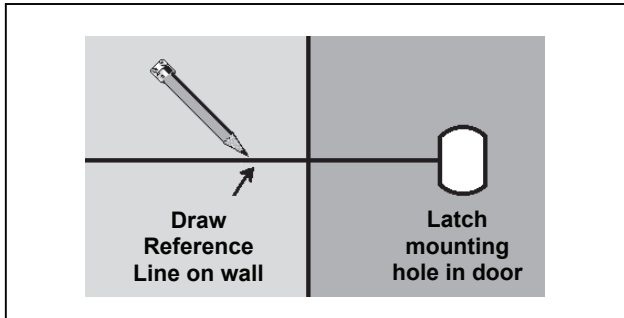

**Figure 11**

4. Attach the latch bracket to the opening, aligning the bottom of the bracket with the reference line. Use two #18 x 1 1/4 screws. Do not tighten.

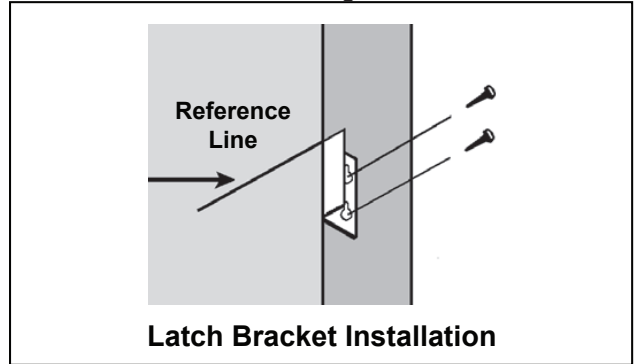

**Figure 12**

5. Slide the bracket upward and tighten the mounting screws.

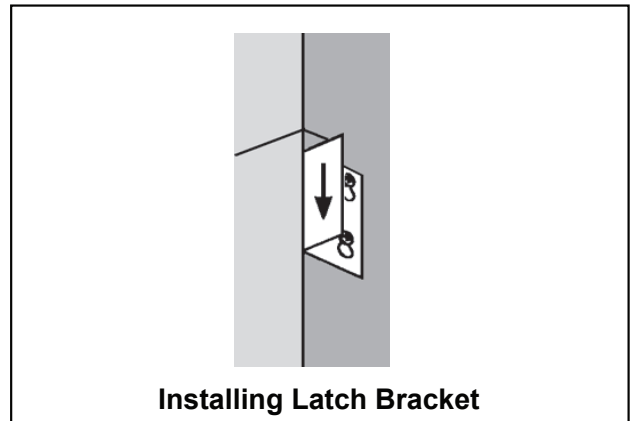

**Figure 13**

**NOTE:** The latch mechanism should already be factory mounted. This assembly is shown for reference. The latch arm is adjustable to provide a secure, rattle-free installation. Install the filter.

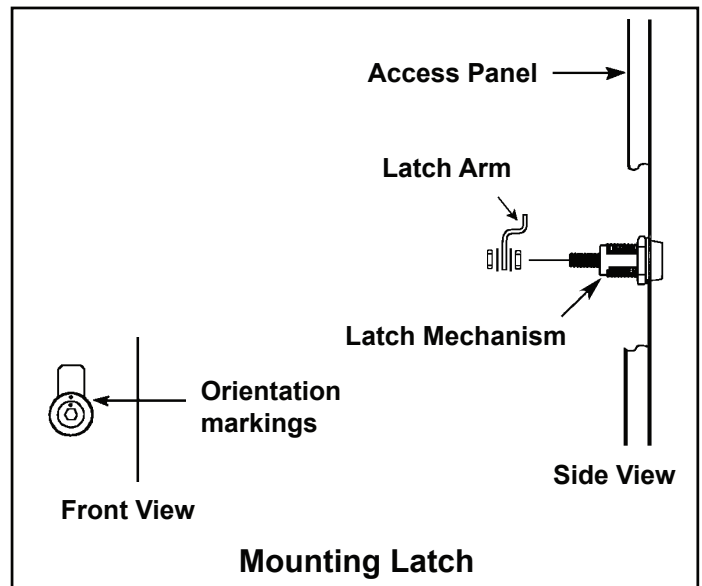

**Figure 14**

**THIS PAGE INTENTIONALLY LEFT BLANK**

**THIS PAGE INTENTIONALLY LEFT BLANK**

**THIS PAGE INTENTIONALLY LEFT BLANK**

**CUSTOMER FEEDBACK**

We are very interested in all product comments.

Please fill out the feedback form on one of the following links:

Amana® Brand Products: (<http://www.amana-hac.com/about-us/contact-us>).

You can also scan the QR code on the right for the product brand you purchased to be directed to the feedback page.



AMANA® BRAND

**Amana** is a registered trademark of Maytag Corporation or its related companies and is used under license to Goodman Company, L.P., Houston, TX, USA. All rights reserved.

5151 San Felipe, Suite 500 • Houston, TX 77056 • [www.amana-ptac.com](http://www.amana-ptac.com)

© 2018 Goodman Company, L.P.

# SLEEVE ADAPTER KIT INSTALLATION INSTRUCTIONS

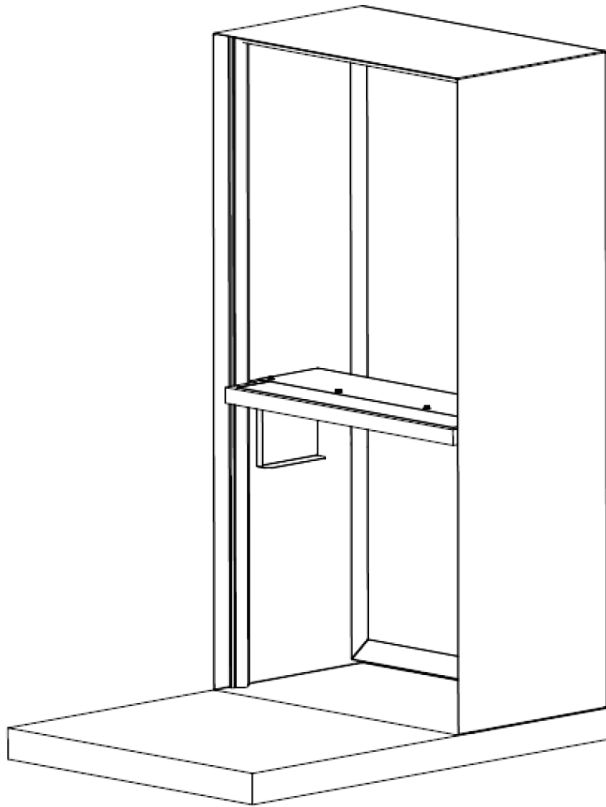

## Table of Contents

Installation Instructions .....	2
Verify Closet and Doorway Dimensions .....	2
Check Included Parts .....	2
Check Field Supplied Parts .....	3
Prepare Existing Sleeve .....	3
Install Amana Baffle.....	4
Install VTAC Adapter Tray .....	5
Install VTAC Adapter .....	5
VTAC and Stand Installation.....	6

**PROP 65 WARNING  
FOR CALIFORNIA CONSUMERS**

**! WARNING**

Cancer and Reproductive Harm -  
[www.P65Warnings.ca.gov](http://www.P65Warnings.ca.gov)

0140M00513-A



**WARNING**

Only personnel that have been trained to install, adjust, service or repair (hereinafter, "service") the equipment specified in this manual should service the equipment. The manufacturer will not be responsible for any injury or property damage arising from improper service or service procedures. If you service this unit, you assume responsibility for any injury or property damage which may result. In addition, in jurisdictions that require one or more licenses to service the equipment specified in this manual, only licensed personnel should service the equipment. Improper installation, adjustment, servicing or repair of the equipment specified in this manual, or attempting to install, adjust, service or repair the equipment specified in this manual without proper training may result in product damage, property damage, personal injury or death.

IO-916  
10/2019

**Amana** is a registered trademark of Maytag Corporation or its related companies and is used under license to Goodman Company, L.P., Houston, TX, USA. All rights reserved.

5151 San Felipe, Suite 500 • Houston, TX 77056 • [www.amana-ptac.com](http://www.amana-ptac.com)  
© 2014 - 2015, 2017 - 2018 Goodman Company, L.P.



## Sleeve Adapter Kit

For use with 9K-12K AVH VTAC  
Air Conditioner and Amana / First Company® SPU Series  
wall sleeve

**NOTE:** The following installation instructions apply to the Amana AVAKFC01A Sleeve Adapter Kit. This kit is designed to adapt the 9K-12K AVH VTAC chassis into an existing Amana / First Company® SPU Series wall sleeve only.

There are no provisions for adapting supply ductwork, electrical connections, or condensate drain lines. These items remain the responsibility of the equipment owner.

### STOP!

**Critical Closet Enclosure Dimensions Apply!**  
(See Figure 1)  
**Please read entire instruction manual before proceeding!**

## Verify Closet and Doorway Dimensions

**Important!** Verify that closet meets minimum clearance requirements prior to proceeding with installation. (See Step 1 below and Figure 1)

The following clearance dimensions are required to allow replacement VTAC chassis and adapter to fit into the existing closet enclosure:

1. The closet width must have a minimum clearance of 4 1/4" on either side of the existing sleeve. (See Figure 1A)
2. The closet depth must have a minimum of 27" from the existing sleeve edge to the front of the closet. (See Figure 1A)
3. The closet/doorway opening must be a minimum of 27". (See Figure 1A)
4. There must be a minimum of 6" from the bottom of the sleeve tray to the closet floor. (See Figure 1B)

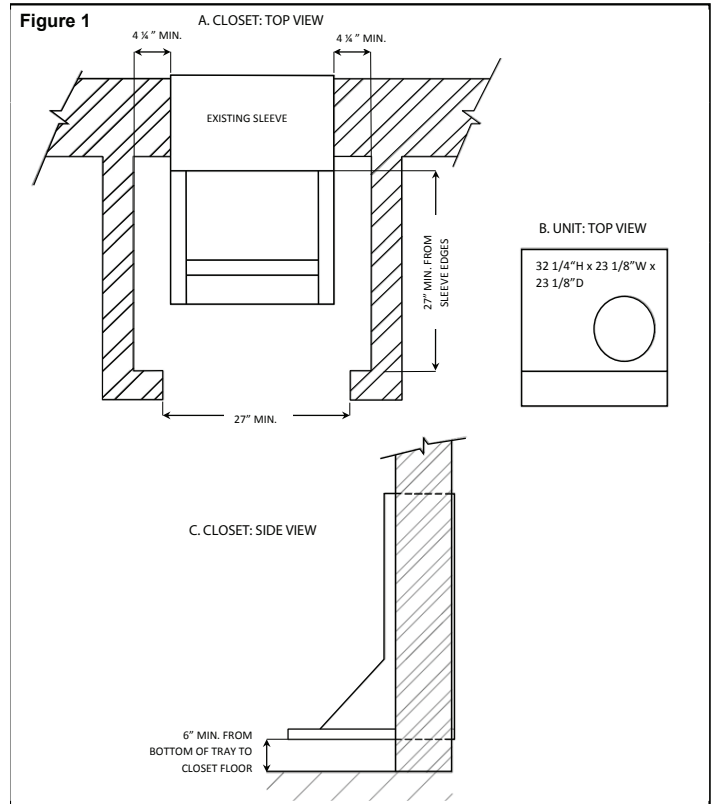

Figure 1

## Check Included Parts

**Important!** Make sure the box contains all parts listed below. Inspect for defective parts. Be sure to verify the adapter dimension. i.e.: 23" ID, 19 5/8" OD and 41 3/4" (See Figure 2)

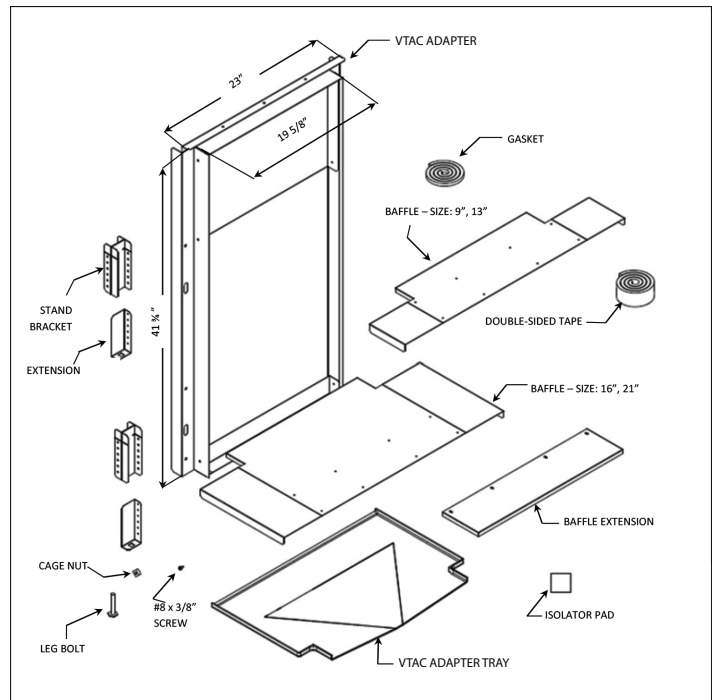

Figure 2

**Included Packaging Contents:**

PART	QNTY
AVAKFC01A (9530300) Installation Manual	1 ea.
VTAC Adapter	1 ea.
Baffle for sleeve - Size: 9, 13	1 ea.
Baffle for sleeve - Size: 16, 21	1 ea.
Baffle Extension	1 ea.
#8 x 3/8" Screw	8 ea.
Stand Brackets Extension	2 ea.
VTAC Adapter Tray	1 ea.
3/8" x 3/8" x 28" L Adhesive Gasket	1 ea.
Stand Brackets	4 ea.
Cage Nuts	2 ea.
Leg Bolts with Isolator Pad	2 ea.
Double-sided Tape	2 ea.



**Check Field Supplied Parts**

**Important!** Make sure you have the following parts and tools before attempting installation. Proper clothing, shoe attire, gloves and eyewear protection is recommended.

Field Supplied Parts and Tools required\*

ITEM
#8 and #10 Hex-Head Driver or Drill
Reciprocating Saw (Jigsaw) with metal-cutting blade
Level
Tape Measure
Silicone Caulking
(16) #8 sheet metal self-drilling screws
1/2" Ratchet
(2) Drywall Screws

\*For installations where the unit is mounted more than 12" above floor, you will also need a scrap of 2" X 4" lumber.

 <b>WARNING</b>	
<p><b>HIGH VOLTAGE</b>  DISCONNECT ALL POWER BEFORE SERVICING OR INSTALLING THIS UNIT. MULTIPLE POWER SOURCES MAY BE PRESENT. FAILURE TO DO SO MAY CAUSE PROPERTY DAMAGE, PERSONAL INJURY OR DEATH. DO NOT SERVICE THIS UNIT WITHOUT FIRST SHUTTING OFF POWER TO THE UNIT FROM THE CIRCUIT BREAKER AND/OR REMOVING THE UNIT CORD SET PLUG FROM THE WALL OUTLET.</p>	

**Prepare Existing Sleeve**

**Important!** Your adapter will work only if existing wall sleeve is installed with a 1/2 bubble slope towards the outside to accommodate for proper condensate flow.

1. Check pitch of sleeve. Must be pitched at least 1/2 bubble (.35"/ft) to outside. (Figure 3)
2. Remove existing baffle. Remove screws and detach from supporting flanges. Cut sealant.
3. Cut edge of sleeve gusset flush or below gasket line using reciprocating saw. (Figure 4)  
*Tip: Angle blade to ensure gasket remains intact and without damage.*
4. Clean existing sleeve and gaskets. Do not use solvent, instead use warm soapy water.
5. Measure sleeve depth. It should measure 9, 13, 16 or 21 inches deep.

 <b>CAUTION</b>	
<p><b>CUT / SEVER HAZARD</b>  SOME EDGES MAY BE SHARP, USE GLOVES OR OTHER HAND PROTECTION WHEN HANDLING UNIT.  FAILURE TO DO SO CAN RESULT IN MINOR TO MODERATE PERSONAL INJURY.</p>	

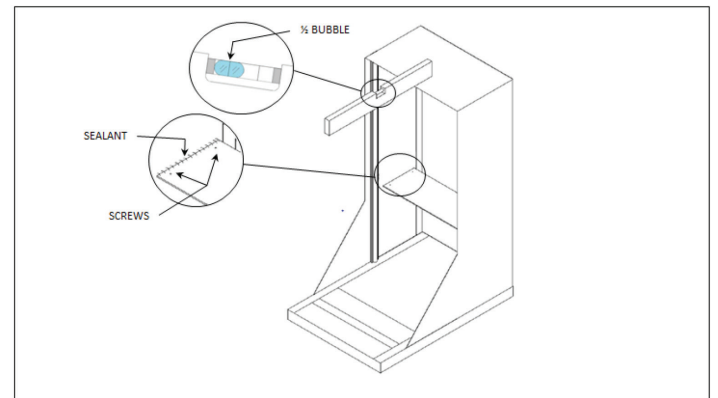

**Figure 3**

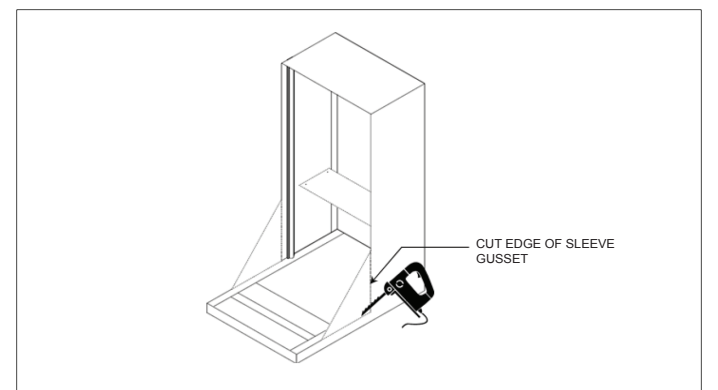

**Figure 4**

## Install Amana Baffle

Bend the designated baffle (9", 13" or 16", 21" depth) at the perforation. (See Figure 5)

**CAUTION**

**CUT / SEVER HAZARD**  
SOME EDGES MAY BE SHARP, USE GLOVES OR OTHER HAND PROTECTION WHEN HANDLING UNIT.  
FAILURE TO DO SO CAN RESULT IN MINOR TO MODERATE PERSONAL INJURY.



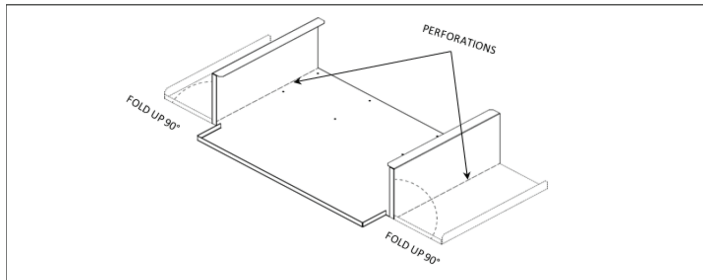

**Figure 5**

1. On 13" & 21" Depth Applications Only: Attach the baffle extension with 4 supplied screws. (See Figure 6)
2. Attach supplied gasket to designated baffle. (See Figure 6)

**CAUTION**

**CUT / SEVER HAZARD**  
SOME EDGES MAY BE SHARP, USE GLOVES OR OTHER HAND PROTECTION WHEN HANDLING UNIT.  
FAILURE TO DO SO CAN RESULT IN MINOR TO MODERATE PERSONAL INJURY.



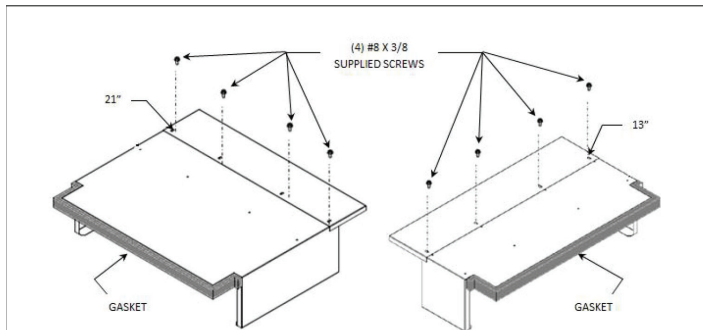

**Figure 6**

Install the newly prepared Amana baffle by placing onto the supported flanges of the sleeve. (See Figure 7)

**CAUTION**

**CUT / SEVER HAZARD**  
SOME EDGES MAY BE SHARP, USE GLOVES OR OTHER HAND PROTECTION WHEN HANDLING UNIT.  
FAILURE TO DO SO CAN RESULT IN MINOR TO MODERATE PERSONAL INJURY.



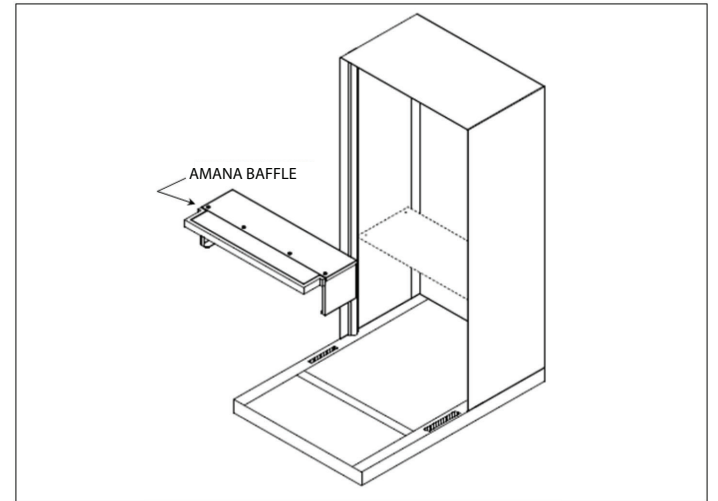

**Figure 7**

Secure baffle to the wall using #8 sheet metal self-drilling screw on both sides. (See Figure 8)

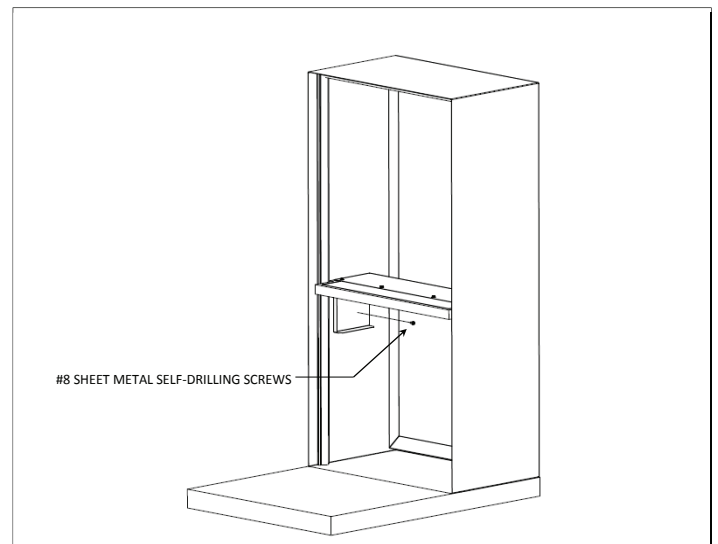

**Figure 8**

## Install VTAC Adapter Tray

1. Apply double-sided tape on gasket (as shown) to assist in the installation. (See Figure 9)
2. Insert tray lip between the sleeve gasket and align tray shoulder flush against sleeve vertical edge.
3. Once you have verified that tray is flush with cut sleeve, press tray into place with double-sided tape.  
*Tip: It's important to verify tray alignment before pressing tray into place. Double-sided tape will be difficult to remove if alignment is incorrect.*

**CAUTION**

**CUT / SEVER HAZARD**  
SOME EDGES MAY BE SHARP, USE GLOVES OR OTHER HAND PROTECTION WHEN HANDLING UNIT.  
FAILURE TO DO SO CAN RESULT IN MINOR TO MODERATE PERSONAL INJURY.



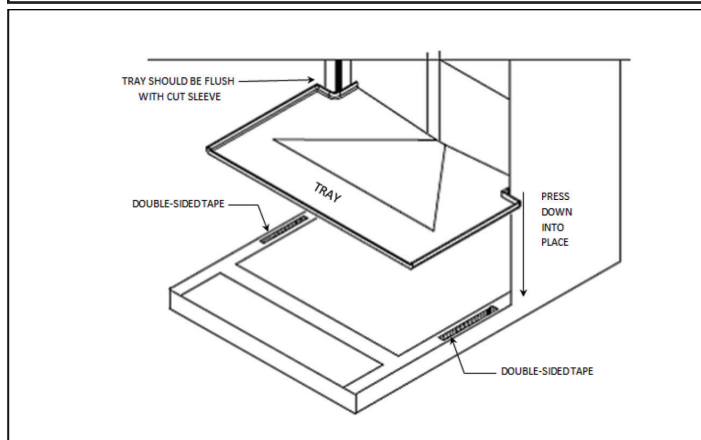

Figure 9

## Install VTAC Adapter

1. Unpack new Amana VTAC. Make sure the red drain plugs are in place prior to installation. (See Figure 10A) Use 1/2" Ratchet to tighten the drain plugs if necessary.  
*Tip: See VTAC Installation & Operation Manual for more information.*
2. Tilt VTAC down on pallet that came with the shipping as shown on Figure 10A.
3. Place 23" ID-side of adapter over backside of VTAC. Line up adapter to the 2 bottom holes of the VTAC and mark each VTAC screw that lines up with the 4 adapter slots. Place adapter aside and remove the remaining (unmarked) 5 screws that do not align with the slots, and set them aside in a secure place for later use. (See Figure 10B)
4. Slide adapter up into place, making sure that adapter hem is latched securely into cover flange. (See Figure 10A-A)  
*Tip: If adapter placement is correct, the 5 screw*

*holes should now align.*

5. Place 23" ID-side of adapter over backside of VTAC. Secure adapter flush to VTAC by reinstalling the 5 screws into the now visible holes.
6. Remove the back VTAC isolating foot (underside of unit, closest to adapter) by removing screws. Once foot is removed, replace both screws back into unit.

**Note:** Refer to Amana / First Company® Installation Manual for detailed information on removal of Amana / First Company® Unit



**CAUTION**

**CUT / SEVER HAZARD**  
SOME EDGES MAY BE SHARP, USE GLOVES OR OTHER HAND PROTECTION WHEN HANDLING UNIT.  
FAILURE TO DO SO CAN RESULT IN MINOR TO MODERATE PERSONAL INJURY.



**CAUTION**

**EXCESSIVE WEIGHT HAZARD**  
USE TWO OR MORE PEOPLE WHEN INSTALLING YOUR AIR CONDITIONER.  
FAILURE TO DO SO CAN RESULT IN BACK OR OTHER INJURY.



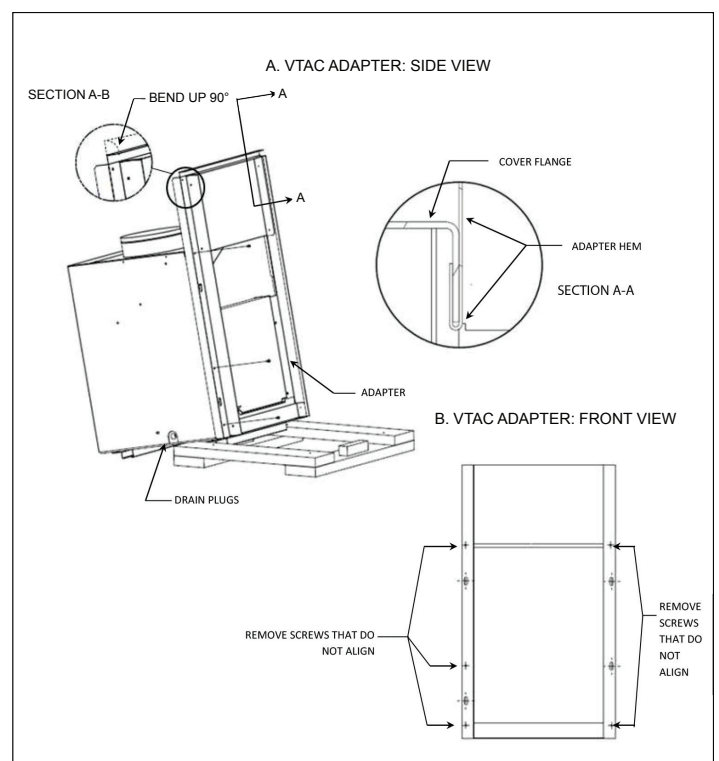

Figure 10

## VTAC and Stand Installation

**Important!** Make sure you read all directions below before starting this step.

1. Lift and place new VTAC unit (along with attached adapter) onto tray and push flush against existing sleeve. When correctly installed, sleeve gasket will press against top of adapter.
2. The top of adapter will overlap the top of the existing sleeve. Secure with at least 2 #8 sheet metal self-drilling screws through the pre-punched holes immediately. This will hold the unit in position. (See Figure 11A)

**Note:** If using the 90° bent flange (the Amana / First Company® sleeve is flush with the inner wall), secure the flange to the wall. (See Figure 11B)

3. Measure the height from the bottom of the VTAC to the floor. (See “H” in Figure 11) height.
  - A. Height (H) 12” or less: bracket + bracket stand (See Figure 12A)
    1. Slide 2 stand bracket into front isolating foot.
    2. Place supplied cage nut at the bottom of the extension angle.
    3. Insert supplied leg bolt and turn it all the way to end of the thread.
    4. Install extension angle to approximate 1 inch above the ground.
    5. Secure with at least 2 screws.
    6. Unscrew till tight.
  - B. Height (H) more than 12”: bracket + wood stand (See Figure 12B).
    1. Slide 2 stand bracket into front isolating foot.
    2. Premeasure and cut wood to proper length. Total 2 pieces of wood studs.
    3. Slide wood stud into stand bracket and secure, using at least 2 field supplied #8.
    4. screws per side. (total of 2 screws per stand, 4 for both stands).
4. Refer to the VTAC A-Series Installation and Operation Manual to complete the installation (Electrical, Condensate Drain, Supply Air, etc). Do not unplug the front drain.

**Note:** Refer to Amana / First Company® Installation Manual for detailed information on removal of Amana / First Company® Unit.

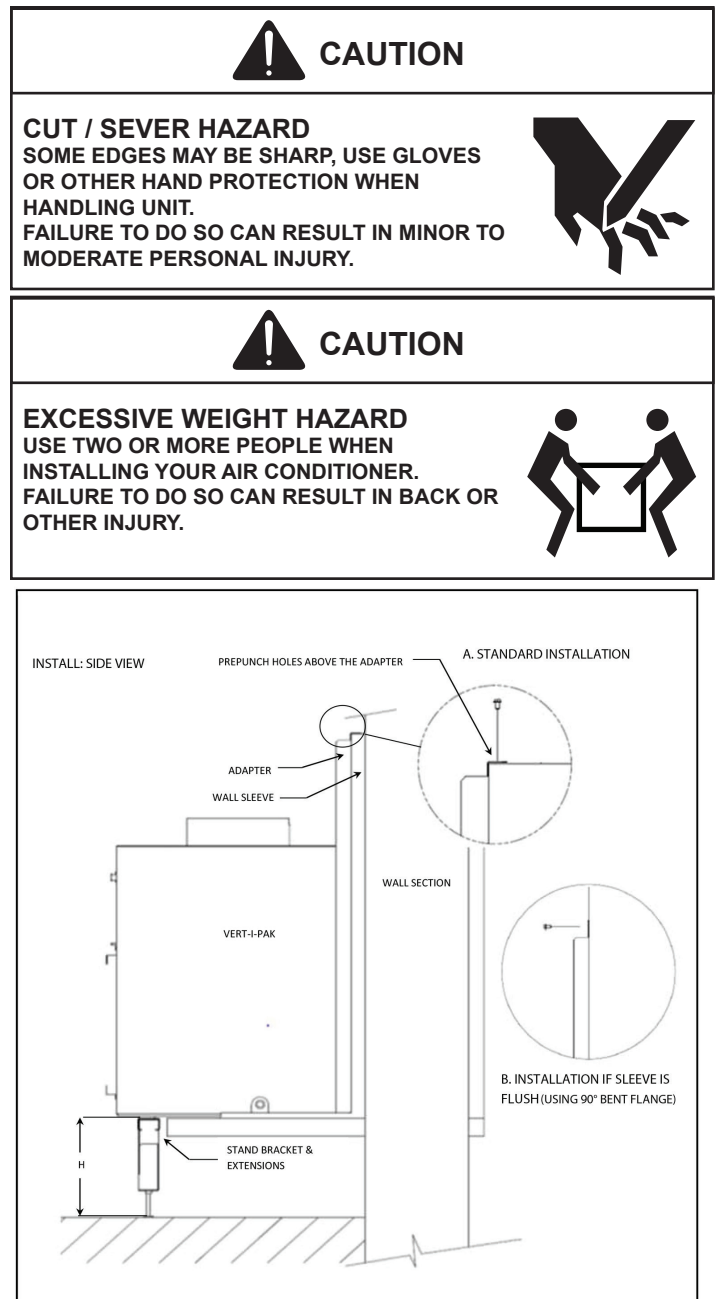

Figure 11

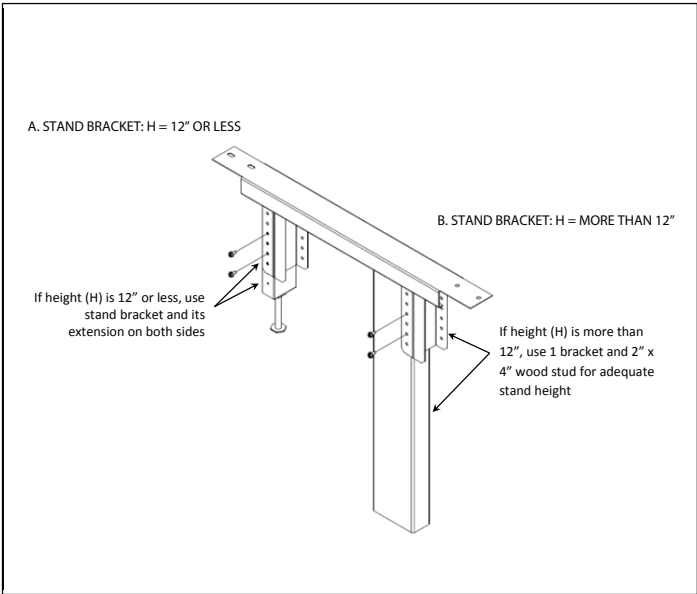

Figure 12

THIS PAGE INTENTIONALLY LEFT BLANK

#### **CUSTOMER FEEDBACK**

We are very interested in all product comments.

Please fill out the feedback form on one of the following links:

Amana® Brand Products: (<http://www.amana-hac.com/about-us/contact-us>).

You can also scan the QR code on the right for the product brand you purchased to be directed to the feedback page.



AMANA® BRAND

**PTAC Direct Sales, Inc.**  
**185 S. Kimball Ave., Suite 130**  
**Southlake, TX 76092**  
**877.454.7822 (T)**  
**877.647.6408 (F)**

**Amana** is a registered trademark of Maytag Corporation or its related companies and is used under license to Goodman Company, L.P., Houston, TX, USA. All rights reserved.

5151 San Felipe, Suite 500 • Houston, TX 77056 • [www.ptacdirect.com](http://www.ptacdirect.com)

© 2014 - 2015, 2017 - 2018 Goodman Company, L.P.