



FRIEDRICH

Kühl® Room Air Conditioners

PRECISION
INVERTER®

PTAC Direct Sales, Inc.
185 S. Kimball Ave., Suite 130
Southlake, TX 76092
877.454.7822 (T)
877.647.6408 (F)

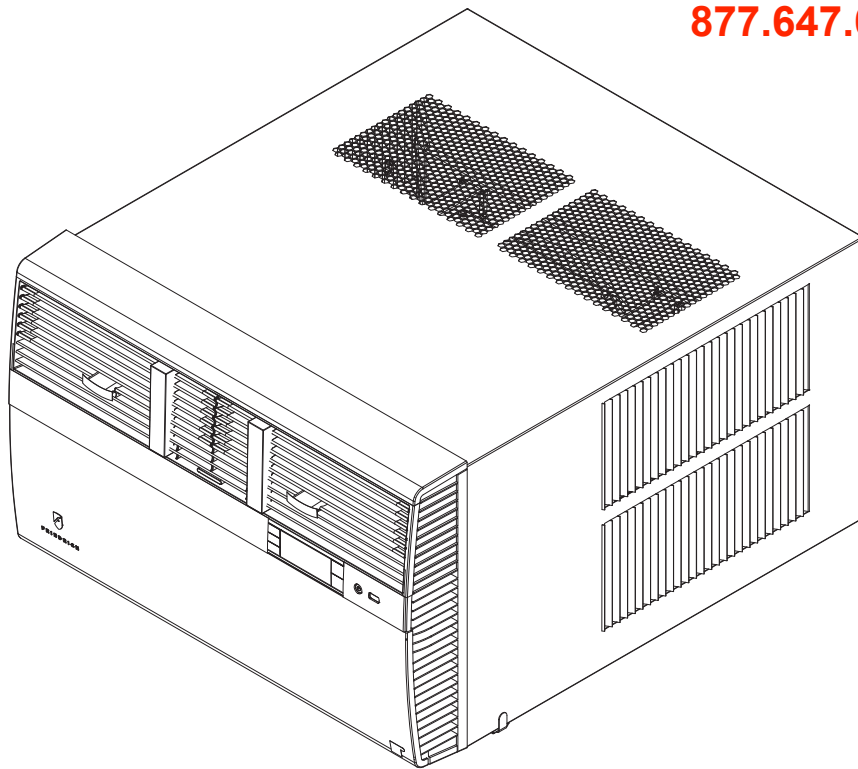

Standard Chassis Models Using R-32 Refrigerant

Kühl

115-Volt: KCVS08B10A, KCVS12B10A, KCVS14B10A

230-Volt: KCVS12B30A, KCVS16B30A, KCVS18B30A, KCVS24B30A, KCVL28B30A, KCVL36B30A

Kühl +

Heat Pump and Electric Heat

115-Volt: KHVS10B11A

230-Volt: KHVS12B33A, KHVM24B34A, KHVL28B35A

Kühl +

Electric Heat

230-Volt: KEVS16B33A, KEVL36B35A

THE EXPERTS IN ROOM AIR CONDITIONING

www.PTACdirect.com

RECOGNIZE THIS SYMBOL AS AN INDICATION OF IMPORTANT SAFETY INFORMATION!

WARNING

THESE INSTRUCTIONS ARE INTENDED AS AN AID TO QUALIFIED SERVICE PERSONNEL FOR PROPER INSTALLATION, ADJUSTMENT AND OPERATION OF THIS UNIT. READ THESE INSTRUCTIONS THOROUGHLY BEFORE ATTEMPTING INSTALLATION OR OPERATION. FAILURE TO FOLLOW THESE INSTRUCTIONS MAY RESULT IN IMPROPER INSTALLATION, ADJUSTMENT, SERVICE OR MAINTENANCE, POSSIBLY RESULTING IN FIRE, ELECTRICAL SHOCK, CARBON MONOXIDE POISONING, EXPLOSION, PROPERTY DAMAGE, PERSONAL INJURY OR DEATH.

WARNING

PROPOSITION 65 WARNING: THIS PRODUCT CONTAINS CHEMICALS KNOWN TO THE STATE OF CALIFORNIA TO CAUSE CANCER, BIRTH DEFECTS OR OTHER REPRODUCTIVE HARM.

DO NOT DESTROY THIS MANUAL. PLEASE READ CAREFULLY AND KEEP IN A SAFE PLACE FOR FUTURE REFERENCE BY A SERVICEMAN.

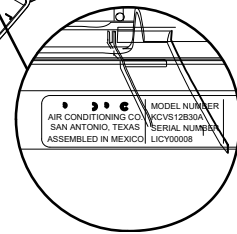
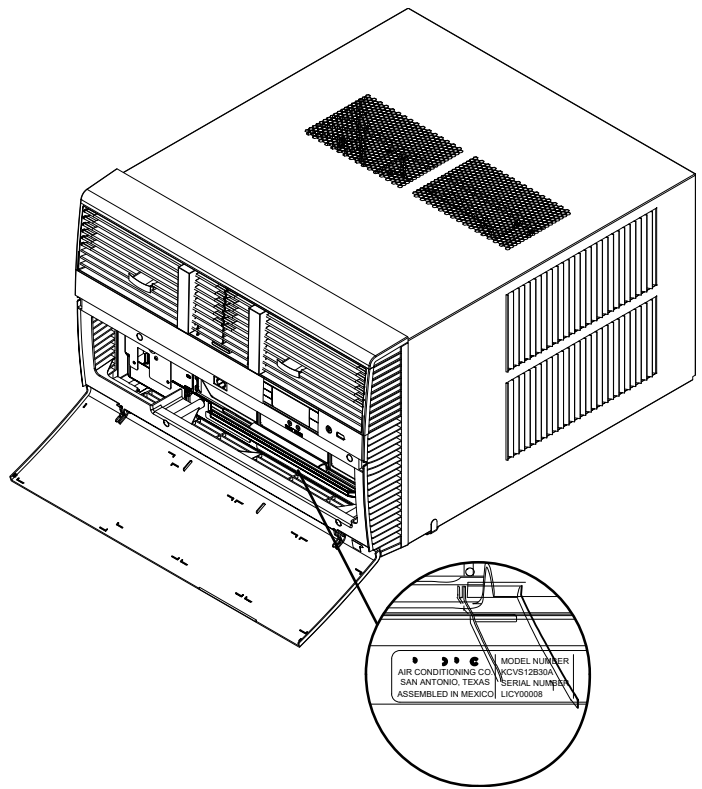

Model Nameplate Location

Register your Air Conditioner

Model information can be found on the name plate. Please complete and mail the owner registration card furnished with this product, or register online at www.friedrich.com.

For your future convenience, record the model information in Section R, information for the owner.

A. IMPORTANT SAFETY AND GENERAL INFORMATION	3	C.6 Cord Routing Change	26
A.1 Introduction	3	C.7 Install Filter	28
A.2 • Safety Symbols	3	E. ELECTRICAL	29
A.3 • Safety Warnings	4	E.1 Electrical Safety Information	29
A.4.1 Unpacking Instructions.....	5	J. STARTUP AND OPERATION.....	30
(Small and Medium Chassis)	5	J.1 Final Inspection	30
A.4.2 Unpacking Instructions.....	5	J.2 Air Flow Selection and Adjustment	30
(Large Chassis).....	5	J.3 Control Panel Operation.....	31
A.5 Importance of a Quality Installation.....	6	J.4 Remote Control Operation	33
A.6 Packing List	7	J.5 Start-up.....	33
B. SPECIFICATIONS	8	L. WIFI.....	33
B.1 Product Data.....	8	M. TROUBLESHOOTING.....	34
B.2 Model Identification Guide	8	M.1. Troubleshooting Tips	34
B.3 Outdoor Use.....	8	M.2 Diagnostic Codes	35
C. INSTALLATION OF THE UNIT.....	9	P. Appendixes	36
C.1 Pre-Installation Checkpoints.....	9	P.1 Accessories and Options	36
C.2 Tools Required	9	R. INFORMATION FOR THE OWNER.....	37
C.3. Choosing a Location.....	9	R.1 Room air conditioner unit performance test data sheet....	37
C.4 Window Installation	10	R.2 Routine Maintenance.....	37
C.5 Thru-the Wall Installation.....	19		

A. IMPORTANT SAFETY AND GENERAL INFORMATION

A.1 Introduction

This booklet contains the installation and operating instructions for your Air Conditioning unit. There are some precautions that should be taken to ensure proper operation. Improper installation can result in unsatisfactory operation or dangerous conditions.

Read this booklet and any instructions packaged with separate equipment required to make up the system prior to installation. Give this booklet to the owner and explain its provisions. The owner should retain this booklet for future reference.

A.2 · Safety Symbols

SAFETY IS IMPORTANT

We have provided many important safety messages in this manual and on your appliance. Always read and obey all safety messages.



This is a safety Alert symbol. This symbol alerts you to potential hazards that may harm you and could potentially lead to death.

All safety messages will tell you what the potential hazard is, tell you how to reduce the chance of injury, and tell you what may happen if the instructions are not followed.

All safety messages will follow the safety alert symbol with the word "WARNING" or "CAUTION". These words mean:



WARNING

Indicates a hazard which, if not avoided, can result in severe personal injury or death and damage to product or other property.



CAUTION

Indicates a hazard which, if not avoided, can result in personal injury and damage to product or other property.

NOTICE

Indicates property damage can occur if instructions are not followed.



This symbol indicates that this appliance uses a flammable refrigerant. If the refrigerant is leaked and is exposed to an external ignition source, there is a risk of fire.



This symbol indicates that the Operation Manual should be read carefully.



This symbol indicates that service personnel should be handling this equipment with reference to the installation manual.



This symbol indicates that information is available such as the Installation and Operation manual, or the Service Manual.

A. IMPORTANT SAFETY AND GENERAL INFORMATION

A.3 · Safety Warnings

⚠️ WARNING: The manufacturer's warranty does not cover any damage or defect to the air conditioner caused by the attachment or use of any components, accessories or devices (other than those authorized by the manufacturer) into, onto or in conjunction with the air conditioner. You should be aware that the use of unauthorized components, accessories or devices may adversely affect the operation of the air conditioner and may also endanger life and property. The manufacturer disclaims any responsibility for such loss or injury resulting from the use of such unauthorized components, accessories or devices.

⚠️ WARNING: This appliance is not intended for use by persons (Including children) with reduced physical, sensory or mental capabilities, or lack of experience and knowledge, unless they have been given supervision or instruction concerning use of the appliance by a person responsible for their safety.

Children should be supervised to ensure that they do not play with the appliance.

⚠️ WARNING: The maximum altitude for this appliance is 2,000 meters(6,562 feet).

Do not use above 2,000 meters(6,562 feet).

⚠️ WARNING: Electrical Shock Hazard

Disconnect all power to the unit before starting maintenance. All electrical connections and wiring MUST be installed by a qualified electrician and conform to the National Code and all local codes which have jurisdiction. Failure to do so can result in property damage, severe electrical shock or death.



⚠️ WARNING: Read Installation Manual

Read this manual thoroughly prior to equipment installation or operation. It is the installer's responsibility to properly apply and install the equipment. Installation must be in conformance with the NFPA 70-2023 national electric code or current edition, International Mechanic code 2021 or current edition, and any other local or national codes.



⚠️ WARNING: Safety First

Do not remove, disable, or bypass this unit's safety devices. Doing so may cause fire, injuries, or death.

⚠️ WARNING: This Product uses R-32 Refrigerant

Do not use means to accelerate the defrosting process or to clean, other than those recommended by the manufacturer.

The appliance shall be stored in a room without continuously operating ignition sources (for example: open flames, an operating gas appliance or an operating electric heater).

Do not pierce or burn.

Be aware that refrigerants may not contain an odor.



⚠️ WARNING: Refrigeration System under High pressure

Do not puncture, heat, expose to flame or incinerate. Only certified refrigeration technicians should service this equipment. R32 systems operate at higher pressures than R22 equipment. Appropriate safe service and handling practices must be used.

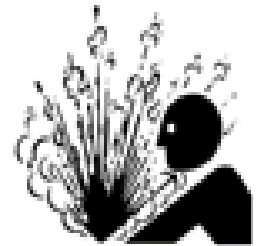

⚠️ CAUTION: Do Not Operate Equipment During Active Stages Of Construction

To ensure proper operation, Friedrich requires that all equipment is not operated during active construction phases. This includes active stages of completing framing, drywalling, spackling, sanding, painting, flooring, and moulding in the equipment's designated conditioning space. The use of this equipment during construction could result in premature failure of the components and/or system and is in violation of our standard warranty guidelines. The operation of newly installed equipment during construction will accelerate the commencement and/or termination of the warranty period.

⚠️ WARNING: Keep all air circulation and ventilation openings free from obstruction.

⚠️ WARNING: The unit should not be in contact with any equipment that will transmit vibration to the unit. Any excessive vibration or pulsation to the unit could result in damage to the refrigerant tubing.

A. IMPORTANT SAFETY AND GENERAL INFORMATION

A.4.1 Unpacking Instructions (Small and Medium Chassis)

- STEP 1. Cut all 4 packing straps.
- STEP 2. Remove wooden shipping bar dividers.
- STEP 3. Remove top foam pads.
- STEP 4. Slowly remove outer box, careful not to loosen decorative front.
- STEP 5. Slide the front forward.
- STEP 6. Carefully lift decorative front box from foam front support.
- STEP 7. Remove decorative front and set safely aside.

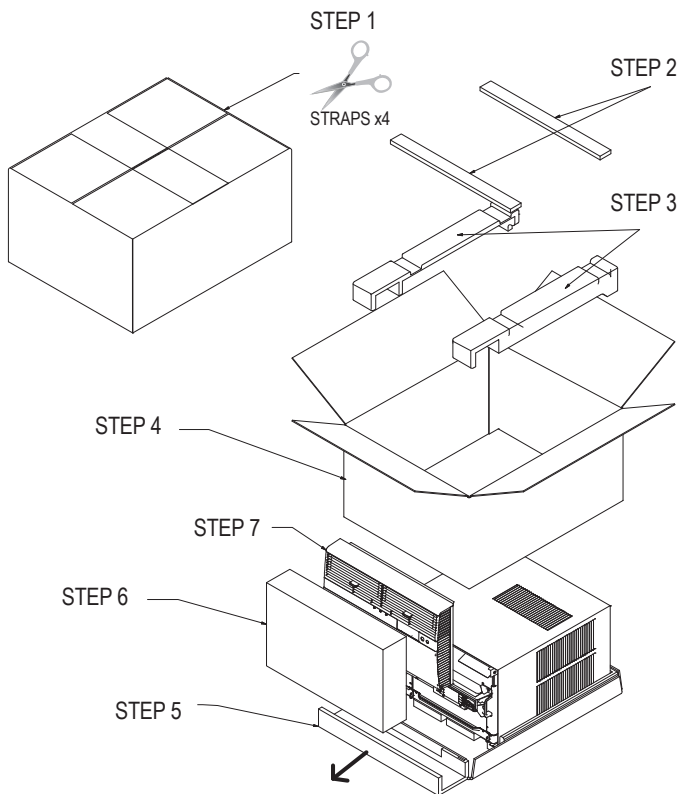

Figure A.4.1

A.4.2 Unpacking Instructions (Large Chassis)

- STEP 1. Cut all 4 packing straps.
- STEP 2. Slowly remove outer box, careful not to loosen decorative front.
- STEP 3. Remove top board assembly.
- STEP 4. Remove spacer.
- STEP 5. Remove shipping top.
- STEP 6. Remove Shipping Corners
- STEP 7. Remove decorative front, vent foam support blocks, and set safely aside.

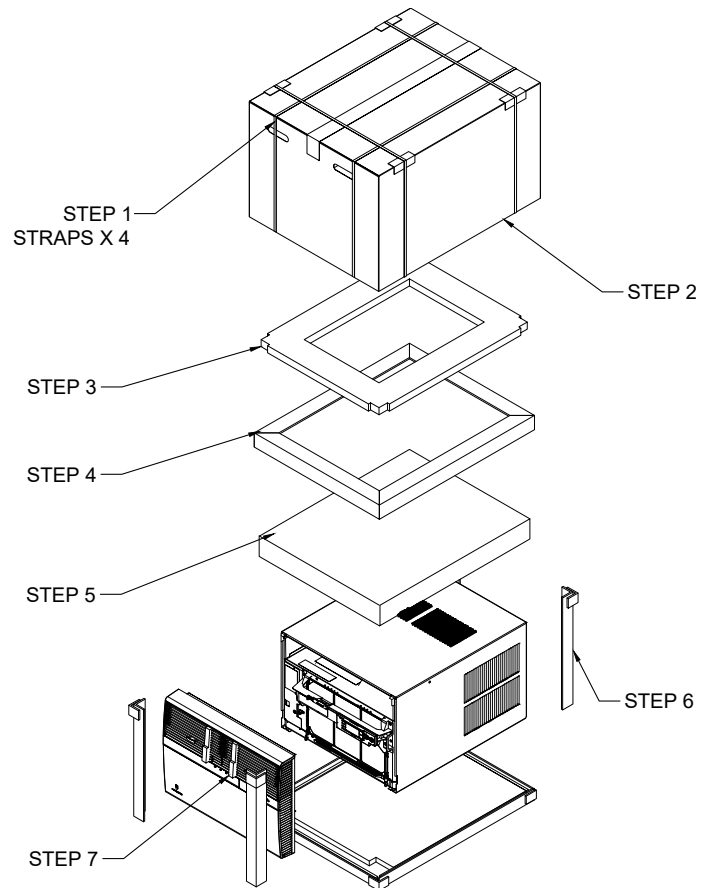

Figure A.4.2

A. IMPORTANT SAFETY AND GENERAL INFORMATION

A.5 Importance of a Quality Installation

Optimal system performance and longevity depend upon a quality and proper installation. Failure to properly install this unit could result in undesirable operation and subsequent faults and potential failures.

Carefully follow all guidelines listed in the manual and industry best practices. Conform to all local code requirements. Contact your local technical representative with any questions or concerns.

Upon receiving the unit, inspect it for any damage from shipment. Claims for damage, either shipping or concealed, should be filed immediately with the shipping company. **IMPORTANT:** Check the unit model number, Cooling size, electrical characteristics, and accessories to determine if they are correct.

⚠ WARNING: Check the unit power cord and make sure the cord is protected from wear, corrosion, excessive pressure, vibration, sharp edges, or any other adverse environmental effects. It is recommended that the cord is checked for any potential damage when filter maintenance is performed. If the supply cord is damaged, it must be replaced by the manufacturer, its service agent or similarly qualified persons in order to avoid a hazard.

⚠ WARNING: If the unit appears damaged, or if a refrigerant leak is suspected, do not install. Contact a licensed repair person to perform a leak check on the unit.



⚠ WARNING: Under no circumstances shall potential sources of ignition be used in the searching for or detection of refrigerant leaks. A halide torch (or any other detector using a naked flame) shall not be used. The following leak detection methods are deemed acceptable for all refrigerant systems. Electronic leak detectors may be used to detect refrigerant leaks but, in the case of **FLAMMABLE REFRIGERANTS**, the sensitivity may not be adequate, or may need re-calibration. (Detection equipment shall be calibrated in a refrigerant-free area.) Ensure that the detector is not a potential source of ignition and is suitable for the refrigerant used. Leak detection equipment shall be set at a percentage of the LFL.

⚠ WARNING: Service of this product (aside from filter maintenance) shall only be performed by trained service personnel. This includes:

Opening of any tubing or refrigerant circuit work

Opening of any sealed components

Enclosures beyond the hinged door for filter cleaning

Scan this QR code to be linked to the Friedrich professional support page where you can locate the Service Manual.



A. IMPORTANT SAFETY AND GENERAL INFORMATION

A.6 Packing List

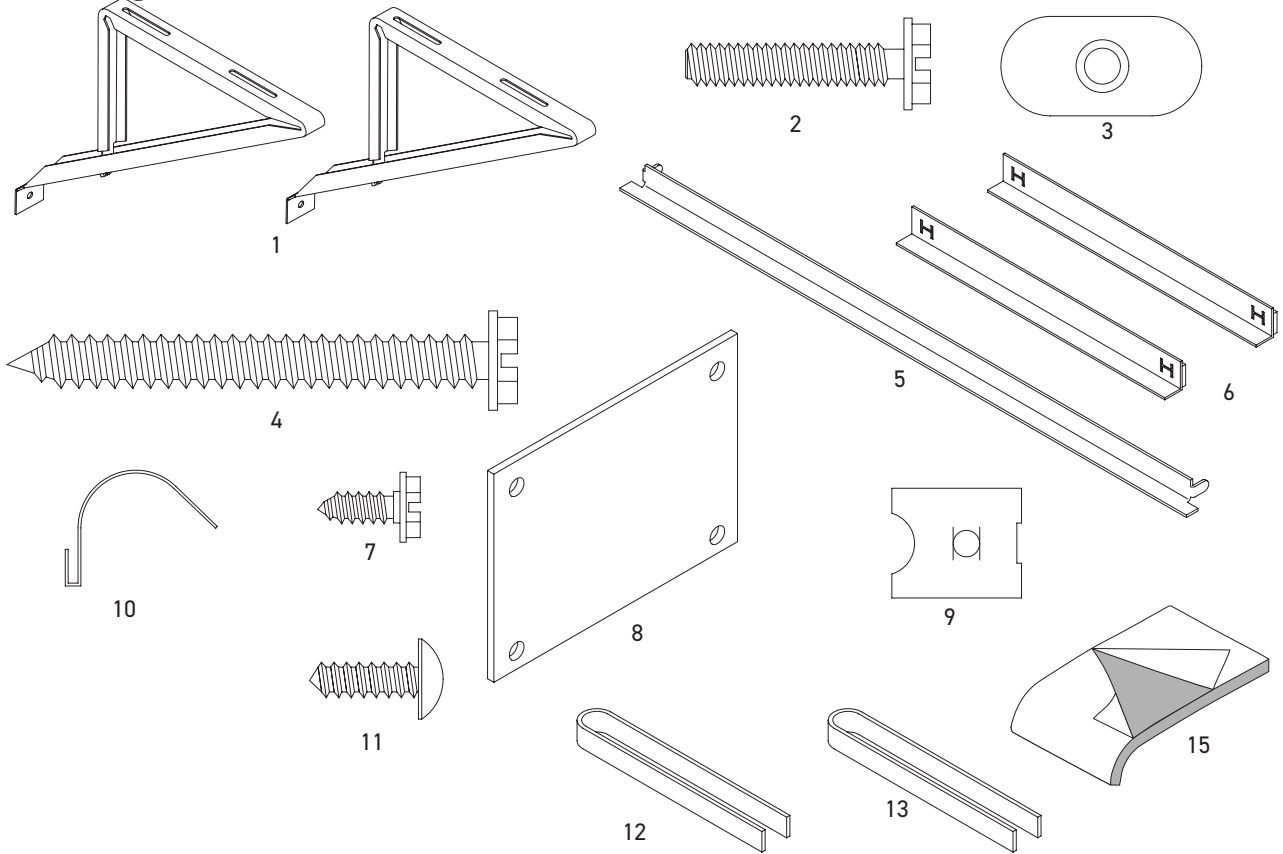

Window Mount Installation Hardware		
ITEM NO	DESCRIPTION	QTY.
WINGBOARD MOUNTING PARTS		
8	WINGBOARD (MASONITE)	1
9	"J" TYPE SPEED NUT	4
10	WINGBOARD CLIP (SPRING STEEL)	4
11	SCREW, #8 x 1/2" PHILLIPS TRUSS HD.	4
WINDOW SEALING		
12	WINDOW SEAL GASKET (DARK FOAM)	1
13	CHASSIS SEAL GASKET (LIGHT FOAM)	1
SHELL MOUNTING PARTS		
1	SUPPORT BRACKET	2
2	SCREW, 10-24 x 1" HEX HEAD	4
3	10-24 FLAT NUT	4
4	SCREW, SHEET METAL #12 x 2"	7
WINGBOARD ANGLE MOUNTING		
5	BRACKET, TOP	1
6	BRACKET, SIDE	2
7	SCREW, SHEET METAL #8 x 3/8"	2

Thru-the-Wall Installation Hardware		
ITEM NO	DESCRIPTION	QTY.
MOUNTING PARTS		
4	SCREW, SHEET METAL #12A x 2"	7
13	CHASSIS SEAL GASKET (LIGHT FOAM)	1

Additional Parts		
ITEM NO	DESCRIPTION	QTY.
MOUNTING PARTS		
15	R1 Insulation Panel	1
16	Remote Control Registration Card	1

NOTE: Kühl + models do not come with window mounting components. When mounting a Kühl + model, a window installation kit must be purchased separately.

Figure A.6 (Packing List)

B. SPECIFICATIONS

B.1 Product Data

The new Kühl gives you a variety of options for control, programming, and scheduling including wireless capabilities.

Wireless Programming and Control:

Friedrich Connect allows you to conveniently control, program, and monitor your air conditioning unit remotely from a smartphone or computer.

Pre-Programmed Timer Options:

Your unit's digital control comes equipped with a 24-hour timer.

24-Hour Timer

The 24-hour timer allows you to set 2 temperature changes at pre-set times or a unit control panel.

Customizable Programming Options:

Customizable timers, with up to four temperature adjustments per day, can be set using Friedrich Connect for one or multiple units.

See www.friedrich.com for complete details on Friedrich Connect.

B.3 Outdoor Use

The only section of this air conditioner acceptable for outdoor use is designated by the area in the image below. To ensure the protection of parts not acceptable for outdoor use please follow the installation instructions as shown in this document. Please note that junction and electrical boxes are not acceptable for outdoor use.

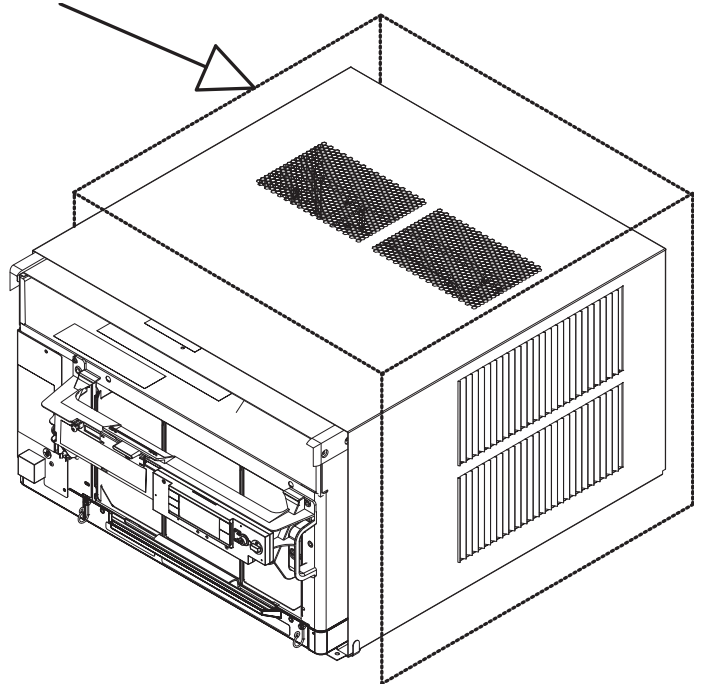

B.2 Model Identification Guide

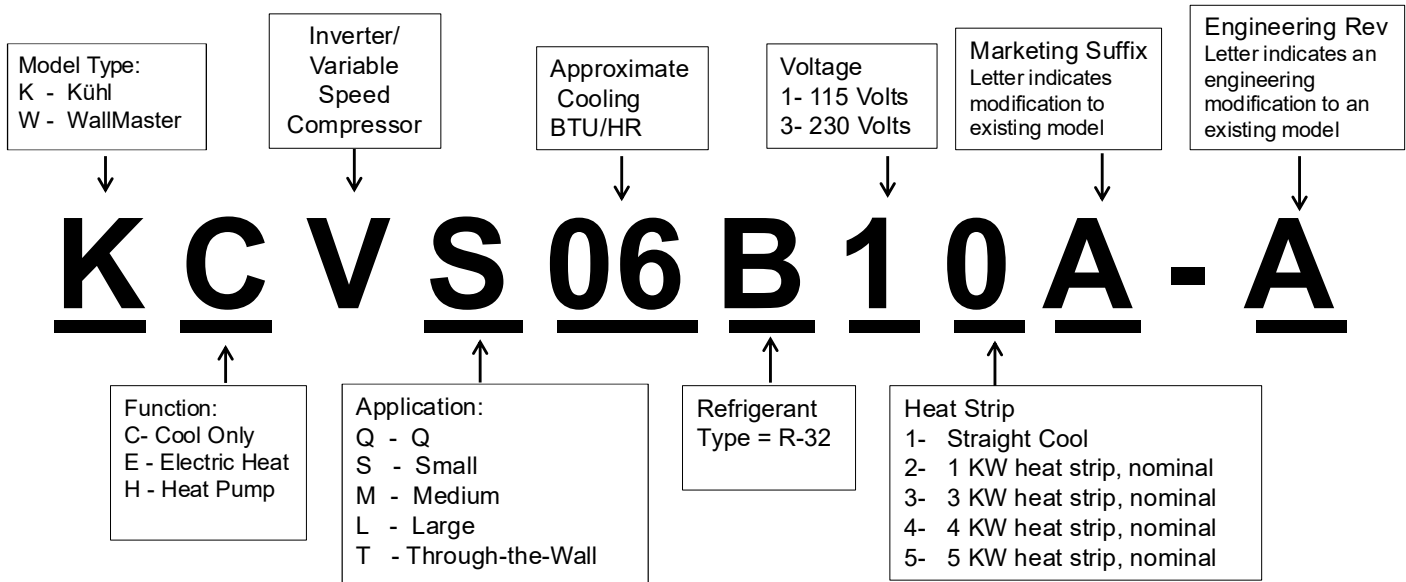

C. INSTALLATION OF THE UNIT

C.1 Pre-Installation Checkpoints

Before attempting any installation, carefully consider the following points:

- Clearances and provision for servicing. Install this unit in accordance with local and national standards. Any and all work must be done by authorized personnel.
- **IMPORTANT:** Before you begin the actual installation of your air conditioner, check your local electrical codes and the information below. Your air conditioner must be connected to a power source with the same alternating current (A.C.) voltage and amperage as marked on the name plate located on the chassis. Only A.C. can be used. Direct Current (D.C.) cannot be used.
- **CIRCUIT PROTECTION** – Use on single outlet circuit only. An overloaded circuit will invariably cause malfunction or failure of an air conditioner; therefore, it is necessary that the electrical protection is adequate. Due to momentary high current demand when the air conditioner starts, use a “TIME DELAY” fuse or a HACR type circuit breaker. Consult your dealer or power company if in doubt.
- Refer to the electrical name plate located on the air conditioner chassis (see Table E.1 to determine the correct fuse or circuit breaker amperage for your model.
- The power cord has a plug with a grounding prong and a matching receptacle is required.

C.2 Tools Required

⚠ WARNING	
	<p>Electrical Shock Hazard</p> <p>Make sure your electrical receptacle has the same configuration as your air conditioner's plug. If different, consult a Licensed Electrician.</p> <p>Do not use plug adapters. Do not use an extension cord. Do not remove ground prong.</p> <p>Always plug into a grounded 3 prong outlet. Failure to follow these instructions can result in death, fire, or electrical shock.</p>

- | | |
|-------------------------------------|----------------------------|
| 1. Power Drill | 10. Flat Head Screw Driver |
| 2. 5/32" Drill Bit | 11. Measuring Tape |
| 3. Gloves | 12. Utility Knife |
| 4. Carpenters Level | |
| 5. 5/16" Wrench | |
| 6. 1/4" Wrench | |
| 7. #2 Phillips Screw Driver | |
| 8. Putty Knife or (wood stir stick) | |
| 9. 1/4" Nut Driver | |

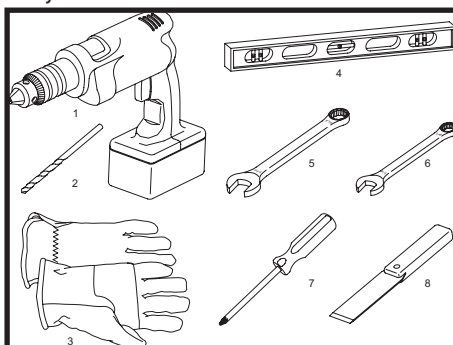

Figure C.2 (Tools)

C.3. Choosing a Location Installation Clearances

Improper installation of the Air Conditioner can cause poor performance and premature wear of the unit.

Ensure that the KUHL unit is installed with proper clearances as described below.

Ensure no obstructions or enclosures are within clearances limits to allow for proper airflow.

Ensure no open flames, or surfaces that will exceed 1000 degrees Fahrenheit are within clearances limits.

⚠ WARNING	
	<p>Refrigeration System Under High Pressure</p> <p>Do not puncture, heat, expose to flame or incinerate. Only certified refrigeration technicians should service this equipment. R410A and R32 systems operate at higher pressures than R22 equipment. Appropriate safe service and handling practices must be used. Only use gauge sets designed for use with R410A or R32. Do not use standard R22 gauge sets..</p>

Clearances

Top and Bottom of Unit - One (1) foot

Sides of Unit - One (1) foot

Front of Unit - Three (3) feet

Rear of Unit - Three (3) feet

⚠ CAUTION	
	<p>Moving Parts Hazard</p> <p>Do not operate unit out of sleeve or with front grille removed. Do not place hands in blower or fan blade areas. Failure to do so can result in serious injury</p>

⚠ CAUTION	
	<p>Excessive Weight Hazard</p> <p>Use two or more people when installing your air conditioner. Failure to do so can result in back or other injury.</p>

C. INSTALLATION OF THE UNIT



C.4 Window Installation

NOTE: Hardware used during the installation is illustrated in section A. 6

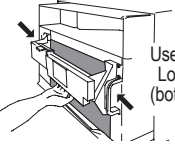
STEP 1. Remove the chassis EntryGard™ retainer by removing the far right screw (see Figure C.4.1). Save this screw to reattach the chassis retainer after installation (Step 12). Also, remove and discard the two retainer screws and washer located at the rear of the unit (see Figure C.4.1).

 CAUTION	
 <p>Use Handle Locations (both sides)</p>	<p>Handle Use</p> <p>Use handle on both sides to pull unit from sleeve.</p> <p>Do not push, pull, or lift from center of support.</p>

STEP 2. Hold the cabinet stationary. Then, use the hand grips on both ends of the control unit support bracket to pull the chassis out of the cabinet (see Figure C.4.2).

 WARNING	
	<p>Fire Hazard</p> <p>A2L refrigerant is classified as mildly flammable. Do not install unit next open flame sources, or surfaces that will exceed 1200 degrees fahrenheit.</p>
<p>Refrigerant Safety Group A2L</p>	

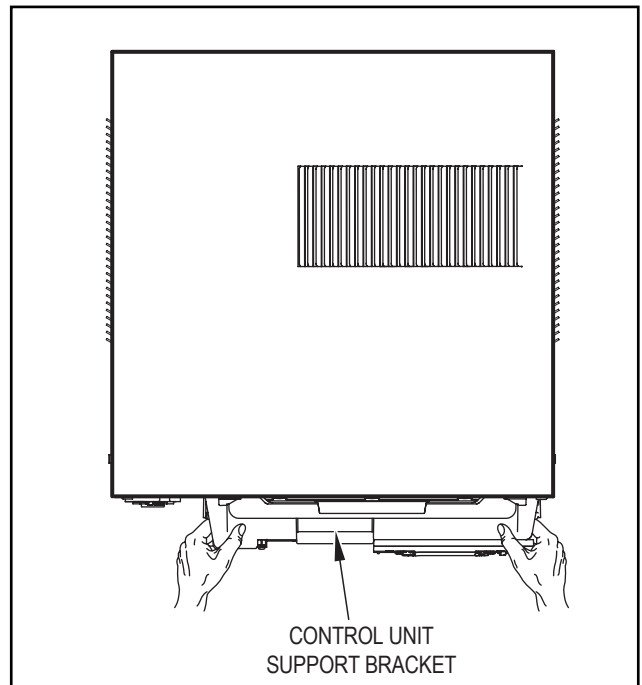

Figure C.4.2

STEP 3. Anchor the brackets (Item 6) by engaging the tabs of the lower sill plate (C.4.4 Detail 1) with the loops of the side angle. Engage the tabs of the top angle (Item 5) with the top loops of the side angle (C.4.4 Detail 2). Install two (2) screws (Item 7) to secure the top angle tabs and the side angle to cabinet (see Figure C.4.4 Detail 2).

NOTE: It may be helpful to start the screw before fully engaging the tabs so that the taper hole aligns with the screw.

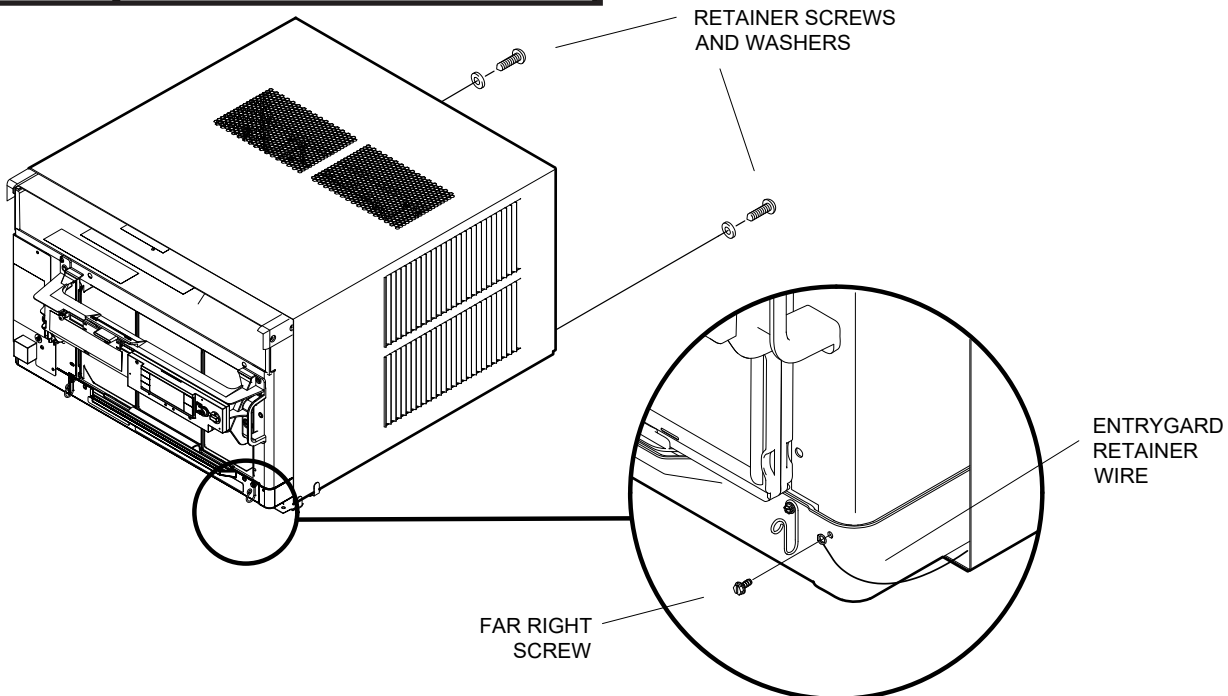

Figure C.4.1

C. INSTALLATION OF THE UNIT

C.4 Window Installation (Continued)

STEP 4. Check the window sill and frame to be sure they are in good condition and functioning.

STEP 5. CABINET MOUNTING – Raise the lower window $\frac{1}{4}$ " more than the height of the cabinet. Carefully slide the cabinet through the opening until the lower sill plate channel rests behind the window sill and the top angle rests against the window (see Figure C.4.5). Center the cabinet within the opening. Drill three (3) $\frac{5}{32}$ " diameter pilot holes into window sill using the holes in the cabinet sill plate as a guide. Install three (3) #12 x 2" long screws (Item 4) (see Figure C.4.5).

STEP 6. OUTSIDE SUPPORT MOUNTING – Refer to Figures C.4.6 and C.4.7 Assemble the support brackets (Item 1) to the bottom of the cabinet with four (4) 10-24 1" long screws (Item 2) and four 10-24 flat nuts (Item 3). Adjust the support brackets, using a combination of the elongated holes of the bracket and different hole locations in the cabinet, to bring the bottom support bracket pads in contact with the wall. A 1" x 4" or 2" x 4" SPACER SHOULD BE USED BETWEEN THE WALL AND SUPPORT THE BRACKETS WHEN INSTALLED ON ALUMINUM OR VINYL SIDING. Drill $\frac{5}{32}$ " diameter pilot holes and secure the brackets to the wall with two (2) 12A x 2" long screws (Item 4).

NOTE: DO NOT LEVEL the cabinet from front-to-back. Make sure there is approximately a $\frac{3}{8}$ " to $\frac{1}{2}$ " slope ($\frac{1}{8}$ to $\frac{1}{4}$ bubble on level) toward the outside of the house.

Adjust the support brackets to provide an inside-to-outside slope for excess condensation drainage (refer to Standard Window Installation, Figures C.4.6 through C.4.8). Tighten all screws.

Alternate support method A: If you have a deep window sill which prevents you from mounting the brackets as shown in Figure C.4.8, try the following: Using the elongated holes and different hole locations in the cabinet, set the placement of the bracket to support the unit's weight (Figure C.4.9). Tighten all screws.

Alternate support method B: If the window ledge gap is narrow, try the following. Bend the bracket end tab flat. Cut the bracket in two (2) places as shown in Figure C.4.10. Bend the short piece so it will be vertical when installed. Adjust the placement as required. Tighten all screws.

STEP 8. Measure and cut the wingboard panels (fit with about $\frac{1}{8}$ " clearance) from the supplied Masonite (Item 8) to fit the space between the window side channels and cabinet (Figure C.4.11). Make sure you include the depth of the window channel.

NOTE: A good method to cut the wingboard panel is to score both sides with a utility knife and then snap it.

NOTICE



For YOUR security and safety, YOU must provide a means of preventing the upper part of the window from opening.

STEP 9. To assemble the wingboard panels, push on the "J" type speed nuts (Item 9) and spring steel clips (Item 10) (see Figure C.4.12). Secure each panel with two (2) screws (Item 11). (see Figure C.4.13)

NOTE: The spring steel clips will engage with the runners of the window jam.

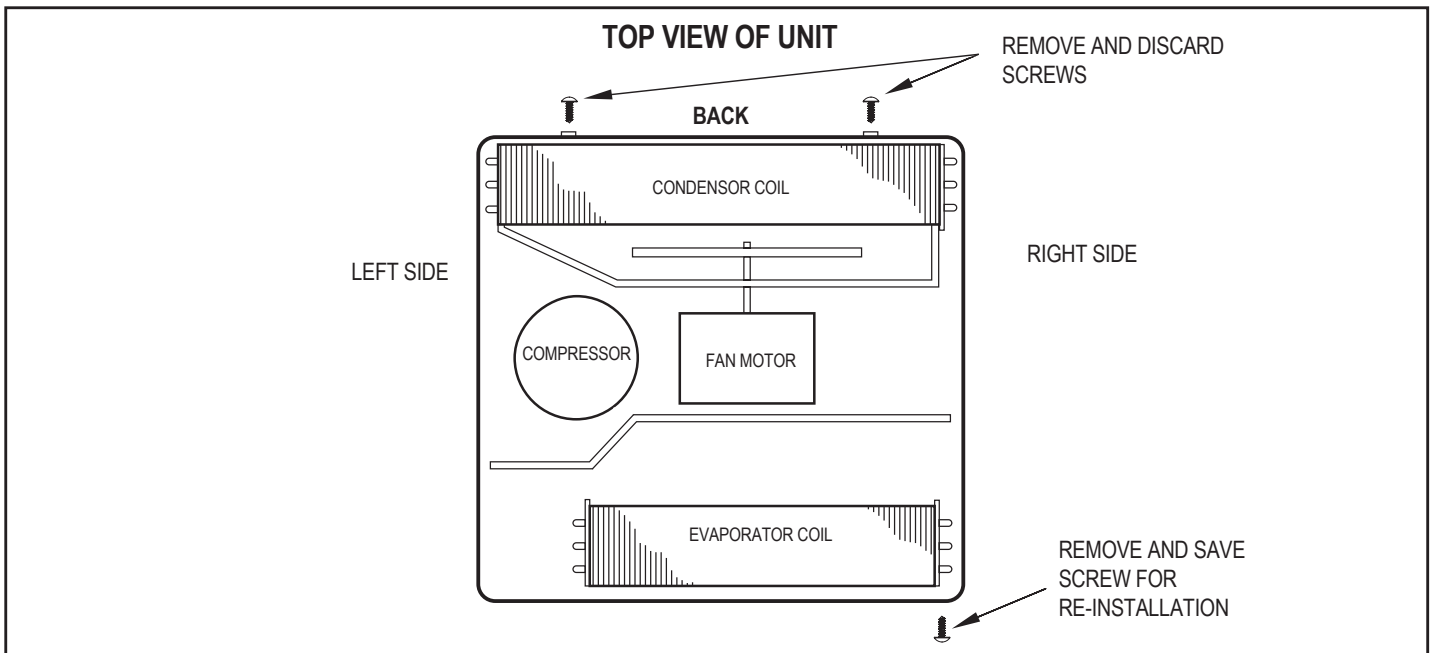

Figure C.4.3

C. INSTALLATION OF THE UNIT

C.4 Window Installation (Continued)

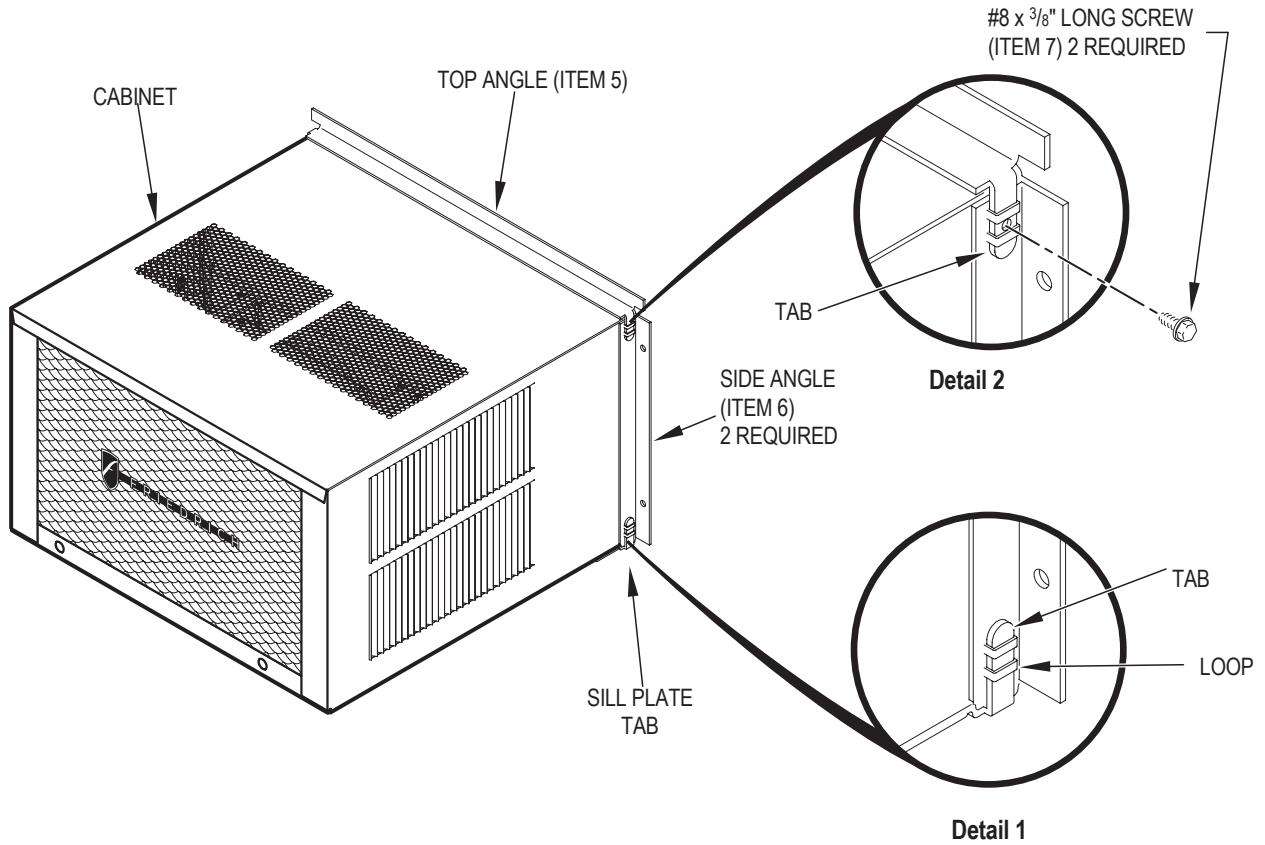

Figure C.4.4

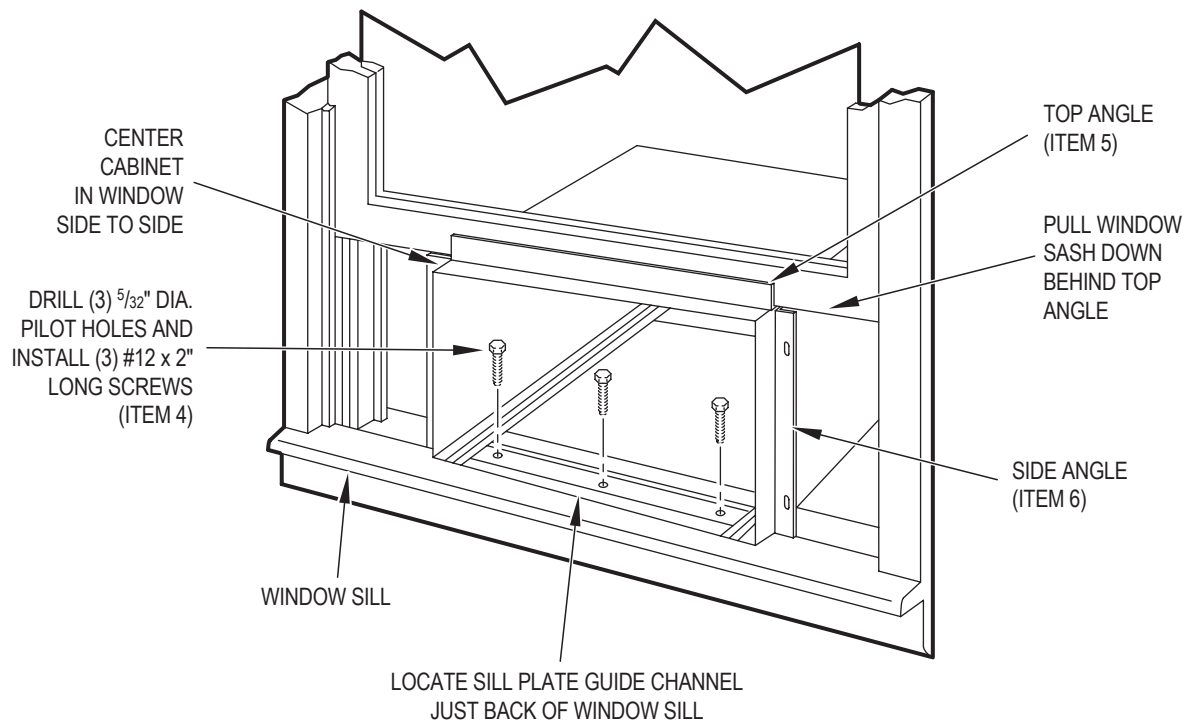

Figure C.4.5

C. INSTALLATION OF THE UNIT

C.4 Window Installation (Continued)

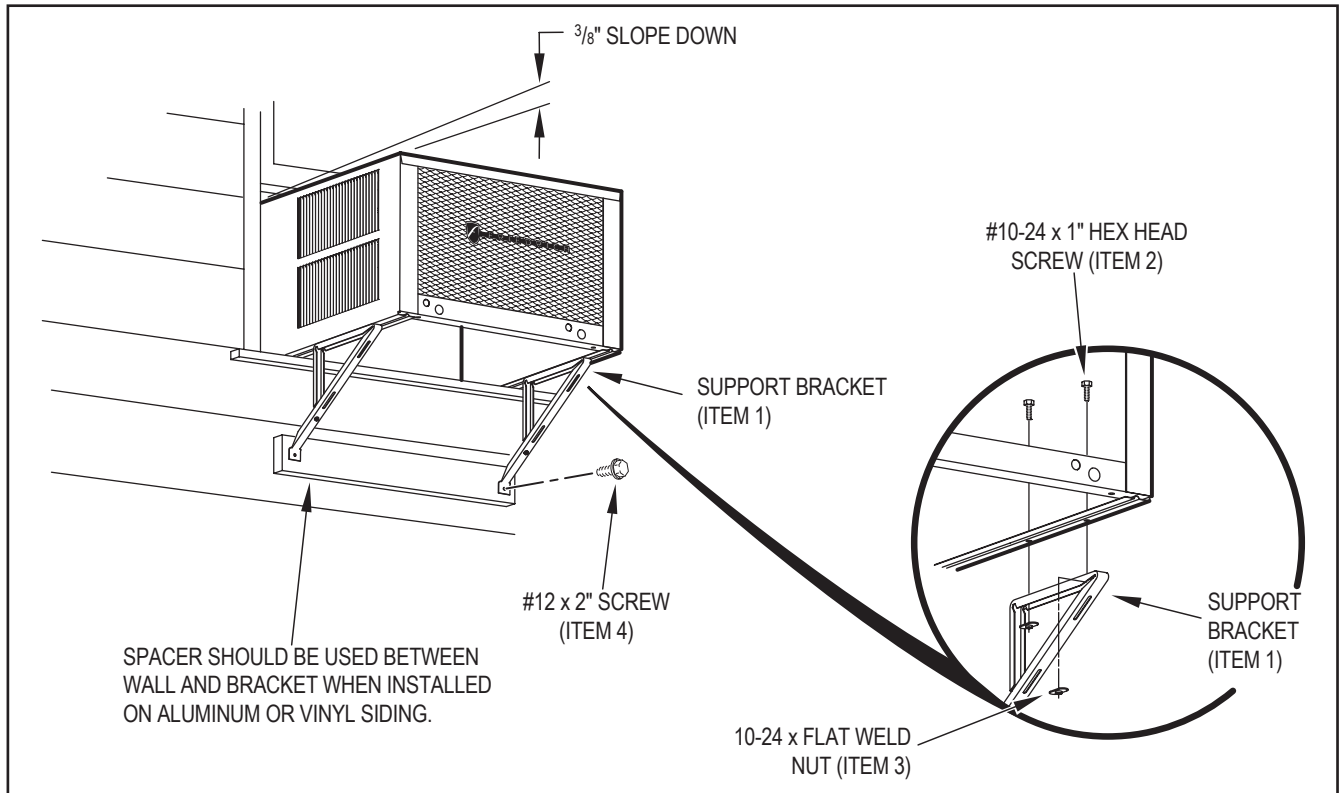

Figure C.4.6

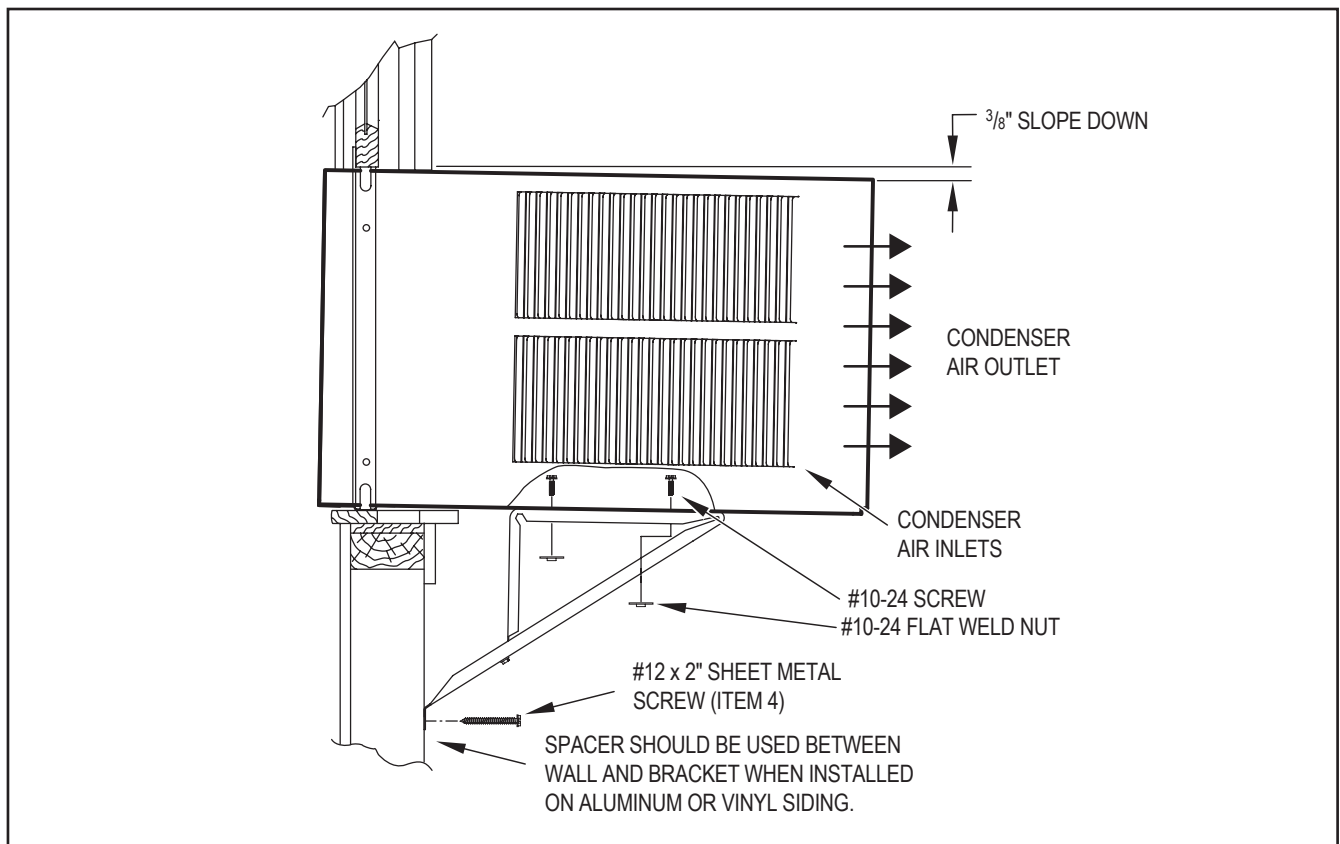

Figure C.4.7

C. INSTALLATION OF THE UNIT

C.4 Window Installation (Continued)

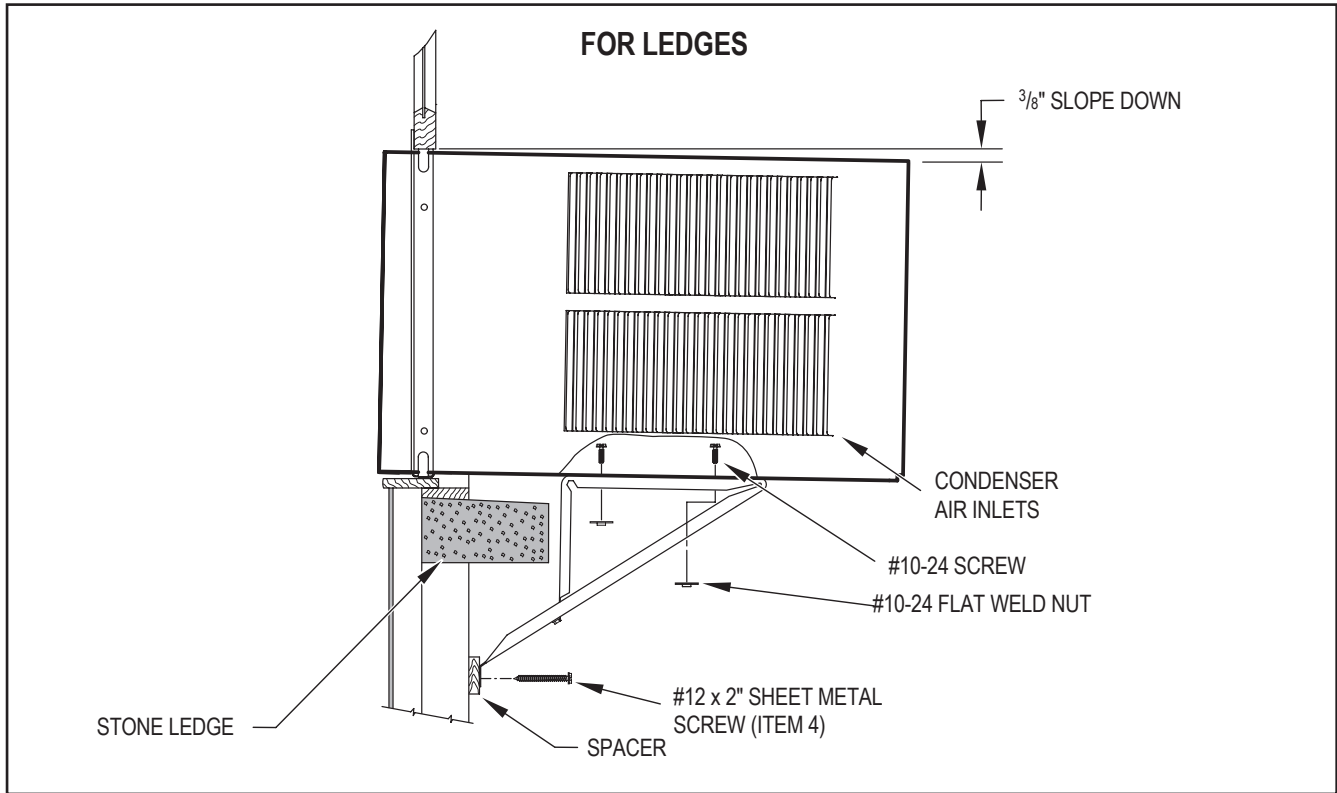

Figure C.4.8

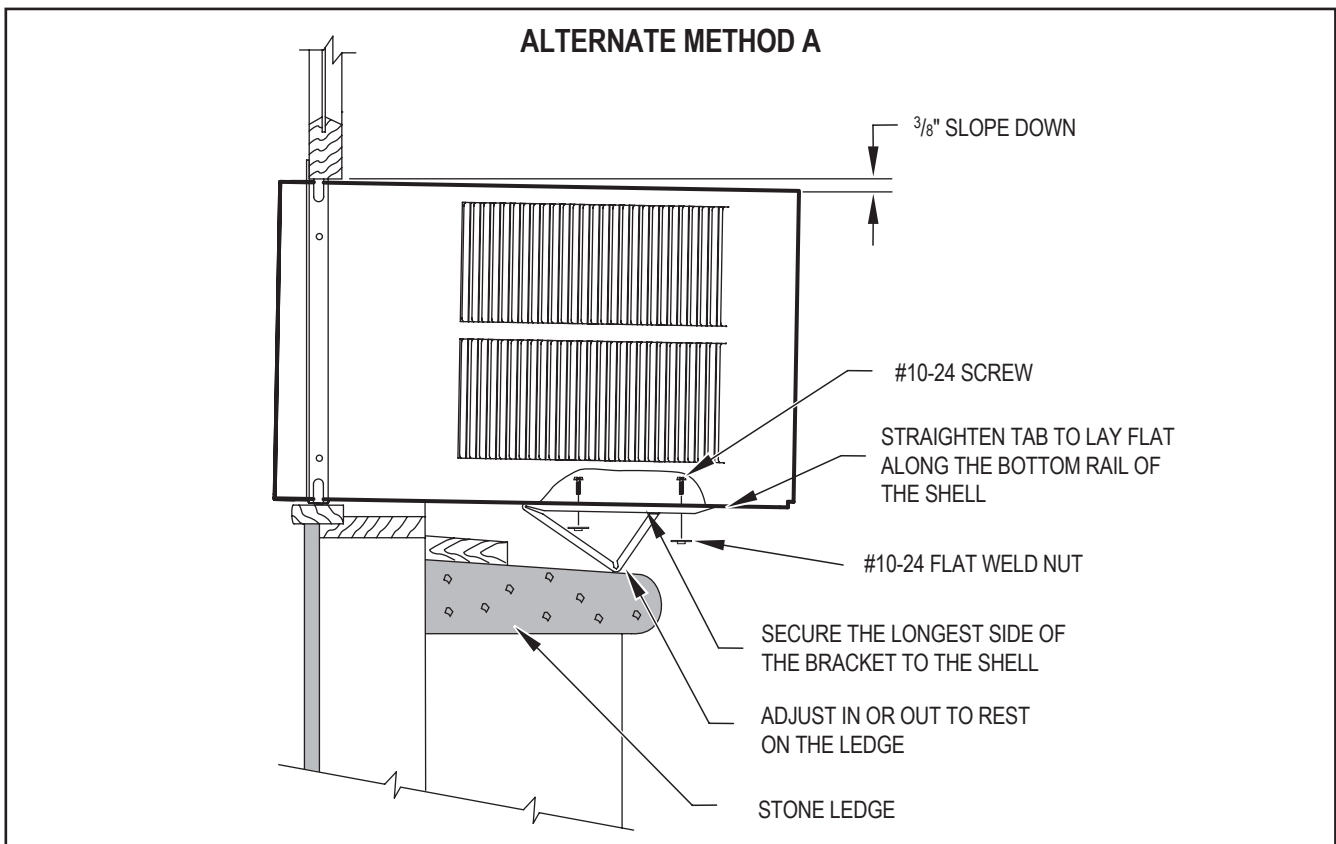

Figure C.4.9

C. INSTALLATION OF THE UNIT

C.4 Window Installation (Continued)

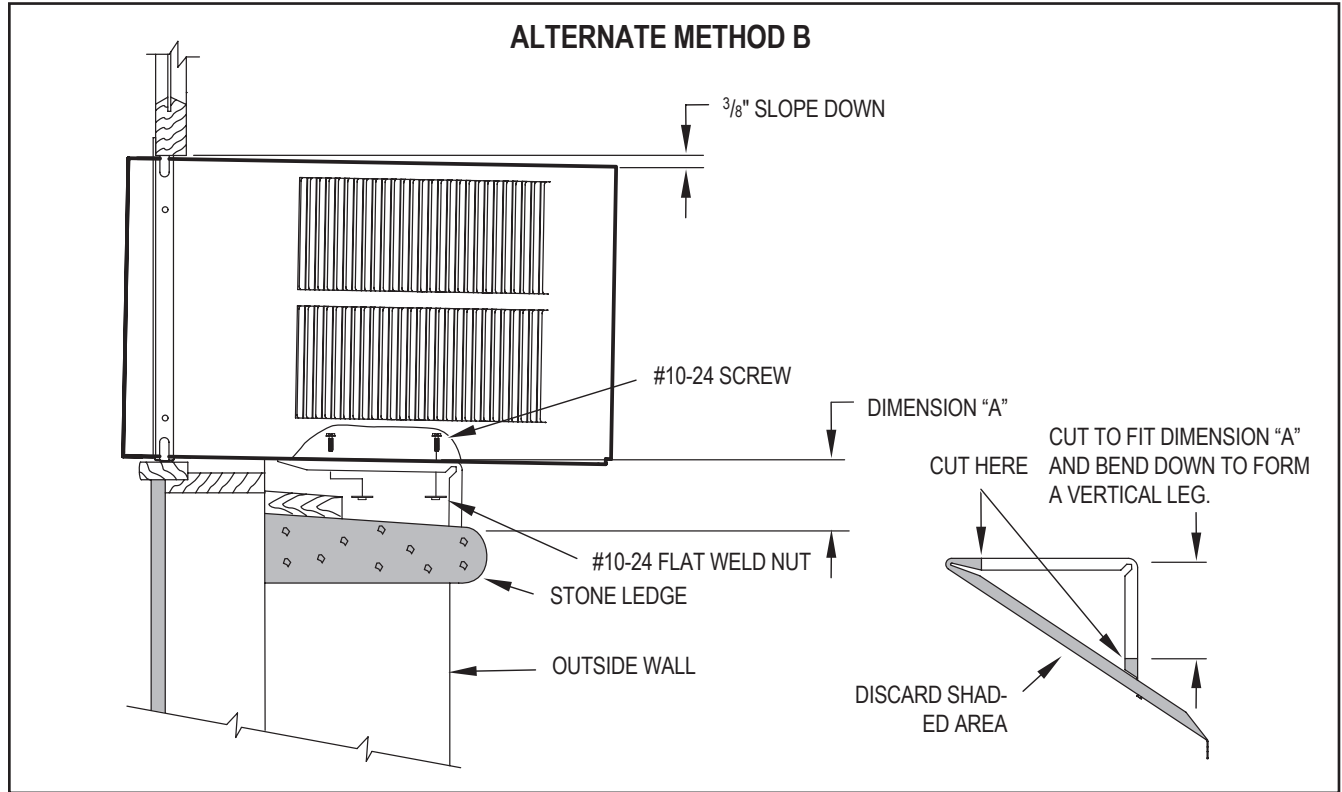

Figure C.4.10

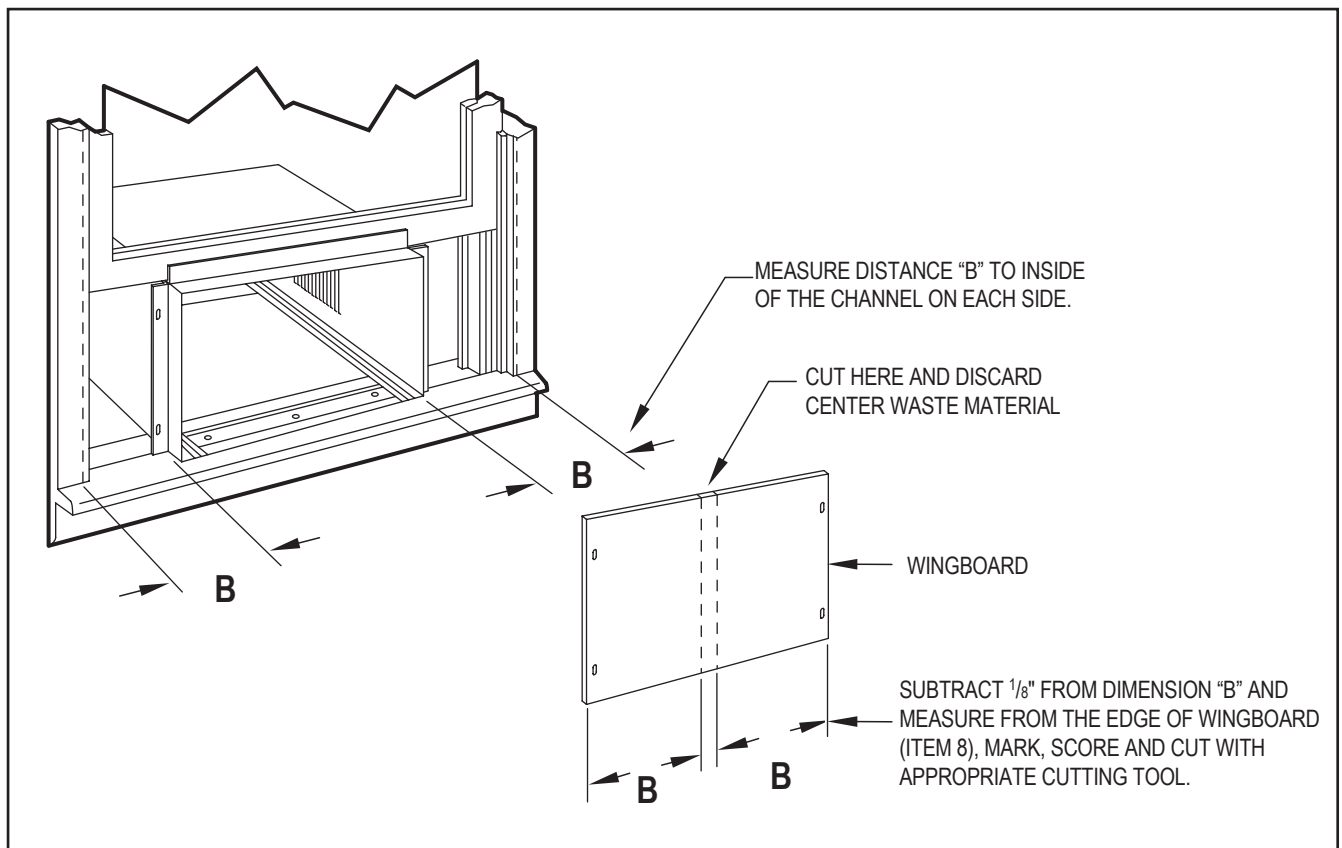



Figure C.4.11

C. INSTALLATION OF THE UNIT

C.4 Window Installation (Continued)

⚠ WARNING	
	<p>Falling Object Hazard</p> <p>Not following Installation Instructions for mounting your air conditioner can result in property damage, injury, or death.</p>

⚠ CAUTION	
	<p>Cut/Sever</p> <p>Although great care has been taken to minimize sharp edges in the construction of your unit, use gloves or other hand protection when handling unit</p> <p>Failure to do so can result in minor to moderate personal injury.</p>

STEP 10. INSTALL THE R1 INSULATION PANEL – To minimize air leaks and ensure optimal insulation, install the included R1 insulation panel (14 in parts list) (see Figure C.4.14).

First, measure the width from one side of the cabinet/sleeve (covering the side angles where the wingboard was just secured) to the end of the wingboard (see Figure C.4.11).

Next, cut the R1 insulation panel to the measured width and remove protective cover, exposing adhesive on back panel (see Figure C.4.14).

Last, evenly apply the adhesive side of the panel across the entire height and width from side angle to wingboard panel (see Figure C.4.14).

Repeat the steps above for the other wingboard panel.

STEP 11. INSTALL THE WINDOW SEALING GASKETS – Measure and cut the dark foam window seal gasket (Item 12) and install it between the upper glass panel and the top part of the window sash (see Figure C.4.14).

STEP 12. Carefully team lift the chassis and set it into the cabinet. Slide the chassis stopping approximately 3" from full insertion. Insert the chassis seal gasket (Item 13) one inch deep between the chassis and the cabinet (see Figure C.4.15). A paint stir stick or ruler might be helpful here. Begin inserting the gasket at either bottom corner and go up the side, across the top, and down the opposite side. Then push the chassis all the way into the cabinet.

NOTE: If the chassis seal gasket is not installed or installed improperly, the operation of the unit will be negatively affected. Operational noise and outside noise will also be amplified.

STEP 13. Reattach the EntryGard™ chassis and EntryGard™ retainer wire with the same screw retained in Step 1 (see Figure C.4.1).

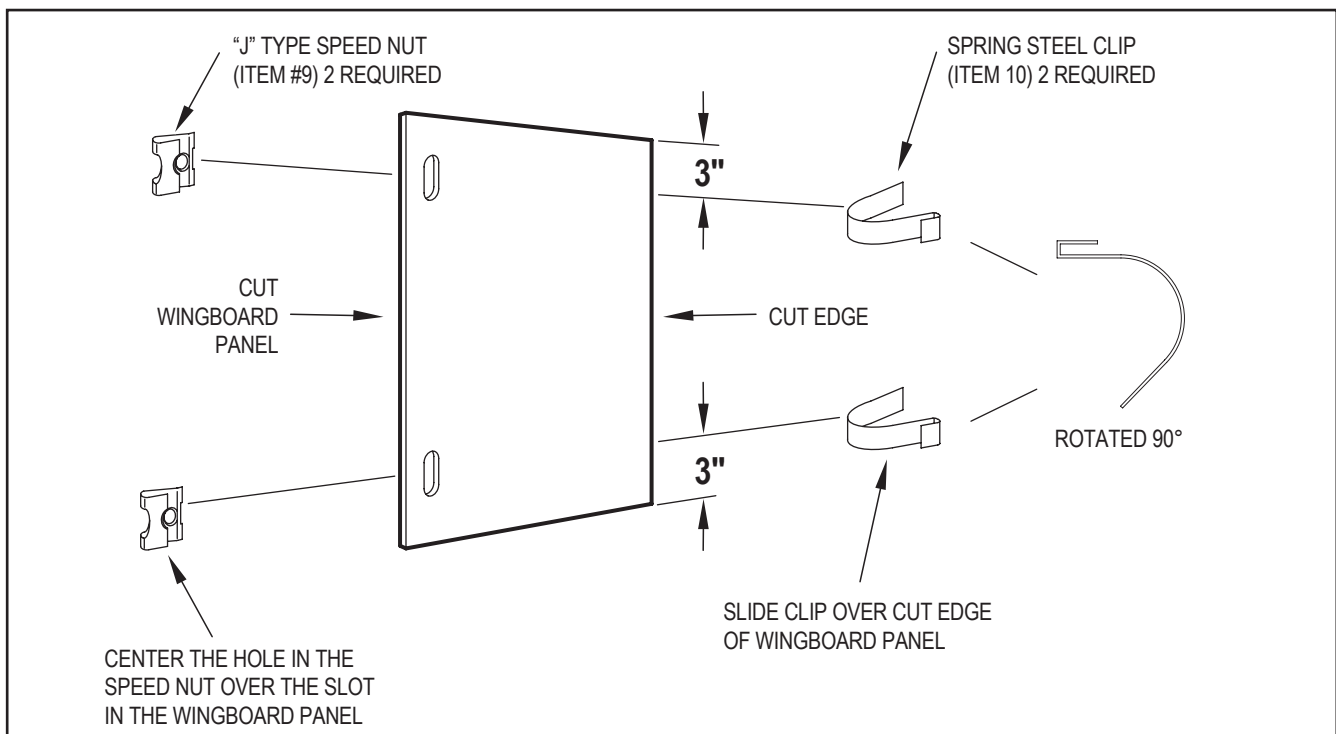

Figure C.4.12

C. INSTALLATION OF THE UNIT

C.4 Window Installation (Continued)

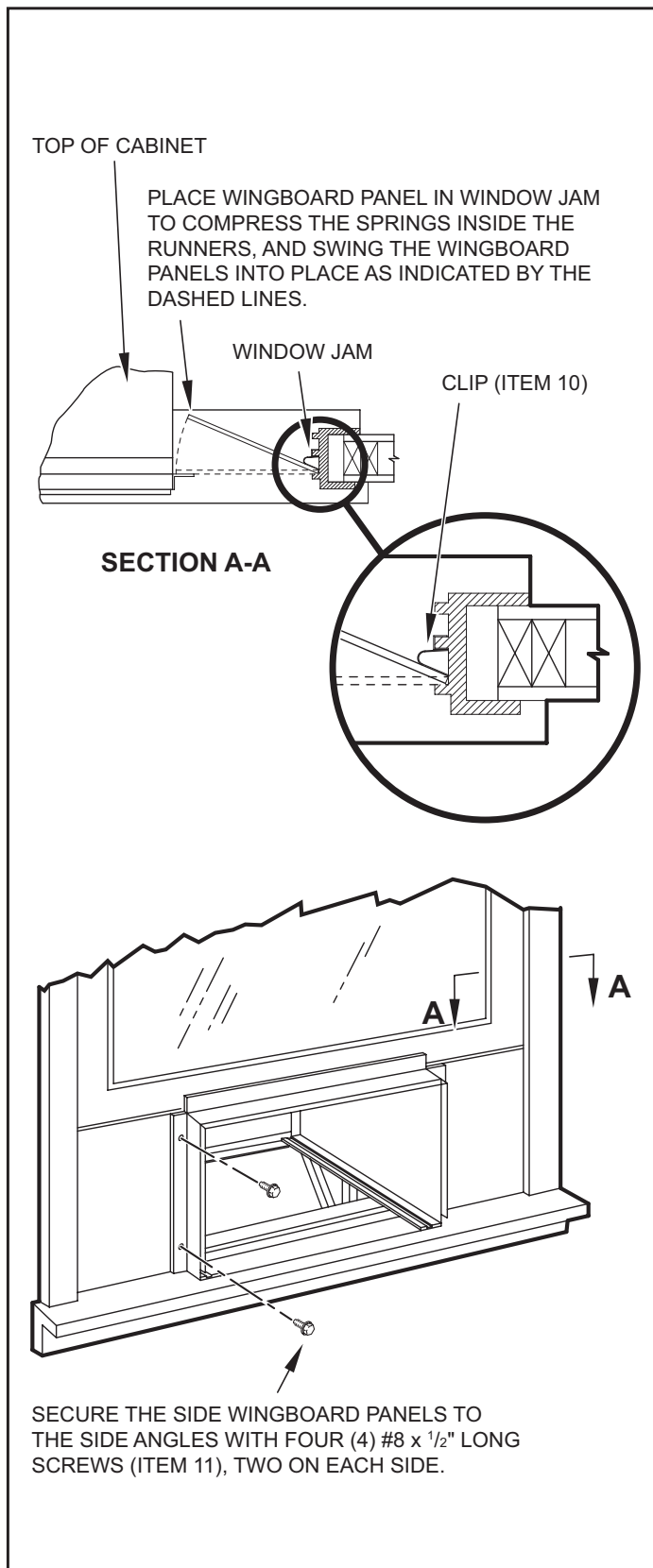

Figure C.4.13

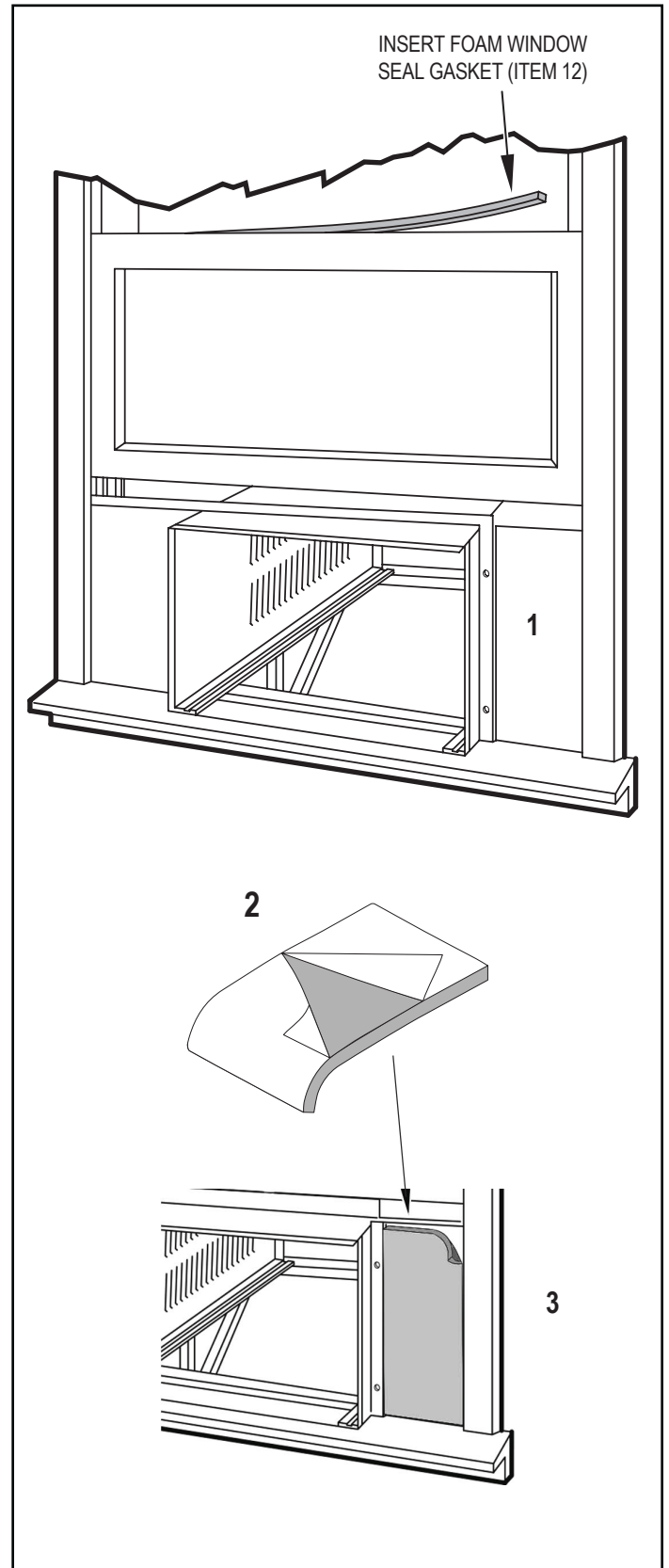

Figure C.4.14

C. INSTALLATION OF THE UNIT

C.4 Window Installation (Continued)

OPTIONAL: The factory assembles the supply cord so that it exits the left side of the unit at the bottom. At the consumer's discretion, pull the supply cord taut through the loops (refer to Cord Routing Change, Section C.6) and route the cord down.

STEP 14. To attach and prevent damage to the front grille, align the cord notch over the cord and center the fresh air lever, then align and tighten the four (4) captive screws as indicated by the arrows in Figure C.4.16. (preferred tool is a 1/4" nut driver) Before closing the front panel, be sure the filter is in place. Make sure curtains do not block the side air intakes.

STEP 15. Refer to the Control Panel Operation section for instructions.

You are now ready to control the comfort level of the room.

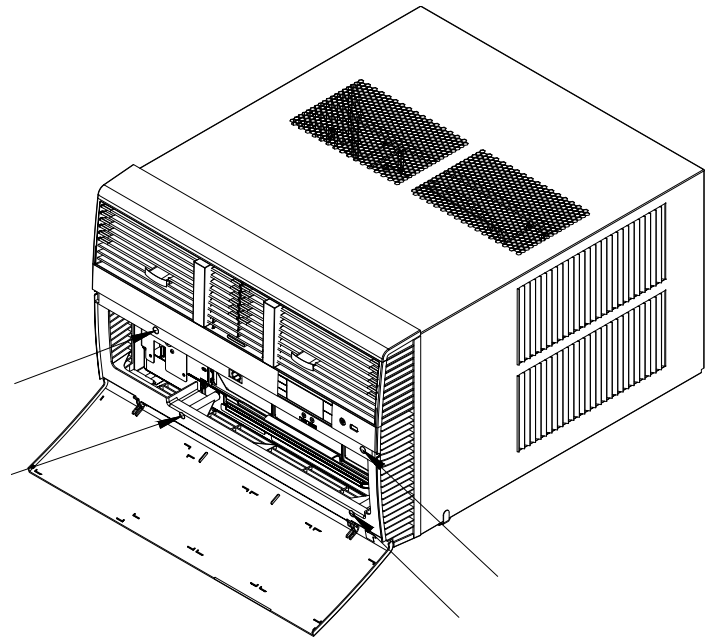

Figure C.4.16

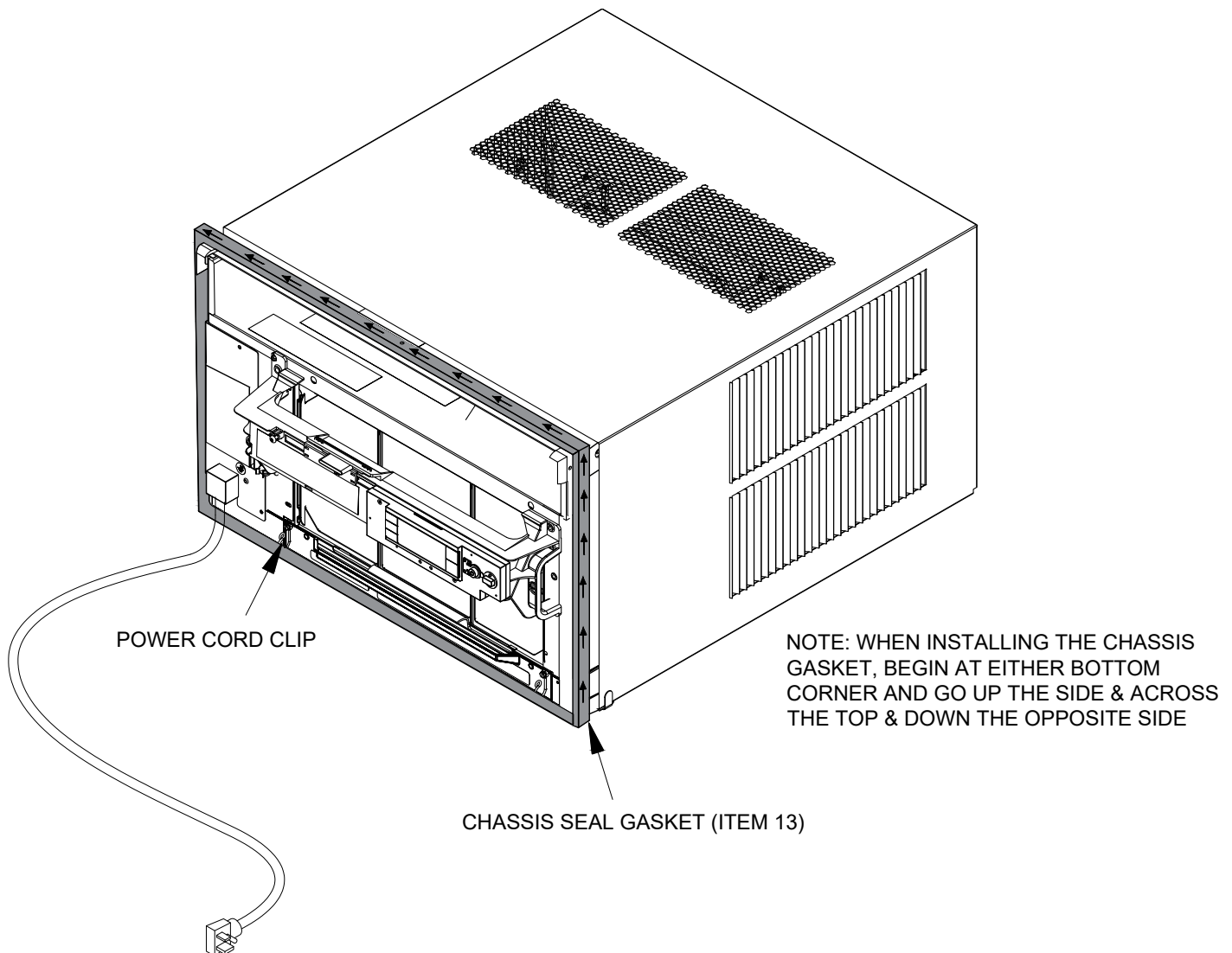



Figure C.4.15

C. INSTALLATION OF THE UNIT



C.5 Thru-the Wall Installation

NOTE: Hardware used during the installation is illustrated in section A. 6

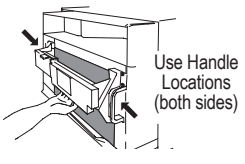
STEP 1. Remove the chassis EntryGard™ retainer by removing the far right screw (see Figure C.5.1). Save this screw to reattach the chassis retainer after installation (Step 12). Also, remove and discard the two retainer screws and washer located at the rear of the unit (see Figure C.5.1).

 CAUTION	
 <p>Use Handle Locations (both sides)</p>	<p>Handle Use</p> <p>Use handle on both sides to pull unit from sleeve.</p> <p>Do not push, pull, or lift from center of support.</p>

STEP 2. Hold the cabinet stationary. Then, use the hand grips on both ends of the control unit support bracket to pull the chassis out of the cabinet (see Figure C.5.2).

 WARNING	
	<p>Fire Hazard</p> <p>A2L refrigerant is classified as mildly flammable. Do not install unit next open flame sources, or surfaces that will exceed 1200 degrees fahrenheit.</p>

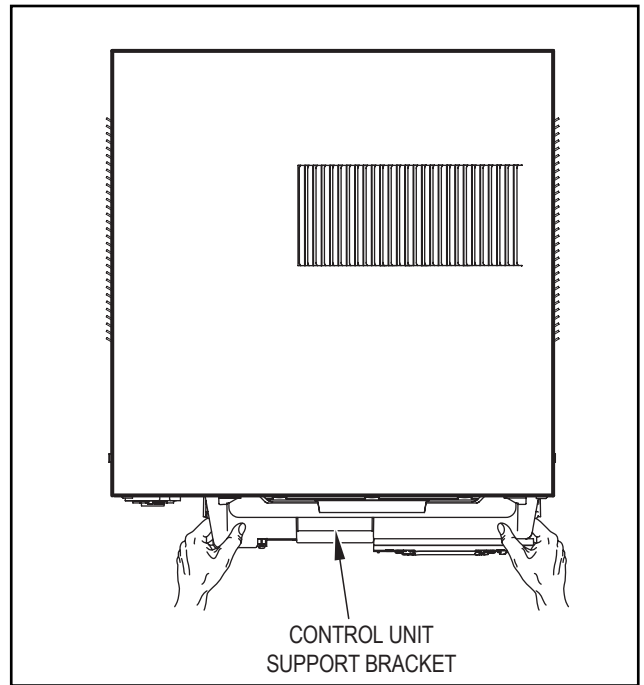

Figure C.5.2

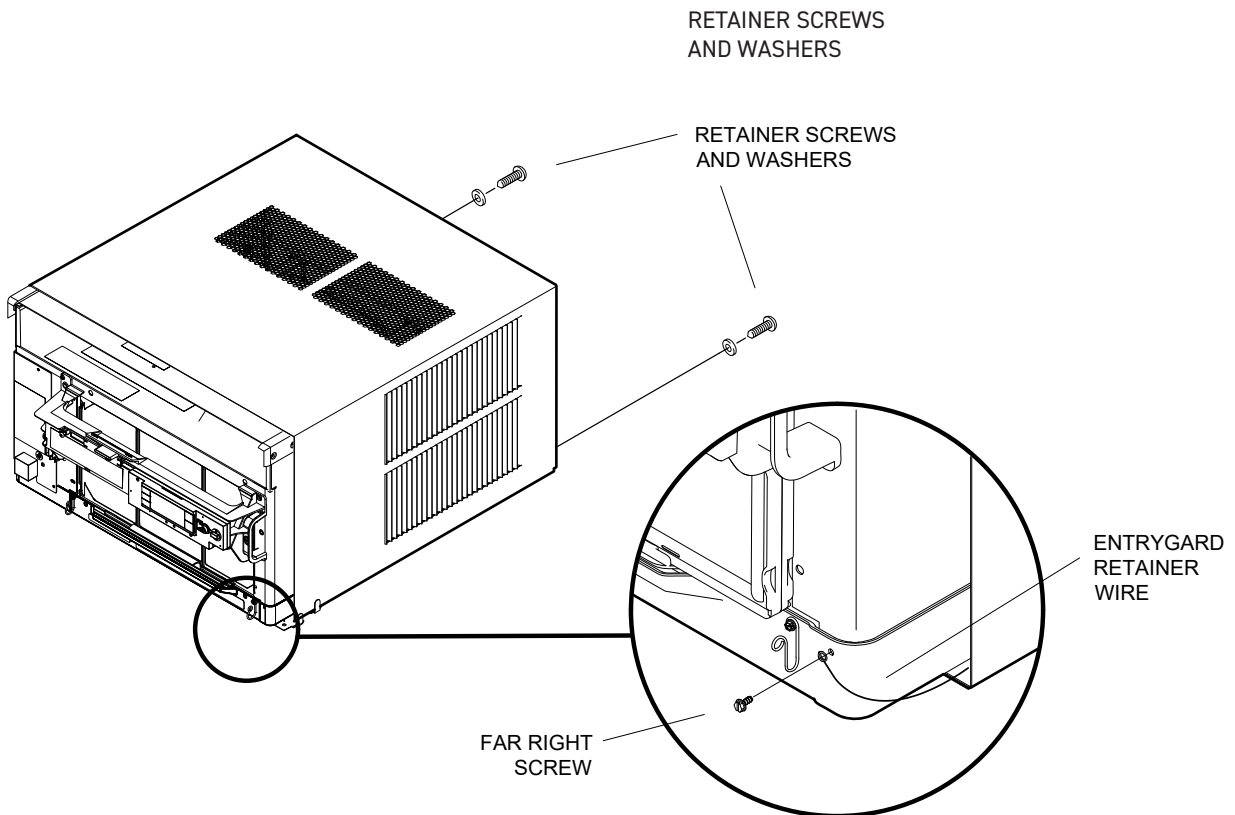

Figure C.5.1

C. INSTALLATION OF THE UNIT

C.5 Thru-the Wall Installation (Cont.)

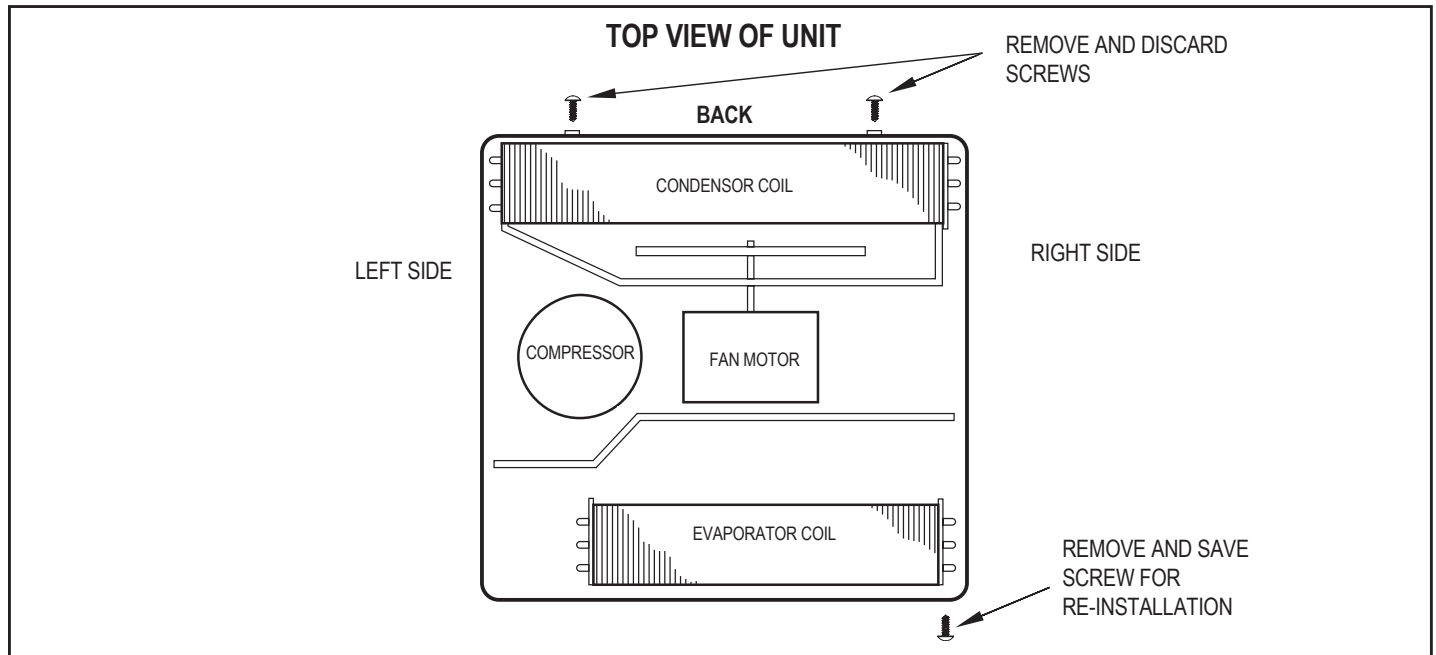

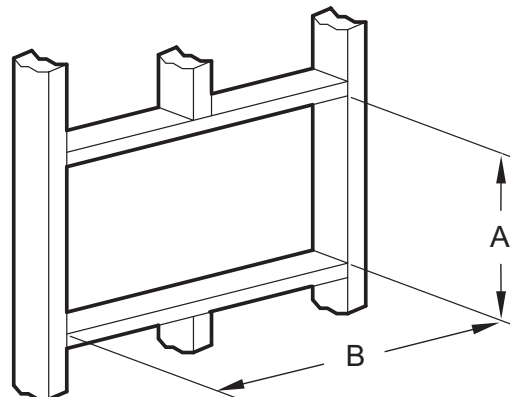

Figure C.5.3

C. INSTALLATION OF THE UNIT

C.5 Thru-the Wall Installation (Cont.)

⚠ WARNING	
	<p>Falling Object Hazard</p> <p>Not following Installation Instructions for mounting your air conditioner can result in property damage, injury, or death.</p>



The following instructions apply to wood, masonry, brick, concrete or cinder block wall construction.

STEP 3. CABINET PREPARATION – Remove the sill plate from the cabinet by removing two (2) nuts and screws (Figure C.5.4). Note that the chassis retainer is secured by a right side nut and screw (Figure C.5.4 Detail 1). Bend the tabs of the sill plate down into its channel at both ends of the plate or cut them off (Figure C.5.4 Detail 2). Rotate the sill plate 180° (end-to-end, Figure C.5.4 Detail 2) and reinstall. Reverse the orientation of the nuts and screws, so that the head of the screws are on the underside of cabinet facing up and the nuts are on top (Figure C.5.4 Detail 3). Ensure that the chassis retainer is reinstalled as shown in the detail.

FINISHED DIMENSION	SMALL CHASSIS	MEDIUM CHASSIS	LARGE CHASSIS
A	16 3/16"	18 3/16"	20 3/8"
B	26 3/16"	26 3/16"	28 1/4"

NOTE: These dimensions are for finished opening size.

NOTICE
<p>The outside cabinet condenser air intake louvers MUST NOT BE BLOCKED by extra thick walls.</p>

STEP 4. WALL PREPARATION – The maximum wall thickness permissible without special construction is determined by the model size to be installed. Observe the maximum wall thickness shown in Figure C.5.6 Walls exceeding the maximum thickness shown in the chart should be altered as shown in Figure C.5.6

STEP 5. CHECKING WIRING AND PLUMBING – Check for wiring and plumbing inside and outside of the wall to be sure none will be damaged when the cabinet framework is being constructed.

STEP 6. OPENING CONSTRUCTION – Depending upon size of unit to be installed, lay out the hole dimensions per Table 3. Cut and frame-in the opening to finished dimensions. If the wall construction is a typical frame, or 2" x 4" studding with brick or stone veneers, locate the opening next to one of the studs. For masonry, concrete, or cinder block walls, locate an opening for your convenience (see Figures C.5.7, C.5.8, C.5.9).

C. INSTALLATION OF THE UNIT

C.5 Thru-the Wall Installation (Cont.)

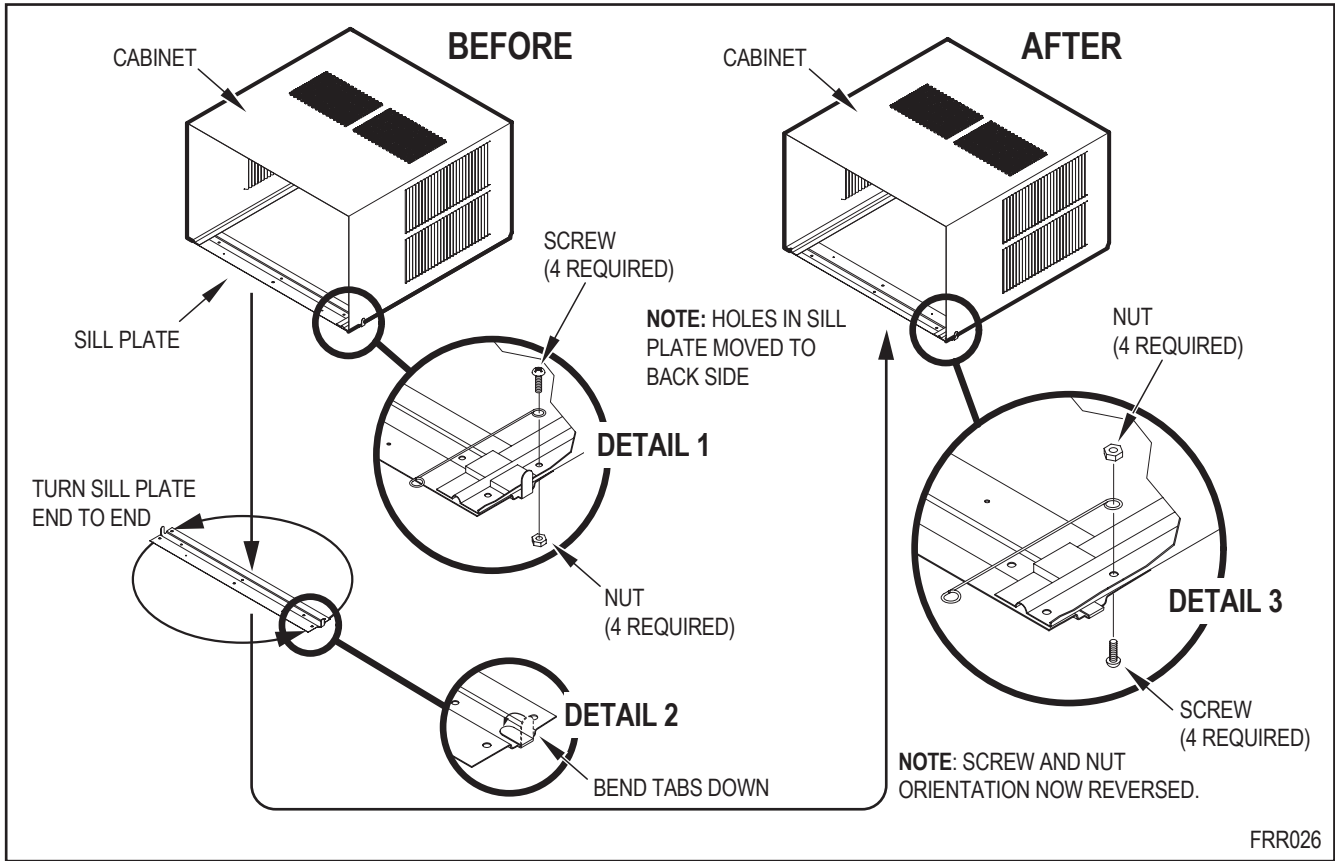

Figure C.5.4

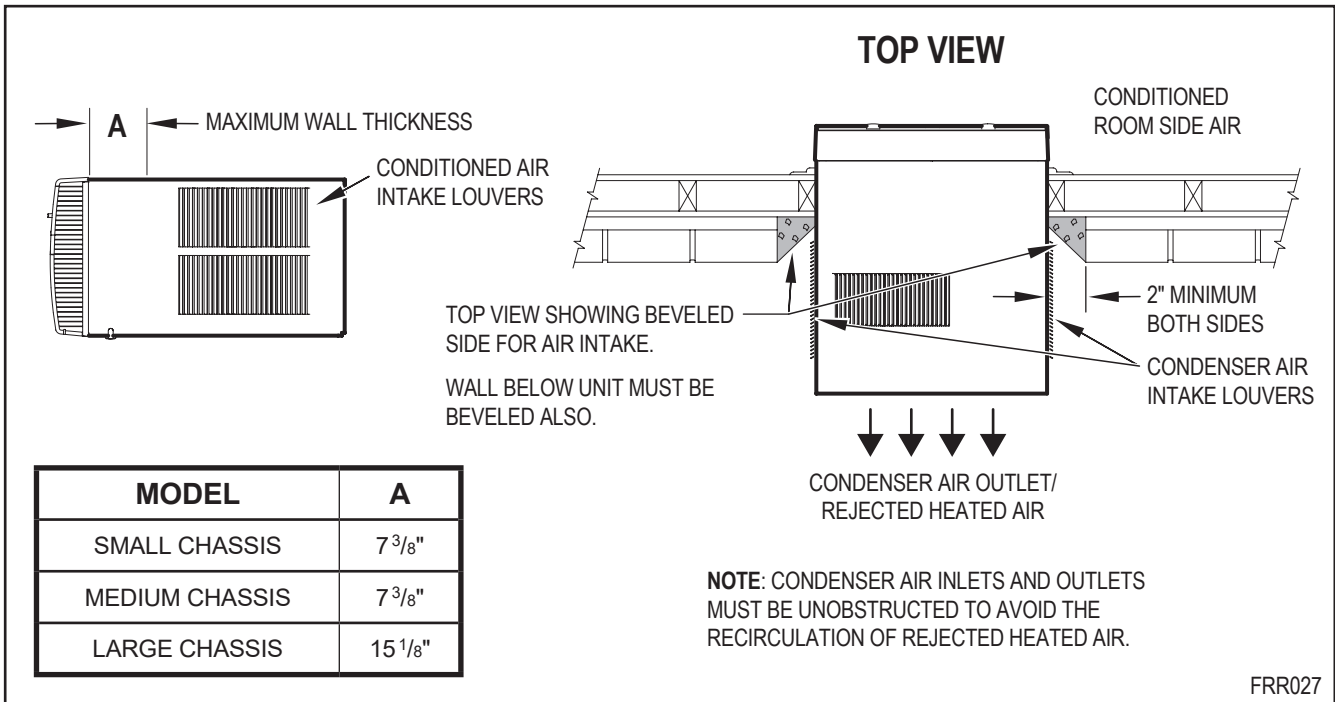

Figure C.5.5

C. INSTALLATION OF THE UNIT

C.5 Thru-the Wall Installation (Cont.)

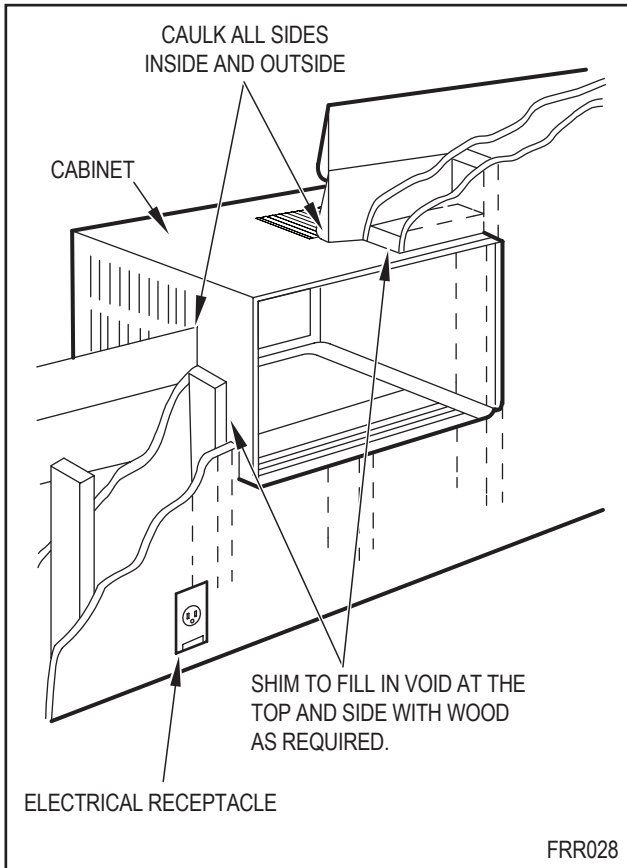

Figure C.5.6

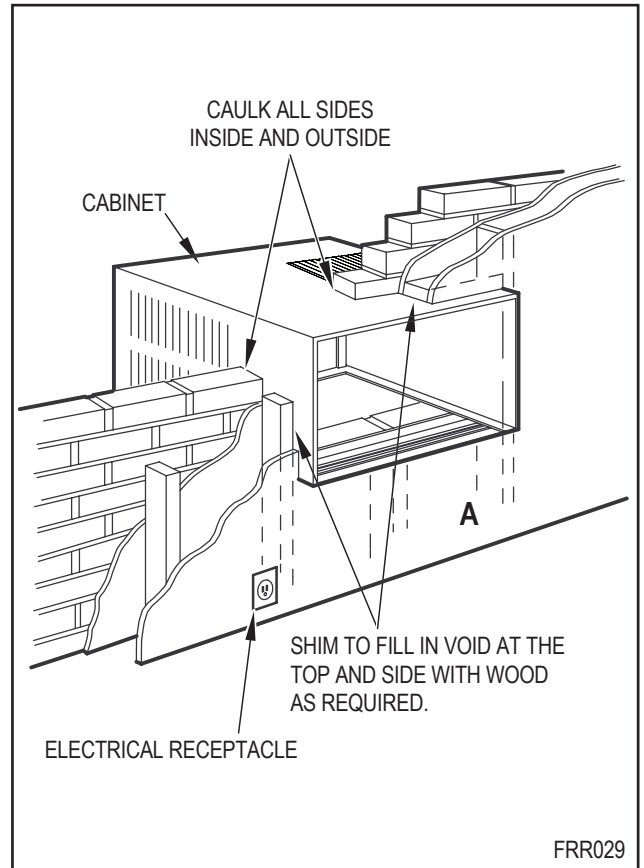

Figure C.5.7

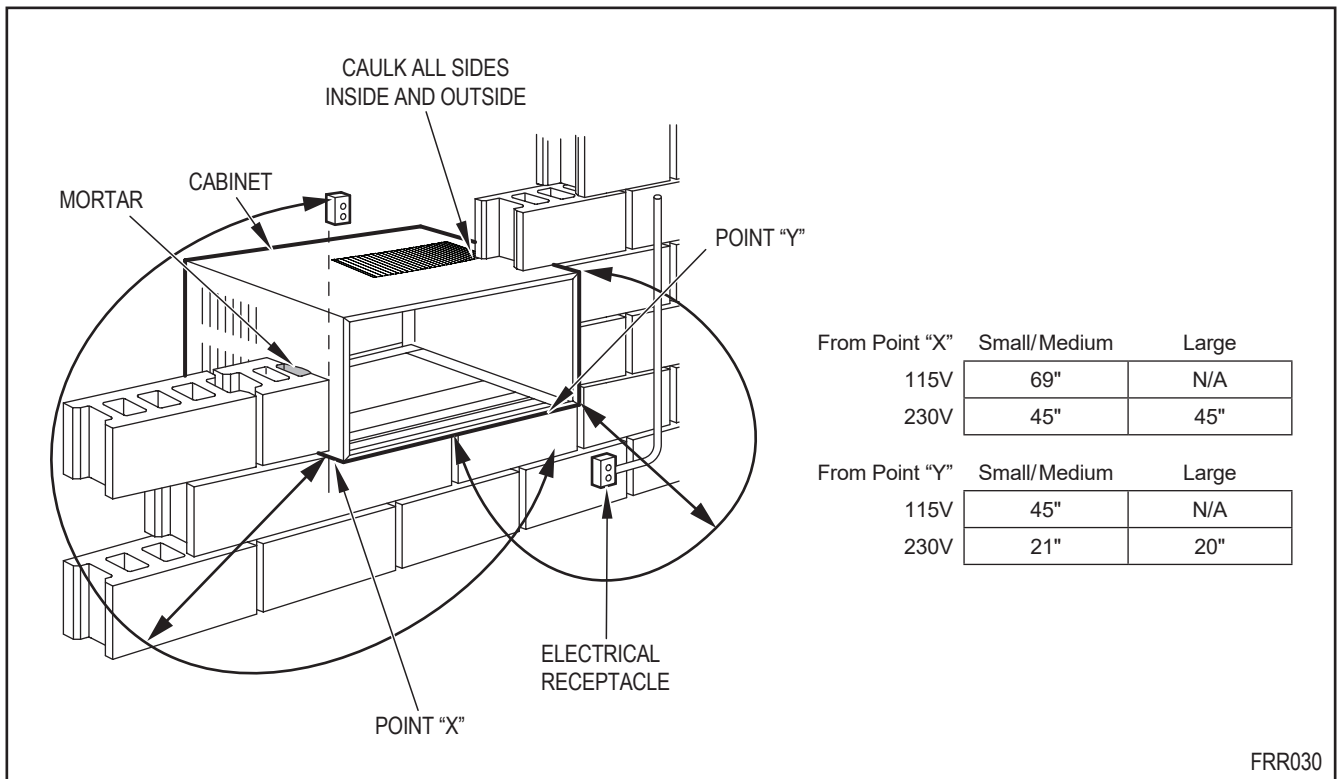

Figure C.5.8

C. INSTALLATION OF THE UNIT

C.5 Thru-the Wall Installation (Cont.)

STEP 8. Slide the cabinet into the hole far enough to allow the guide-channel of the sill plate to contact the inside wall surface (Figure C.5.9).

STEP 9. Drill three (3) $\frac{5}{32}$ " diameter pilot holes (use the sill plate holes as a guide) into the frame and install three (3) #12 x 2" long screws (Item 4) (Figure C.5.9).

NOTE: Alternate fasteners are required when securing the sill plate or support brackets to material other than wood (cinder block, brick, masonry, or concrete). These items can be purchased at your local hardware store.



EXPANSION ANCHOR BOLT

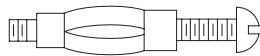

MOLLY OR TOGGLE BOLT

NOTE: DO NOT LEVEL the cabinet from front to back. Make sure there is approximately $\frac{3}{8}$ " to $\frac{1}{2}$ " slope ($\frac{1}{8}$ to $\frac{1}{4}$ bubble on the level) toward the outside of the house.

STEP 10. Drill two (2) $\frac{5}{32}$ " diameter pilot holes in each cabinet side at the locations shown (Figure 83) and install four (4) #12 x 2" screws (Item 4). Provided that Step 5 (hole construction) provides a sturdy mount with solid vertical studs, support brackets may not be required. The installation must support the weight of the unit plus an additional weight of 400 pounds on the rear of the cabinet. If support brackets (Item 1) are available, they can be installed as shown in Figure C.5.9

STEP 11. Carefully team lift the chassis and set it into the cabinet. Slide the chassis stopping approximately 3" from full insertion. Insert the chassis seal gasket (Item 13) one inch deep between the chassis and the cabinet (see Figure C.5.10). A paint stir stick or ruler might be helpful here. Begin inserting the gasket at either bottom corner and go up the side, across the top, and down the opposite side. Then push the chassis all the way into the cabinet.

NOTE: If the chassis seal gasket is not installed or installed improperly, the operation of the unit will be negatively affected. Operational noise and outside noise will also amplified.

STEP 12. Reattach the EntryGard™ chassis and EntryGard™ retainer wire with the same screw retained in Step 1 (see Figure C.5.1)..

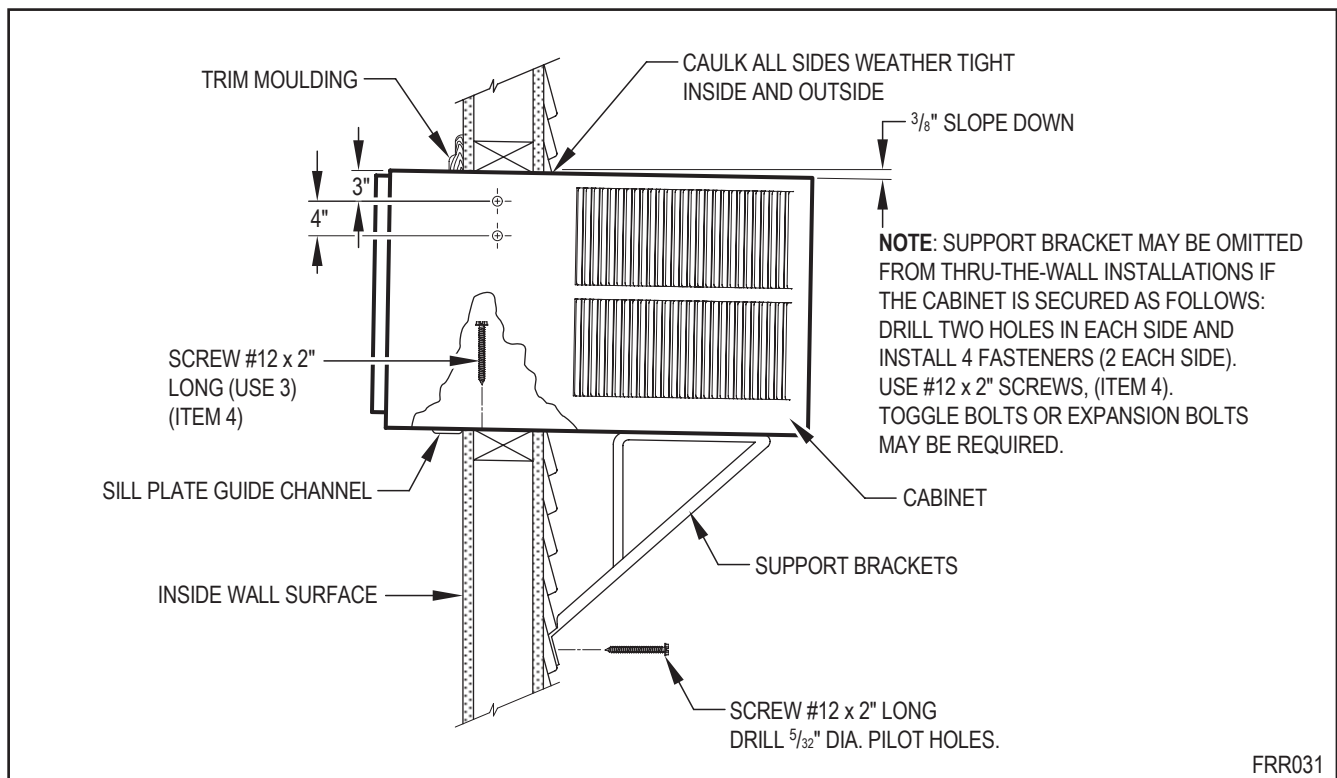

Figure C.5.9

C. INSTALLATION OF THE UNIT

C.5 Thru-the Wall Installation (Cont.)

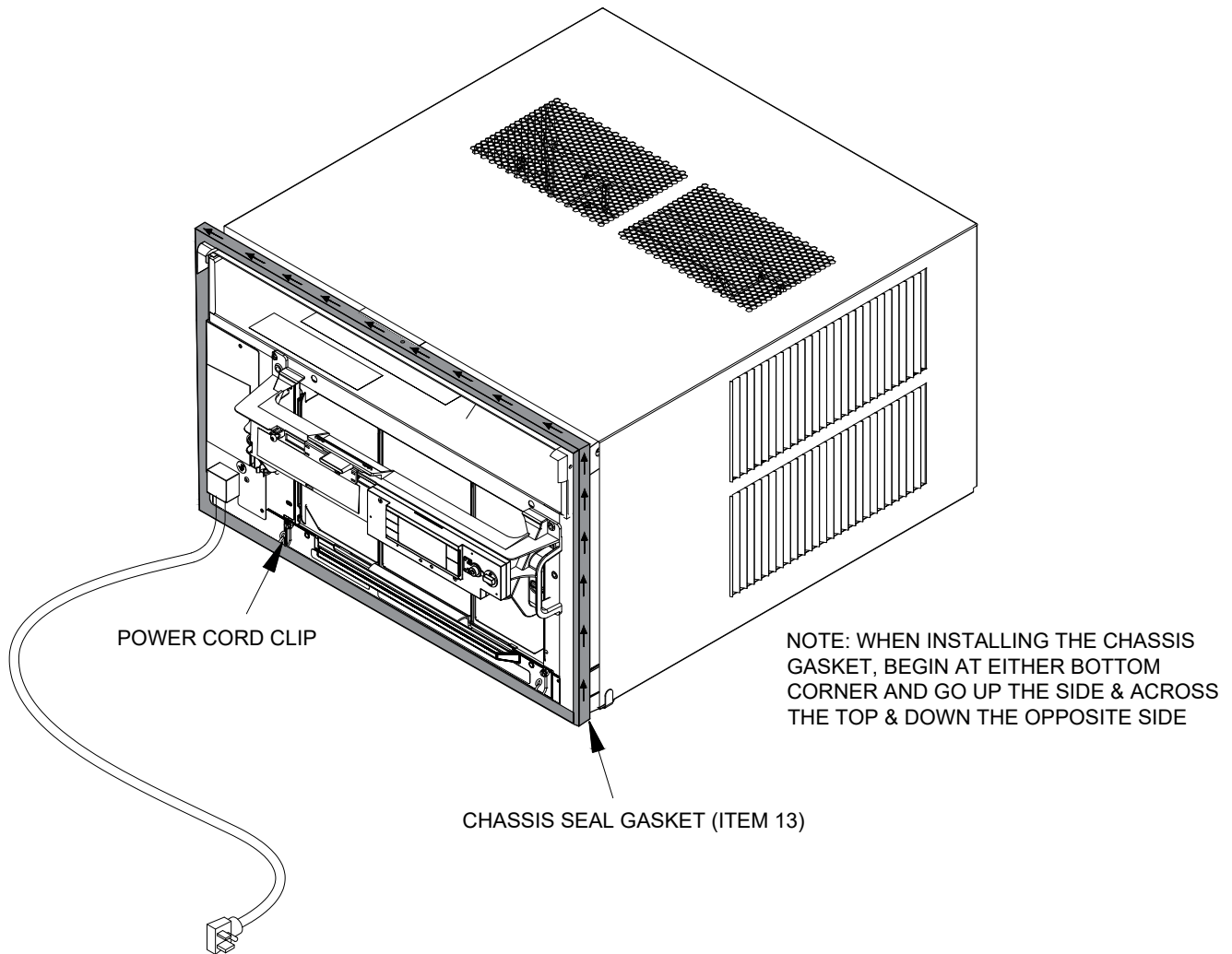

Figure C.5.10

OPTIONAL: The factory assembles the supply cord so that it exits the left side of the unit at the bottom. At the consumer's discretion, pull the supply cord taut through the loops (refer to Cord Routing Change, Section C.6) and route the cord down.

STEP 13. To attach and prevent damage to the front grille, align the cord notch over the cord and center the fresh air lever, then align and tighten the four (4) captive screws as indicated by the arrows in Figure C.5.11 (Preferred tool is a 1/4" nut driver) Before closing the front panel, be sure the filter is in place. Make sure curtains do not block the side air intakes.

STEP 14. Refer to the Control Panel Operation section for instructions.

You are now to control the comfort level of the room.

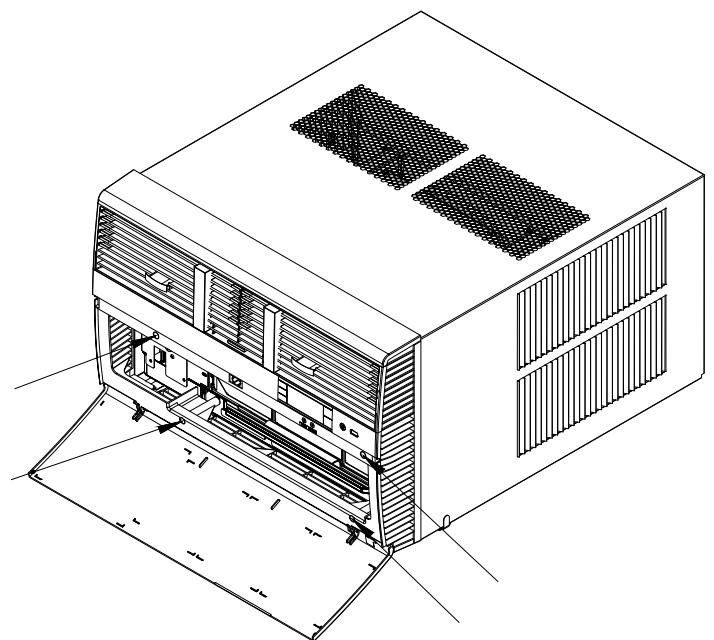



Figure C.5.11

C. INSTALLATION OF THE UNIT

C.6 Cord Routing Change

Unplug unit.

⚠ WARNING	
	<p>Electrical Shock Hazard</p> <p>Make sure your electrical receptacle has the same configuration as your air conditioner's plug. If different, consult a Licensed Electrician.</p> <p>Do not use plug adapters. Do not use an extension cord. Do not remove ground prong.</p> <p>Always plug into a grounded 3 prong outlet. Failure to follow these instructions can result in death, fire, or electrical shock.</p>

STEP 1 Remove the 3 screws as shown from the access panel. Save to reinstall later.

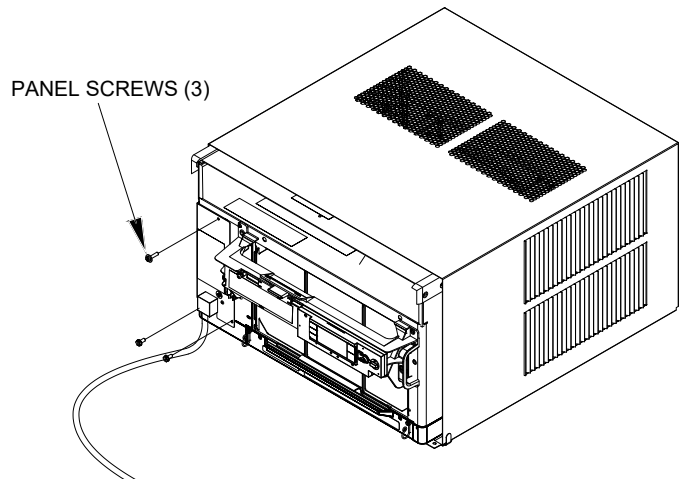

Figure C.6.2

For convenience and optimum appearance, the direction that the power cord exits the unit may be changed from left to right by following the procedure below. Select the exit location on the left or right based on proximity to the power outlet.

The 30 Amp power Cord installation is shown in Figure C.6.1. If your unit plug is in this configuration, you do not need to rotate plug in order to change the routing. You can skip to step 5.

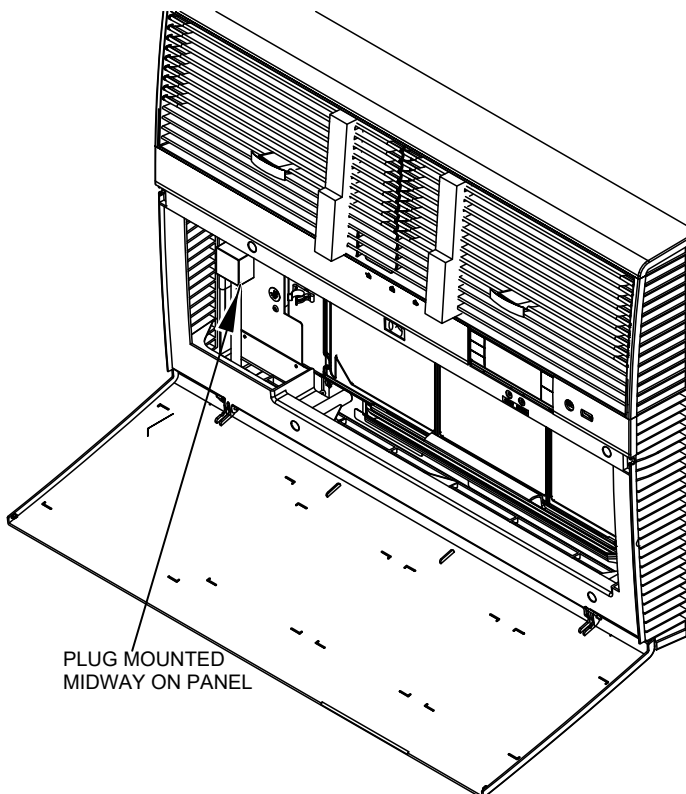

Figure C.6.1

STEP 2. Pull electrical cord strain relief downward until free and rotate 90 degrees to the right.

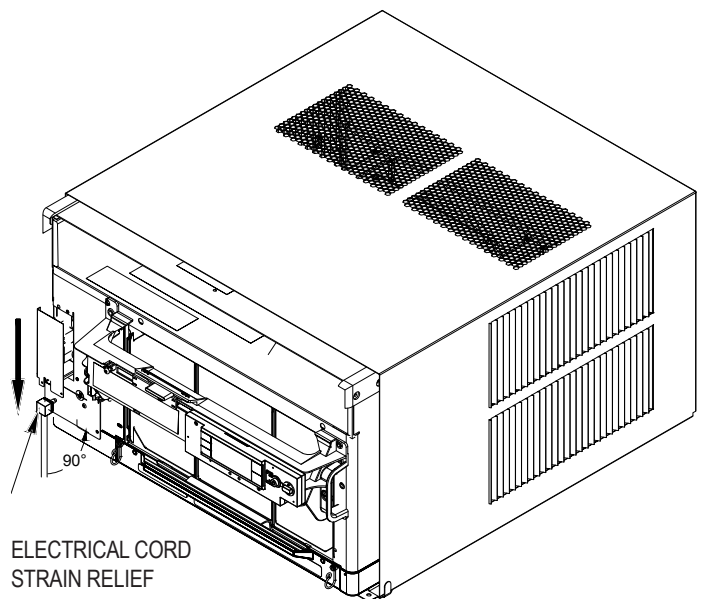
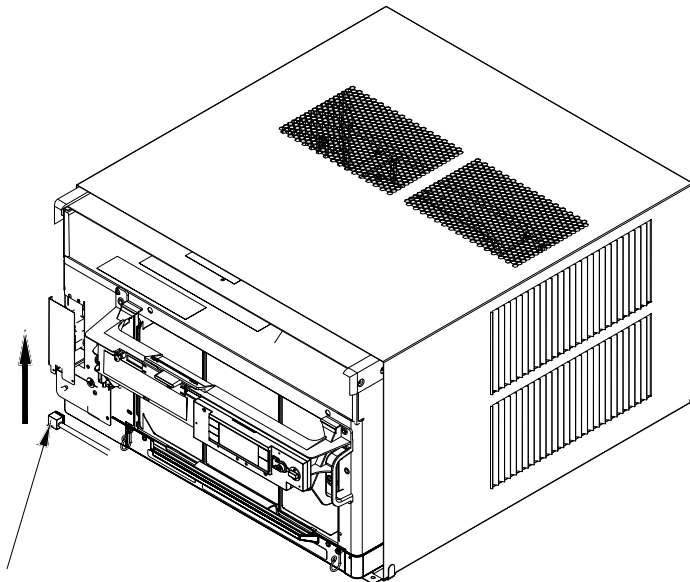

Figure C.6.3

C. INSTALLATION OF THE UNIT

C.6 Cord Routing Change

STEP 3. Push electrical cord strain relief back upward into the electrical control panel.



ENSURE THE ELECTRICAL CORD STRAIN RELIEF IS FLUSH WITH THE TOP OF ELECTRICAL CONTROL PANEL.

Figure C.6.4

STEP 4. Reinstall the 3 screws removed earlier to secure electrical control panel.

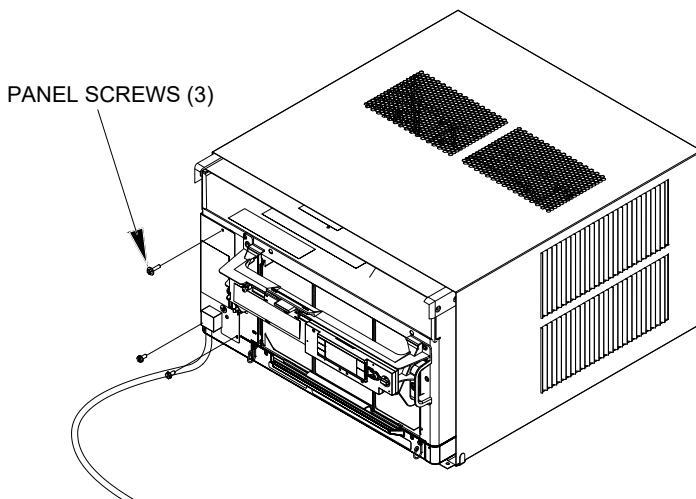

Figure C.6.5

STEP 5. If running power cord to the right of the unit, install the cord into the cord retainer clips along the bottom front of the unit.

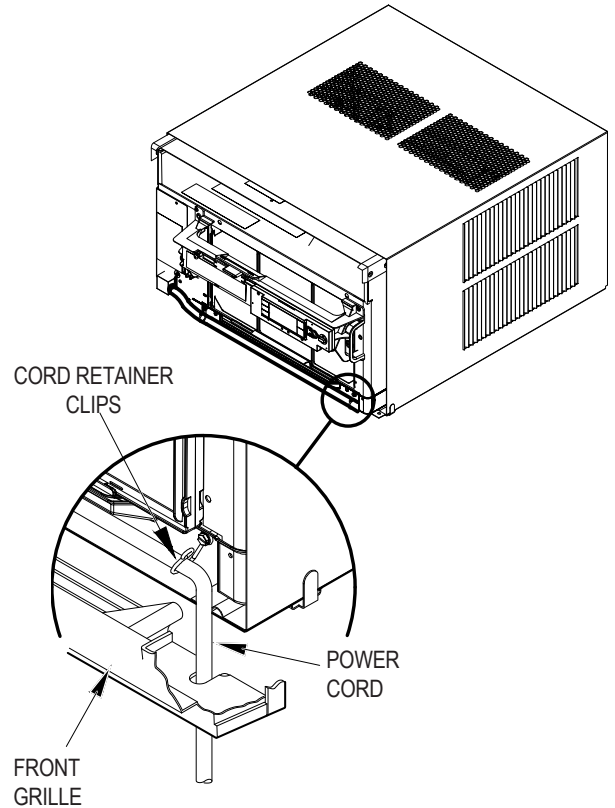

Figure C.6.6

C. INSTALLATION OF THE UNIT

C.7 Install Filter

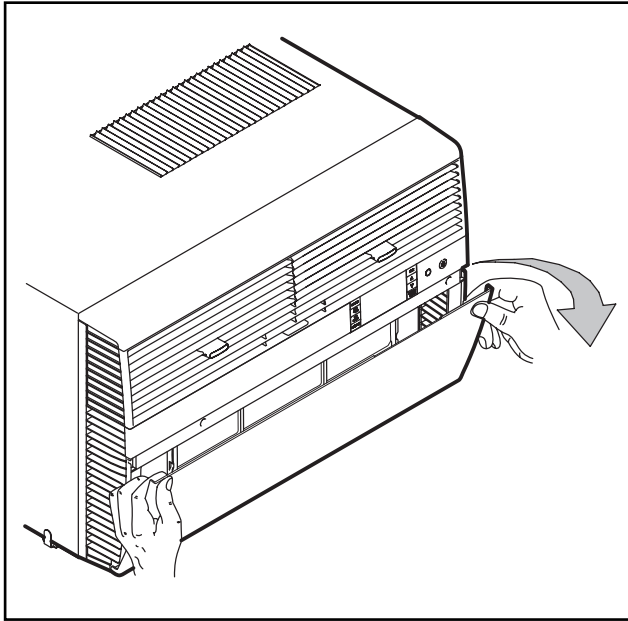

Figure C.7.1

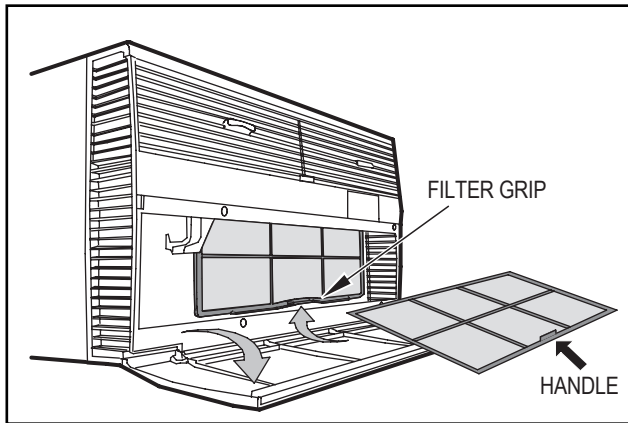

Figure C.7.2

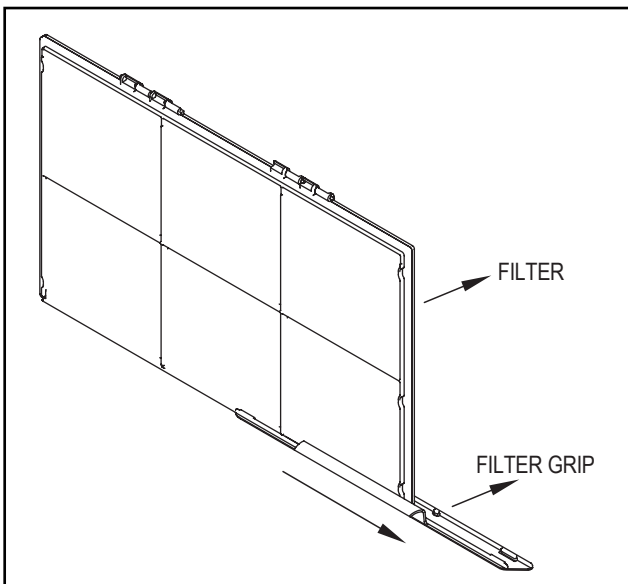

Figure C.7.3

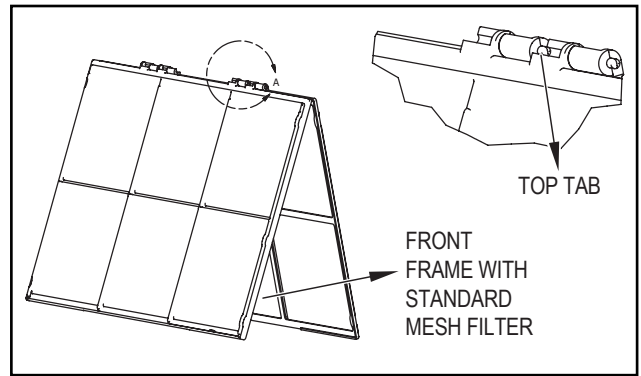

Figure C.7.4

STEP 1. Swing the door open and remove the filter by grasping the filter holder and pushing the filter holder upward and outward. (See Figure C.7.2)

STEP 2. Slide the filter grip out from the filter as shown in Figure C.7.3.

NOTE: Make sure the front frame with the mesh filter is facing you.

STEP 3. If you already have a carbon filter installed remove the dirty filter by laying the filter down and swinging open the front frame as shown in Figure C.7.4. Clean the front frame by washing the dirt from the filter. Use a mild soap solution if necessary. Allow filter to dry.

STEP 4. (Optional) Place the new carbon filter on the top of the back filter frame. The carbon filter has been cut to the correct dimension and should fit within the frame as shown in Figure C.7.5.

NOTE: The carbon filter is not a reusable filter, and needs to be replaced every three months for optimum efficiency.

STEP 5. Slide the filter handle back on to hold the frames together and slide the assembly into the unit as per the instructions on the door.

NOTE: The filter handle slides into the frame in only one direction. If the tab in the frame stops the handle from sliding in, slide the handle from the other direction. DO NOT FORCE THE HANDLE INTO THE FRAME.

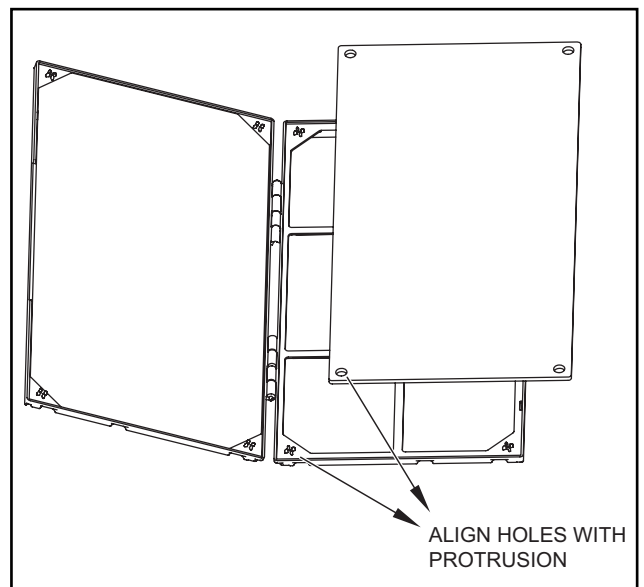



Figure C.7.5

E. ELECTRICAL

E.1 Electrical Safety Information

⚠ WARNING



Electrical Shock Hazard

Make sure your electrical receptacle has the same configuration as your air conditioner's plug. If different, consult a Licensed Electrician.

Do not use plug adapters.
Do not use an extension cord.
Do not remove ground prong.

Always plug into a grounded 3 prong outlet.
Failure to follow these instructions can result in death, fire, or electrical shock.

Make sure the wiring is adequate for your unit.

If you have fuses, they should be of the time delay type. Before you install or relocate this unit, be sure that the amperage rating of the circuit breaker or time delay fuse does not exceed the amp rating listed in Table 1.





DO NOT use an extension cord.

The cord provided will carry the proper amount of electrical power to the unit; an extension cord may not.

Make sure that the receptacle is compatible with the air conditioner cord plug provided.

Proper grounding must be maintained at all times. Two prong receptacles must be replaced with a grounded receptacle by a certified electrician.

The grounded receptacle should meet all national and local codes and ordinances. You must use the three prong plug furnished with the air conditioner. Under no circumstances should you remove the ground prong from the plug.

Table E.1				
MODEL	CIRCUIT RATING OR TIME DELAY FUSE		REQUIRED WALL RECEPTACLE	
	AMP	VOLT	NEMA NO.	
KCVS08B10A, KCVS12B10A, KCVM14B10A, KHVS10B11A	15	125	5-15R	
KCVS12B30A, KCVS16B30A, KCVM18B30A	15	250	6-15R	
KHVS12B33A, KCVM24B30A, KCVL28B30A, KEVS16B33A	20	250	6-20R	
KHVM24B30A, KHVL28B35A, KCVL36B30A, KEVL36B35A	30	250	6-30R	

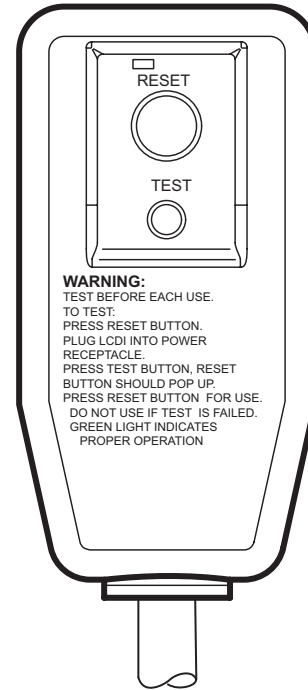

E.2 Testing the Power Cord

All Friedrich room air conditioners are shipped from the factory with a Leakage Current Detection Interrupter (LCDI) equipped power cord. The LCDI device on the end of the cord meets the UL and NEC requirements for cord connected air conditioners.

To test your power supply cord:

1. Plug power supply cord into a grounded 3 prong outlet.
2. Press RESET (see Figure 1).
3. Press TEST, listen for click; the RESET button trips and pops out.
4. Press and release RESET (Listen for click; RESET button latches and remains in). Check that the green LED light is on. The power cord is ready for use.

Once plugged in, the unit will operate normally without the need to reset the LCDI device. If the LCDI device fails to trip when tested or if the power supply cord is damaged, it must be replaced with a new power supply cord from the manufacturer.

NOTICE

Do not use the LCDI device as an ON/OFF switch.

Failure to adhere to this precaution may cause premature equipment malfunction.

J. STARTUP AND OPERATION

J.1 Final Inspection

- Inspect and ensure that all components and accessories have been installed properly and that they have not been damaged during the installation progress.
- Check the condensate water drain(s) to ensure that they are adequate for the removal of condensate water, and that they meet the approval of the end user.
- Ensure that all installation instructions concerning clearances around the unit have been adhered to. Check to ensure that the unit air filter, indoor coil, and outdoor coil are free from any obstructions.
- Inspect the unit for any damage to the coils and tubing that could cause a leak.
- Ensure that the circuit breaker(s) or fuse(s) and supply circuit wire size have been sized correctly. If the unit was supplied with a power supply cord, insure that it is stored properly.
- Ensure that the entire installation is in compliance with all applicable national and local codes and ordinances having jurisdiction.
- Secure components and accessories, such as a decorative front cover.
- Start the unit and check for proper operation of all components in each mode of operation.
- Instruct the owner or operator of the units operation, and the manufacturer's Routine Maintenance.

NOTE: A log for recording the dates of maintenance and/or service is recommended.

J.2 Air Flow Selection and Adjustment

Airflow direction adjustment

The airflow path may be adjusted to distribute air independently from the left or right side of the discharge opening. Each of the banks of louvers can be directed left, right, up, or down in order to achieve the most optimum airflow positioning.

To adjust airflow direction, grab the lever in the center of the louver bank and move it in the direction that you would like the air to be directed. Please note that it is normal that airflow may be stronger out of one side of the louvers than the other.

Fresh air and exhaust control

Your air conditioner has the ability to bring fresh air into the room or exhaust stale air out of the room. The control slide is found on the upper part of the unit (see Figure 53).

TO BRING IN FRESH AIR – Move the lever to the **Fresh Air**  position which allows outside air to enter the room. This is useful in fall and spring as a means of bringing in fresh outside air when using FAN ONLY. It can also be used in the summer with the compressor in the Cooling Mode if you wish.

TO EXHAUST INDOOR AIR – Move the lever to the **Exhaust**  position. This will allow stale air to be expelled to the outside of the dwelling. This is especially handy in the spring or fall when indoor air tends to get stale, or after a social gathering involving smokers, or to remove cooking odors.

BEST PERFORMANCE – Move the lever to the **Re-Circulate Position**.  This is the most efficient mode for cooling and heating.

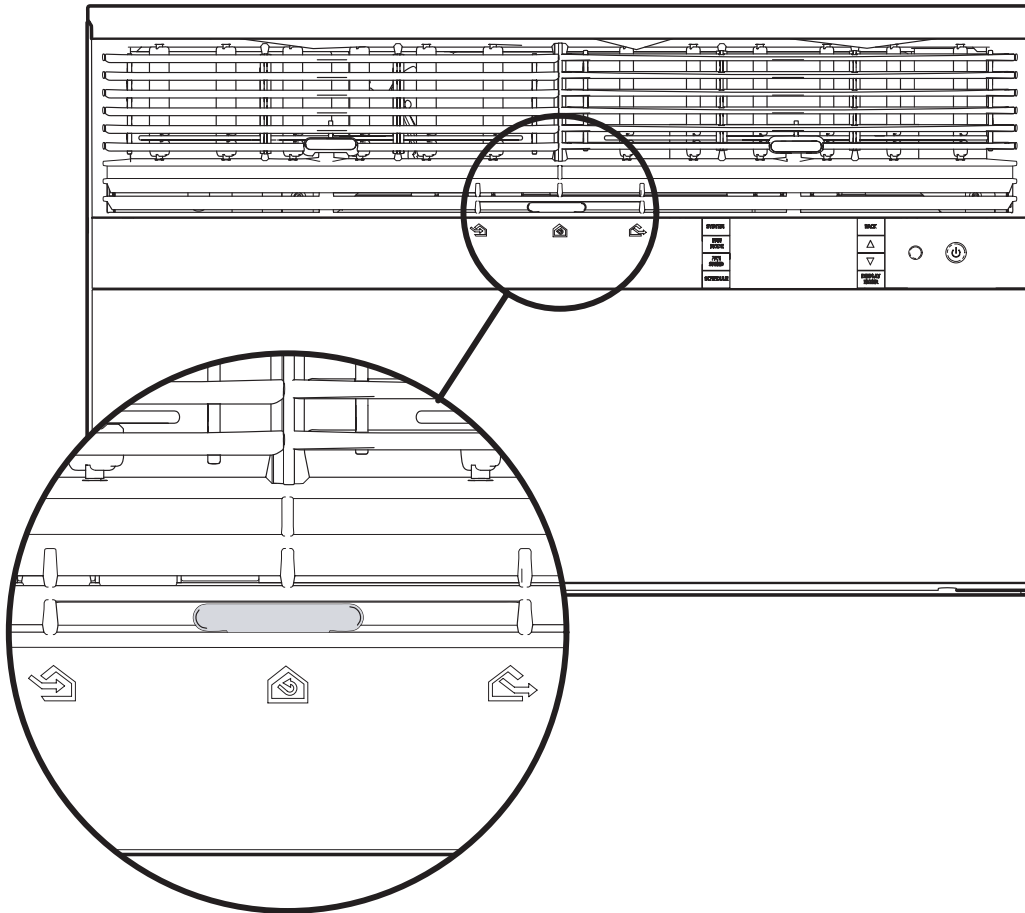

Figure J.2.1

J. STARTUP AND OPERATION

J.3 Control Panel Operation

SYSTEM - The **MODE** button allows you to sequentially select up to four modes of operation:

AUTO	Available on select models
COOL	
HEAT	Available on select models
FAN ONLY	

AUTO FAN (No Cooling Demand)

When in **AUTO** mode, the fan only operates when the system has a demand to cool or heat the room.

In the **ON** fan mode, the fan operates all the time. The system periodically cools or heats the fan's airflow but the flow of air does not stop.

UP and DOWN Arrows - Pressing either an **UP** or **DOWN** button changes the system's setpoint (desired room temperature). These buttons are also used to make system parameter changes later in this manual.

One press equals 1 degree of change in Fahrenheit mode. One press equals 0.5 degree change in Celsius mode.

TIMER

The timer can be engaged or disengaged from the control panel. This is done by pressing or holding the **UP** and **DOWN** arrows simultaneously for three seconds.

OTHER FUNCTIONS

°F–°C Select

To switch from degrees Fahrenheit (F) to Celsius (C), press the **MENU** button and enter the **F-C** sub-menu.

FAN SPEED - Depending on your model, the **FAN SPEED** button allows you to toggle between three or four modes of operation: LOW, MEDIUM, HIGH and MAX.

Alerts

When the filter needs to be cleaned or replaced, the **CHECK FILTER** icon displays.

The alert can be dismissed by pressing the **FAN MODE** and **SPEED** for 3 seconds.

Lock Control Panel

To lock/unlock the front panel controls, navigate to the "**LOCK**" sub-menu found after clicking the **MENU** button. The lock requires a four digit pass code to lock/unlock the unit. This pass code will be required to enter the menu to unlock the unit. The **LOCK** icon illuminates to indicate the locked status.

The **LOCK** icon disappears to indicate unlocked status.

External Control Status

The **Wi-Fi** icon illuminates to indicate that the system is receiving a Wi-Fi connection. The **Wi-Fi** icon also provides information about the signal strength.

ADVANCED FUNCTIONS

The functions mentioned in the following section may or may not be available depending on the air conditioner model.

Modify the TIMER Function

Navigate to the TIME menu to set the timer.

J. STARTUP AND OPERATION

J.3 Control Panel Operation

All of the control panel function buttons and mode icons can be viewed in Figure 8.

Power On – Press the button to turn on the air conditioner. The power button illuminates to indicate that the power is on. The backlight on the power switch will automatically turn off after 20 seconds of inactivity.

Display – The display is a high efficiency LCD with a built-in backlight. After 20 seconds of inactivity, the display switches off. Touching any button automatically changes the display to full brightness.

There are three control push buttons on each side of the display.

SYSTEM Cycles between AUTO, HEAT, COOL, or FAN ONLY (if equipped)	FAN MODE Sets fan to either: - Cycle automatically - Run continuously	FAN SPEED Sets fan speed: LOW, MED, HIGH or AUTO (if equipped)	TEMPERATURE Increment UP TEMPERATURE Increment DOWN	TIMER Turns ON or OFF	IR WINDOW Do not block	ON / OFF Turns unit on/off
---	---	--	--	---------------------------------	----------------------------------	--------------------------------------

Figure J.3.1

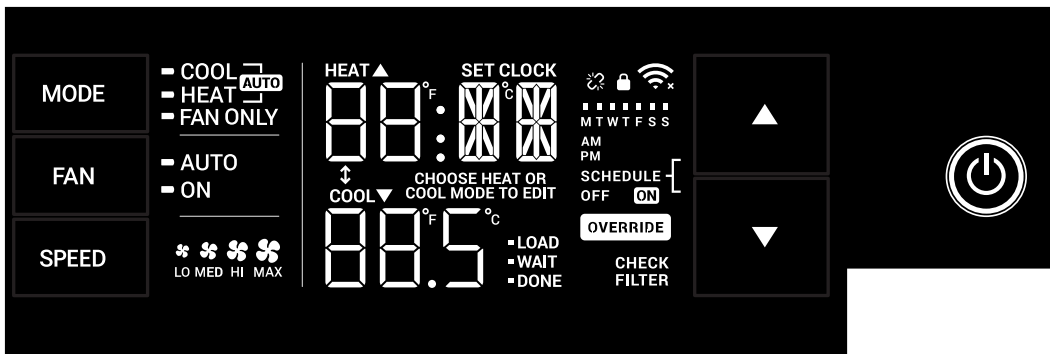
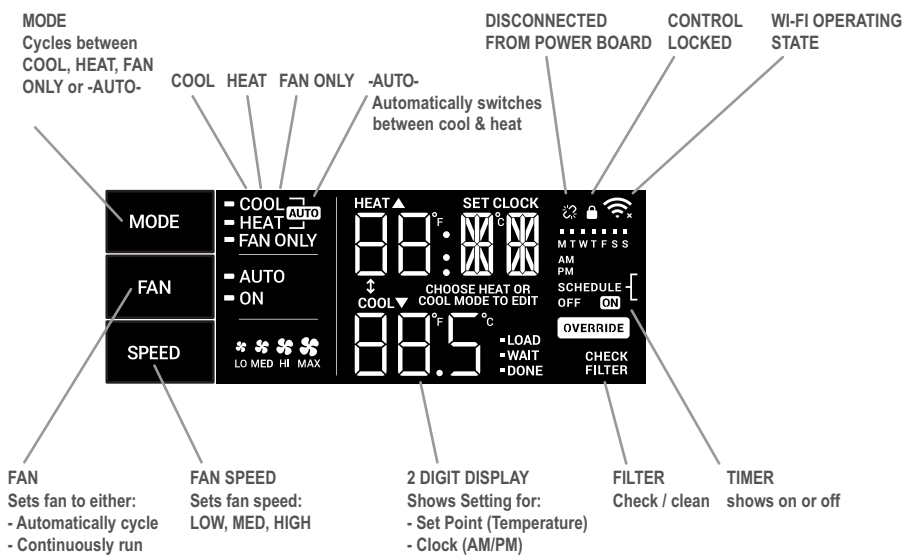

Figure J.3.2



J. STARTUP AND OPERATION

J.4 Remote Control Operation

Remote Control - Refer to Figure J.4.1 during operation description.

Getting Started - Install two (2) AAA batteries in the battery compartment located on the back of the unit.

Operation - The remote control should be within 25 feet of the air conditioner for operation. Press the power button to turn the remote on. The remote will automatically power off after 15 seconds if the buttons are not being pressed. The remote must be on to control the unit.

POWER Button - Turns remote and unit on and off.

SYSTEM Button - Allows the user to sequentially select the following: **AUTO**, **COOL**, **HEAT**, and **FAN ONLY** operations. When the button is pressed, the display indicates which mode has been selected via a display message. Note that when the heating function is not available, the system will automatically skip the HEAT mode.

FAN MODE Button - Selects between automatic (**AUTO FAN**) or **CONTINUOUS** operation. In the **AUTO FAN** mode, the fan only turns on and off when the compressor operates or the heat function is enabled.

NOTE: **AUTO FAN** is not available in the **FAN ONLY** Mode, the display indicates **CONTINUOUS**. In the **CONTINUOUS** mode, fan speed is determined by your selection on the **FAN SPEED** button.

FAN SPEED Button - Used to sequentially select new fan speed, plus **AUTO** operation. When the **FAN SPEED** button is pressed, the fan speed icon (triangle)

changes to indicate the new speed level. Fan speed automatically varies depending on the set temperature on the control panel and the actual room temperature. For example, if there is a big difference between your set temperature and the actual room temperature, the system fan speed increases to **HIGH**. It remains at this speed until the room temperature matches the set temperature.

UP and DOWN Arrows - Pressing either the **UP** or **DOWN** button changes the desired room temperature. The factory preset lower and upper limits are 60 °F (16 °C) and 99 °F (37 °C). These buttons are also used to navigate between function options when using the User Menu or Maintenance Mode.

Remote Effectiveness

Handheld Remote - Has an operating range of up to 25 ft. The infrared remote control signal must have a clear path to transmit the command to the air conditioning unit. The remote signal has some ability to “bounce” off of walls and furniture similar to a television remote control. The diagram below shows the typical operating range of the control in a standard room with 8 ft high ceilings.

J.5 Start-up

This is a warm weather appliance

Your air conditioner is designed to cool in warm weather when the outside temperature is above 60 °F (15.6 °C) and below 115 °F (46.1 °C), so it won't cool a room if it is already cool outside. If you want to cool a room in the spring or fall, select the **FAN ONLY** mode and set the Fresh Air/Exhaust air control to Fresh Air. This will bring in a supply of cooler outside air.

Condensation is normal

Air conditioners actually pump the heat and humidity from your room to the outside. Humidity becomes water, and your air conditioner will use most of the water to keep the outside coil cool. If there is excessive humidity, there may be excess water that will drip outside. This is normal operation.

Frosting

This usually occurs because of insufficient airflow across the coils, a dirty filter, cool damp weather, or all these. Set the **SYSTEM** mode to **FAN ONLY** and the frost will disappear. Setting the thermostat a little warmer will probably prevent the frosting from recurring.

Noises

All air conditioners make some noise. Friedrich units are designed to operate as quietly as possible. An air conditioner mounted in a wall is quieter than one mounted in a window. It is important to ensure that the chassis seal gasket (Item 13) is properly installed (refer to the Installation Instructions).

NOTICE

This unit is certified to operate in cooling mode under these maximum conditions. Any operation beyond these conditions may result in intermittent operation.

Indoor temperature: 90 °F (45% relative humidity)

Outdoor temperature: 110 °F (25% relative humidity)

If unit is heat pump equipped, it is certified to operate in heating mode under these maximum conditions. Any operation beyond these conditions may result in intermittent operation.

Indoor temperature: 80 °F (humidity does not affect operation)

Outdoor temperature: 70 °F (60% relative humidity)

L. WiFi

Use a QR Reader on your phone to Scan this QR Code. It will take you to the Wifi Instructions page of our website..



M. TROUBLESHOOTING

M.1. Troubleshooting Tips

COMPLAINT	CAUSE	SOLUTION
Unit does not operate.	<ul style="list-style-type: none"> The unit is turned to the off position, or the thermostat is satisfied. 	<ul style="list-style-type: none"> Turn the unit to the on position and raise or lower temperature setting (as appropriate) to call for operation.
	<ul style="list-style-type: none"> The LCDI power cord is unplugged. 	<ul style="list-style-type: none"> Plug into a properly grounded 3 prong receptacle. See “Electrical Rating Tables” on Page 6 for the proper receptacle type for your unit.
	<ul style="list-style-type: none"> The LCDI power cord has tripped (Reset button has popped out). 	<ul style="list-style-type: none"> Press and release RESET (Listen for click. Reset button latches and remains in.) to resume operation.
	<ul style="list-style-type: none"> The circuit breaker has tripped or the supply circuit fuse has blown. 	<ul style="list-style-type: none"> Reset the circuit breaker, or replace the fuse as applicable. If the problem continues, contact a licensed electrician.
	<ul style="list-style-type: none"> There has been a local power failure. 	<ul style="list-style-type: none"> The unit will resume normal operation once power has been restored.
Unit Trips Circuit Breaker or Blows Fuses.	<ul style="list-style-type: none"> Other appliances are being used on the same circuit. 	<ul style="list-style-type: none"> The unit requires a dedicated outlet circuit, not shared with other appliances.
	<ul style="list-style-type: none"> An extension cord is being used. 	<ul style="list-style-type: none"> Do NOT use an extension cord with this or any other air conditioner.
	<ul style="list-style-type: none"> The circuit breaker or time-delay fuse is not of the proper rating. 	<ul style="list-style-type: none"> Replace with a circuit breaker or time-delay fuse of the proper rating. See Table E.1 for the proper circuit breaker/fuse rating for your unit. If the problem continues, contact a licensed electrician.
LCDI Power Cord Trips (Reset Button Pops Out).	<ul style="list-style-type: none"> The LCDI power cord can trip (Reset button pops out) due to disturbances on your power supply line. 	<ul style="list-style-type: none"> Press and release RESET (Listen for click. Reset button latches and remains in.) to resume normal operation.
	<ul style="list-style-type: none"> Electrical overload, overheating, or cord pinching can trip (Reset button pops out) the LCDI power cord. 	<ul style="list-style-type: none"> Once the problem has been determined and corrected, press and release RESET (Listen for click. Reset button latches and remains in.) to resume normal operation.
	<p>NOTE: A damaged power supply cord must be replaced with a new power supply cord obtained from the product manufacturer and must not be repaired. The power cord must be replaced by trained service personnel.</p>	
Unit Does Not Cool/Heat Room Sufficiently, or Cycles On And Off Too Frequently.	<ul style="list-style-type: none"> The return/discharge air grille is blocked. 	<ul style="list-style-type: none"> Ensure that the return and/or discharge air paths are not blocked by curtains, blinds, furniture, etc.
	<ul style="list-style-type: none"> Windows or doors to the outside are open. 	<ul style="list-style-type: none"> Ensure that all windows and doors are closed.
	<ul style="list-style-type: none"> The temperature is not set at a cool enough/warm enough setting. 	<ul style="list-style-type: none"> Adjust the Temperature control to a cooler or warmer setting as necessary.
	<ul style="list-style-type: none"> The filter is dirty or obstructed. 	<ul style="list-style-type: none"> Clean the filter, (see Routine Maintenance), or remove obstruction.
	<ul style="list-style-type: none"> The indoor coil or outdoor coil is dirty or obstructed. 	<ul style="list-style-type: none"> Clean the coils, (see Routine Maintenance), or remove obstruction.
	<ul style="list-style-type: none"> There is excessive heat or moisture (cooking, showers, etc.) in the room. 	<ul style="list-style-type: none"> Be sure to use exhaust vent fans while cooking or bathing and, if possible, try not to use heat producing appliances during the hottest part of the day.
	<ul style="list-style-type: none"> The temperature of the room you are trying to cool is extremely hot. 	<ul style="list-style-type: none"> Allow additional time for the air conditioner to cool off a very hot room.

M. TROUBLESHOOTING

M.1. Troubleshooting Tips (Cont)

COMPLAINT	CAUSE	SOLUTION
Unit Does Not Cool/ Heat Room Sufficiently, or Cycles On And Off Too Frequently (continued).	<ul style="list-style-type: none"> The outside temperature is below 60 °F (16 °C). 	<ul style="list-style-type: none"> Do not try to operate your air conditioner in the cooling mode when the outside temperature is below 60 °F (16 °C). The unit will not cool properly, and the unit may be damaged.
	<ul style="list-style-type: none"> The digital control is set to fan cycling mode. 	<ul style="list-style-type: none"> Since the fan does not circulate the room air continuously at this setting, the room air does not mix as well and hot (or cold) spots may result. Using the continuous fan setting is recommended to obtain optimum comfort levels.
	<ul style="list-style-type: none"> The air conditioner has insufficient cooling capacity to match the heat gain of the room. 	<ul style="list-style-type: none"> Check the cooling capacity of your unit to ensure it is properly sized for the room in which it is installed. Room air conditioners are not designed to cool multiple rooms.
	<ul style="list-style-type: none"> The air conditioner has insufficient heating capacity to match the heat loss of the room. 	<ul style="list-style-type: none"> Check the heating capacity of your unit. Air conditioners are sized to meet the cooling load, and heater size is then selected to meet the heating load. In extreme northern climates, room air conditioners may not be able to be used as a primary source of heat.
Unit Runs Too Much.	<ul style="list-style-type: none"> This may be due to an excessive heat load in the room. 	<ul style="list-style-type: none"> If there are heat producing appliances in use in the room, or if the room is heavily occupied, the unit will need to run longer to remove the additional heat.
	<ul style="list-style-type: none"> It may also be due to an improperly sized unit. 	<ul style="list-style-type: none"> Be sure to use exhaust vent fans while cooking or bathing and, if possible, try not to use heat producing appliances during the hottest part of the day.
	<ul style="list-style-type: none"> This may be normal for higher efficiency (EER) air conditioners. 	<ul style="list-style-type: none"> The use of higher efficiency components in your new air conditioner may result in the unit running longer than you feel it should. This may be more apparent, if it replaced an older, less efficient, model. The actual energy usage, however, will be significantly less when compared to older models.
	<ul style="list-style-type: none"> You may notice that the discharge air temperature of your new air conditioner may not seem as cold as you may be accustomed to from older units. This does not, however, indicate a reduction in the cooling capacity of the unit. 	<ul style="list-style-type: none"> The energy efficiency ratio (EER) and cooling capacity rating (Btu/h) listed on the unit's rating plate are both agency certified.

M.2 Diagnostic Codes

DIAG CODE	PROBLEM	CONTROL BOARD'S ACTION
1	Front Panel Button Stuck For More Than 20 Seconds	Continue to monitor for "OPEN" (Unstuck) switch. Do not process switch input. ENSURE FRONT COVER DOES NOT DEPRESS BUTTONS
3	Indoor Temperature Sensor is Open or Shorted	Set temp to 75°F in COOLING or 68°F in HEATING. Unit continues to operate
4	Indoor Coil Temperature Sensor is Open or Shorted	Control Board sets temp to a default of 40°F. Override sensor. Unit continues to operate.
5	Outdoor Coil Temperature Sensor is Open or Shorted	Sets temp to 20°F. Override sensor. Continue operation. Use Electric Heat if available for HEATING. If not available use HEAT PUMP if outdoor temp allows.
6	Outdoor Coil greater than 175° F	Turn Compressor off. Wait for the outdoor coil to be less than 150°F for more than 2 consecutive minutes.
7	Indoor Coil less than 30° F for 2 consecutive minutes	Turn compressor and electric heat off. When coil temp reaches 45°F resume operation after lockout time.
8	Unit Cycles greater than 9 Times per hour	Continue operation. Continue to monitor. Take no action. Log Only.
9	Unit Cycles less than 3 Times per Hour	Continue operation. Continue to monitor. Take no action. Log Only.

M. TROUBLESHOOTING

M.2 Diagnostic Codes (Cont.)

12	Discharge Air greater than 185°F	Shutdown electric heater. Wait for the discharge air temperature to be less than 100°F. Resume operation.
13	High Pressure Switch Open	Turn compressor off. Wait until pressure switch is no longer open. Resume operation after lockout time.
14	Discharge Air Temperature Sensor is Open or Shorted	Override Sensor. Set temp to 75°F. Continue to monitor. Set error code 14 ON.
15	Inverter communication lost	No communication with inverter board
16	Temperature Beyond Operating Limits	Ambient temp is less than 0°F or greater than 130°F. Turn off compressor, electric heat, and fan. When cleared resume operation.
17	Inverter fan fault	Fan faults from inverter
18	Inverter immediate fault 1	First group of immediate faults.
19	Inverter immediate fault 2	Second group of immediate faults.
20	Inverter controlled fault 1	First group of controlled faults.
21	Inverter controlled fault 2	Second group of controlled faults
22	Outdoor Coil Temperature less than 30°F for 2 consecutive Minutes	Only applicable to units with heat pump and electric heat. Turn off heat pump operation. Use electric heat to satisfy all heating demands. Cleared when outdoor coil temp is greater than 45°F.
23	Frost Protection.	Only applicable to heat pump only units. Active when Heat Pump run time exceeds 60 minutes with the outdoor coil temp less than 26°F. Runs active defrost for up to 6 minutes.

P. Appendixes

P.1 Accessories and Options

DC-2 Drain Kit - Part No. 01900235

In some installations, excess condensate water caused by extremely humid conditions, may result in an undesirable water drip such as on a patio or over an entryway. MODEL DC-2 DRAIN KIT (Part No. 01900-235) can be installed to drain excess condensation to an alternate location.

Window Installation Kits (Standard in Kühl Models without Heat)

KWIKS – For all KEVS and KHVS models.

KWIKM – For all KEVM and KHVM models.

KWIKL – For all KEVL and KHVL models.

See www.friedrich.com for additional accessories for your unit.

R . INFORMATION FOR THE OWNER

Present the owner or operator of the equipment with the Installation & Operation Manual, all accessory installation instructions, and the name, address, and telephone number of the Authorized Friedrich Warranty Service Company in the area for future reference if necessary. Inspect the unit for any damage to the coils and tubing that could cause a leak.

R.1 Room air conditioner unit performance test data sheet

Job name _____		
Tech's name _____		
Date _____		
Model# _____ serial # _____		
Check the installation	acceptable Yes	not acceptable no
Is a chassis gasket installed?	_____	_____
Is the fresh / exhaust air vent open?	_____	_____
Is a Friedrich sleeve installed?	_____	_____
Is a Friedrich outdoor grille installed?	_____	_____
Is maintenance being performed?	_____	_____
Electrical		
Line voltage (static)	_____	volts
Start up voltage	_____	volts
Amperage draw (cool)	_____	amps
Amperage draw (heat)	_____	amps
Compressor		
Locked rotor amps	_____	amps
Running amperage draw	_____	amps
Indoor conditions		
Indoor ambient temperature	_____	f
Relative humidity (rh) indoor	_____	%
Discharge air temperature (indoor)(cool)	_____	f
Discharge air temperature (indoor)(heat)	_____	f
Return air temperature (indoor)(cool)	_____	f
Return air temperature (indoor) (heat)	_____	f
Outdoor temperature		
Outdoor ambient temperature	_____	f
Rh outdoor relative humidity	_____	%
Discharge air temperature (outdoor)(cool)	_____	f
Discharge air temperature (outdoor)(heat)	_____	f
Intake air temperature (outdoor)(cool)	_____	f
Intake air temperature (outdoor)(heat)	_____	f
Cooling or heating area		
Area w _____ * l _____ = feet squared		
For a general guide refer to sizing guide to the right		
For exact load calculations consult manual j or m.		

R.2 Routine Maintenance

Decorative Front

Use a damp (not wet) cloth when cleaning the control area to prevent water from entering the unit, and possibly damaging the electronic control.

The decorative front and the cabinet can be cleaned with warm water and a mild liquid detergent. Do NOT use solvents or hydrocarbon based cleaners such as acetone, naphtha, gasoline, benzene, etc.

The indoor coil can be vacuumed with a dusting attachment if it appears to be dirty. DO NOT BEND FINS. The outdoor coil can be gently sprayed with a garden hose.

Air Filter

The air filter should be inspected weekly and cleaned if needed by vacuuming with a dust attachment or by cleaning in the sink using warm water and a mild dishwashing detergent. Dry the filter thoroughly before reinstalling. Use caution, the coil surface can be sharp.

WARNING: Service of this product (aside from filter maintenance) shall only be performed by trained service personnel. Refer to the Service Manual for procedures on how to inspect and maintain the interior of the unit and its components. A QR code is located in section A.5 which will help you locate the service manual online.



Coils & Chassis

The indoor coil and outdoor coils and base pan should be inspected periodically (annually or semi-annually) and cleaned of all debris (lint, dirt, leaves, paper, etc.) as necessary. Under extreme conditions, more frequent cleaning may be required.

Wall Sleeve

Inspect the inside of the wall sleeve and drain system periodically (annually or semi-annually) and clean as required. Under extreme conditions, more frequent cleaning may be necessary.

Blower Wheel / Housing / Condenser Fan / Shroud

Inspect the indoor blower and its housing, evaporator blade, condenser fan blade and condenser shroud periodically (yearly or bi-yearly) and clean of all debris (lint, dirt, mold, fungus, etc.).

PTAC Direct Sales, Inc.
185 S. Kimball Ave., Suite 130
Southlake, TX 76092
877.454.7822 (T)
877.647.6408 (F)

www.PTACdirect.com