



# Service Manual

## Indoor Unit:

LIV09HP115V1R32AH  
LIV12HP115V1R32AH

LIV09HP230V1R32AH  
LIV12HP230V1R32AH  
LIV18HP230V1R32AH  
LIV24HP230V1R32AH  
LIV30HP230V1R32AH  
LIV36HP230V1R32AH

## Outdoor Unit:





LIV09HP115V1R32AO  
LIV12HP115V1R32AO

LIV09HP230V1R32AO  
LIV12HP230V1R32AO  
LIV18HP230V1R32AO  
LIV24HP230V1R32AO  
LIV30HP230V1R32AO  
LIV36HP230V1R32AO

# Table of Contents

<b>Part I : Technical Information .....</b>	<b>2</b>
<b>1. Summary .....</b>	<b>2</b>
<b>2. Specifications .....</b>	<b>4</b>
2.1 Specification Sheet.....	4
2.2 Capacity Variation Ratio According to Temperature .....	30
2.3 Cooling and Heating Data Sheet in Rated Frequency.....	30
<b>3. Outline Dimension Diagram .....</b>	<b>32</b>
3.1 Indoor Unit.....	32
3.2 Outdoor Unit.....	33
<b>4. Refrigerant System Diagram .....</b>	<b>36</b>
<b>5. Electrical Part.....</b>	<b>38</b>
5.1 Wiring Diagram .....	38
5.2 PCB Printed Diagram.....	43
<b>6. Function and Control .....</b>	<b>52</b>
6.1 Remote Controller Introduction .....	52
6.2 GREE+ App Operation Manual .....	61
6.3 Ewpe Smart App Operation Manual.....	62
6.4 Brief Description of Models and Functions .....	63
<b>Part II : Installation and Maintenance .....</b>	<b>70</b>
<b>7. Notes for Installation and Maintenance.....</b>	<b>70</b>
<b>8. Installation.....</b>	<b>77</b>
8.1 Installation Dimension Diagram.....	77
8.2 Installation Parts-checking .....	79
8.3 Selection of Installation Location.....	79
8.4 Electric Connection Requirement .....	79
8.5 Installation of Indoor Unit.....	80

8.6 Installation of Outdoor unit.....	82
8.7 Vacuum Pumping and Leak Detection.....	84
8.8 Check after Installation and Test operation.....	84
<b>9. Maintenance.....</b>	<b>85</b>
9.1 Error Code List.....	85
9.2 Procedure of Troubleshooting .....	90
9.3 Troubleshooting for Normal Malfunction .....	102
<b>10. Exploded View and Parts List .....</b>	<b>104</b>
10.1 Indoor Unit.....	104
10.2 Outdoor Unit .....	116
<b>11. Removal Procedure .....</b>	<b>128</b>
11.1 Removal Procedure of Indoor Unit.....	128
11.2 Removal Procedure of Outdoor Unit.....	133
<b>Appendix .....</b>	<b>155</b>
Appendix 1: Reference Sheet of Celsius and Fahrenheit.....	155
Appendix 2: Configuration of Connection Pipe .....	155
Appendix 3: Pipe Expanding Method.....	156
Appendix 4: List of Resistance for Temperature Sensor.....	157

Symbol	Explanation
	<p>This symbol shows that this appliance uses a flammable refrigerant. If the refrigerant is leaked and exposed to an external ignition source, there is a risk of fire.</p> <p>Appliance filled with flammable magas R32</p>
	<p>This symbol shows that the operation manual should be read carefully.</p>
	<p>This symbol shows that information is available such as the operating manual or installation manual.</p>
	<p>This symbol shows that a service personnel should be handling this equipment with reference to the installation manual.</p>

# 1. Summary

## Indoor Unit:



## Outdoor Unit:

LIV09HP115V1R32AO  
LIV12HP115V1R32AO  
LIV09HP230V1R32AO  
LIV12HP230V1R32AO

LIV18HP230V1R32AO



LIV30HP230V1R32AO  
LIV36HP230V1R32AO

LIV24HP230V1R32AO

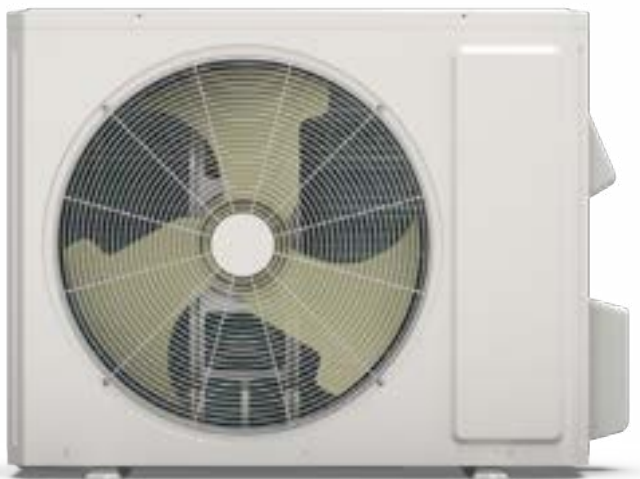

## Remote Controller:

YAY1FF



YBE1FB1F



## Model list:

No	Model	Product code	Indoor model	Indoor product code	Outdoor model	Outdoor product code	Remote Controller
1	GWC09ATCXB-A6DNA1B	CB574015400	GWC09ATCXB-A6DNA1B/I	CB574N15400	GWC09ATCXB-A6DNA1B/O	CB574W15400	YAY1FF
2	GWH09ATCXB-A6DNA1B	CB574017300	GWH09ATCXB-A6DNA1B/I	CB574N17300	GWH09ATCXB-A6DNA1B/O	CB574W17300	
3	GWC09ATCXB-D6DNA1B	CB574014800	GWC09ATCXB-D6DNA1B/I	CB574N14800	GWC09ATCXB-D6DNA1B/O	CB574W14800	
4	GWC09ATCXB-D6DNA4B	CB595007400	GWC09ATCXB-D6DNA4B/I	CB595N07400	GWC09ATCXB-D6DNA1B/O	CB574W14800	
5	GWH09ATCXB-D6DNA1B	CB574017200	GWH09ATCXB-D6DNA1B/I	CB574N17200	GWH09ATCXB-D6DNA1B/O	CB574W17200	
6	GWC12ATCXD-A6DNA1A	CB574014200	GWC12ATCXD-A6DNA1A/I	CB574N14200	GWC12ATCXD-A6DNA1A/O	CB574W14200	
7	GWC12ATCXD-A6DNA4A	CB595007600	GWC12ATCXD-A6DNA4A/I	CB595N07600	GWC12ATCXD-A6DNA1A/O	CB574W14200	
8	GWH12ATCXD-A6DNA1B	CB574017000	GWH12ATCXD-A6DNA1B/I	CB574N17000	GWH12ATCXD-A6DNA1B/O	CB574W17000	
9	GWC12ATCXD-D6DNA1A	CB574013800	GWC12ATCXD-D6DNA1A/I	CB574N13800	GWC12ATCXD-D6DNA1A/O	CB574W13800	
10	GWC12ATCXD-D6DNA4A	CB595007500	GWC12ATCXD-D6DNA4A/I	CB595N07500	GWC12ATCXD-D6DNA1A/O	CB574W13800	
11	GWH12ATCXD-D6DNA1B	CB574017100	GWH12ATCXD-D6DNA1B/I	CB574N17100	GWH12ATCXD-D6DNA1B/O	CB574W17100	
12	GWC18ATDXD-D6DNA1C	CB574013900	GWC18ATDXD-D6DNA1C/I	CB574N13900	GWC18ATDXD-D6DNA1C/O	CB574W13900	
13	GWC18ATDXD-D6DNA4C	CB595007700	GWC18ATDXD-D6DNA4C/I	CB595N07700	GWC18ATDXD-D6DNA1C/O	CB574W13900	
14	GWH18ATDXE-D6DNA1C	CB574018900	GWH18ATDXE-D6DNA1C/I	CB574N18900	GWH18ATDXE-D6DNA1C/O	CB574W18900	
15	GWC24ATEXE-D6DNA1A	CB574014600	GWC24ATEXE-D6DNA1A/I	CB574N14600	GWC24ATEXE-D6DNA1A/O	CB574W14600	
16	GWC24ATEXE-D6DNA4A	CB595007300	GWC24ATEXE-D6DNA4A/I	CB595N07300	GWC24ATEXE-D6DNA1A/O	CB574W14600	
17	GWH24ATEXF-D6DNA1G	CB574018000	GWH24ATEXF-D6DNA1G/I	CB574N18000	GWH24ATEXF-D6DNA1G/O	CB574W18000	
18	GWC36ATEXH-D6DNA1G	CB574018200	GWC36ATEXH-D6DNA1G/I	CB574N18200	GWC36ATEXH-D6DNA1G/O	CB574W18200	
19	<b>LIV36HP230V1R32AO</b>	CB574018100	GWH36ATEXH-D6DNA1G/I	CB574N18100	GWH36ATEXH-D6DNA1G/O	CB574W18100	
20	GWC09ATCXB-A6DNA1C	CB574016900	GWC09ATCXB-A6DNA1C/I	CB574N16900	GWC09ATCXB-A6DNA1C/O	CB574W16900	YBE1FB1F
21	<b>LIV09HP115V1R32AO</b>	CB574016700	GWH09ATCXB-A6DNA1C/I	CB574N16700	GWH09ATCXB-A6DNA1C/O	CB574W16700	
22	GWC09ATCXB-D6DNA1C	CB574016800	GWC09ATCXB-D6DNA1C/I	CB574N16800	GWC09ATCXB-D6DNA1C/O	CB574W16800	
23	<b>LIV09HP230V1R32AO</b>	CB574016600	GWH09ATCXB-D6DNA1C/I	CB574N16600	GWH09ATCXB-D6DNA1C/O	CB574W16600	
24	GWC12ATCXB-A6DNA1A	CB574016500	GWC12ATCXB-A6DNA1A/I	CB574N16500	GWC12ATCXB-A6DNA1A/O	CB574W16500	
25	<b>LIV12HP115V1R32AO</b>	CB574018500	GWH12ATCXB-A6DNA1A/I	CB574N18500	GWH12ATCXB-A6DNA1A/O	CB574W18500	
26	GWC12ATCXB-D6DNA1A	CB574016200	GWC12ATCXB-D6DNA1A/I	CB574N16200	GWC12ATCXB-D6DNA1A/O	CB574W16200	
27	<b>LIV12HP230V1R32AO</b>	CB574018400	GWH12ATCXB-D6DNA1A/I	CB574N18400	GWH12ATCXB-D6DNA1A/O	CB574W18400	
28	GWC18ATDXD-D6DNA1A	CB574017600	GWC18ATDXD-D6DNA1A/I	CB574N17600	GWC18ATDXD-D6DNA1A/O	CB574W17600	
29	<b>LIV18HP230V1R32AO</b>	CB574017700	GWH18ATDXD-D6DNA1A/I	CB574N17700	GWH18ATDXD-D6DNA1A/O	CB574W17700	
30	<b>LIV24HP230V1R32AO</b>	CB574017900	GWC24ATEXF-D6DNA1F/I	CB574N17900	GWC24ATEXF-D6DNA1F/O	CB574W17900	
31	GWH24ATEXF-D6DNA1F	CB574017800	GWH24ATEXF-D6DNA1F/I	CB574N17800	GWH24ATEXF-D6DNA1F/O	CB574W17800	

# 2. Specifications

## 2.1 Specification Sheet

Model			GWC09ATCXB-A6DNA1B	LIV09HP115V1R32A
Product Code			CB574015400	CB574017300
Power Supply	Rated Voltage	V~	115	115
	Rated Frequency	Hz	60	60
	Phases		1	1
Power Supply Mode		--	Outdoor	Outdoor
Cooling Capacity		Btu/h	9100	9100
Heating Capacity		Btu/h	/	9700
Cooling Power Input		W	740	740
Heating Power Input		W	/	770
Cooling Current Input		A	8	8.2
Heating Current Input		A	/	8.8
Rated Input		W	1100	1200
Rated Cooling Current		A	11.6	14.5
Rated Heating Current		A	/	14
Air Flow Volume		CFM	353/282/265/230/212/194/159/124	353/282/265/230/212/194/159/124
Dehumidifying Volume		Pint/h	1.69	1.69
EER2		(Btu/h)/W	12.3	12.3
COP2		(Btu/h)/W	/	12.6
SEER2		--	21	21
HSPF2		--	/	8.6
Application Area		yd <sup>2</sup>	14-21	14-21
Indoor Unit	Model		GWC09ATCXB-A6DNA1B/I	LIV09HP115V1R32AH
	Product Code		CB574N15400	CB574N17300
	Fan Type		Cross-flow	Cross-flow
	Fan Diameter Length(DXL)	mm	Φ94×630	Φ94×630
	Cooling Speed	r/min	1250/1100/1050/950/800/700/650/500	1250/1100/1050/950/800/700/650/500
	Heating Speed	r/min	/	1250/1100/1040/950/900/880/850
	Fan Motor Power Output	W	35	35
	Fan Motor RLA	A	0.35	0.4
	Fan Motor Capacitor	μF	/	/
	Evaporator Form	--	Aluminum Fin-copper Tube	Aluminum Fin-copper Tube
	Evaporator Pipe Diameter	mm	Φ5	Φ5
	Evaporator Row-fin Gap	mm	2-1.3	2-1.3
	Evaporator Coil Length (LXDXW)	mm	634×22.8×266.7	634×22.8×266.7
	Swing Motor Model	--	MP24HF	MP24HF
	Swing Motor Power Output	W	1.5	1.5
	Fuse Current	A	3.15	3.15
	Sound Pressure Level	dB (A)	40/36/35/32/28/25/24/21	Cooling:40/36/35/32/27/24/22/20 Heating:40/36/35/32/31/30/29
	Sound Power Level	dB (A)	50/46/45/42/38/35/34/31	Cooling:50/46/45/42/37/34/32/30 Heating:50/46/45/42/41/40/39
	Dimension (WXHxD)	inch	32 7/8X10 53/64X7 7/8	32 7/8X10 53/64X7 7/8
	Dimension of Carton Box (LXWXH)	inch	35 3/64X12 61/64X10 15/64	35 3/64X12 61/64X10 15/64
Dimension of Package (LXWXH)	inch	35 15/64X13 37/64X10 43/64	35 15/64X13 37/64X10 43/64	
Net Weight	lb	18.7	18.7	
Gross Weight	lb	23.2	23.2	

Outdoor Unit	Outdoor Unit Model	--	GWC09ATCXB-A6DNA1B/O	<b>LIV09HP115V1R32AO</b>
	Outdoor Unit Product Code	--	CB574W15400	CB574W17300
	Compressor Manufacturer	--	ZHUHAI LANDA COMPRESSOR CO.,LTD	ZHUHAI LANDA COMPRESSOR CO.,LTD
	Compressor Model	--	QXF-N075zC170A	QXF-N075zC170A
	Compressor Oil	--	FW68DA or equivalent	FW68DA or equivalent
	Compressor Type	--	Rotary	Rotary
	Compressor LRA.	A	/	/
	Compressor RLA	A	10.7	13.85
	Compressor Power Input	W	640	640
	Compressor Overload Protector	--	/	/
	Throttling Method	--	Capillary	Capillary
	Set Temperature Range	°F	61~86	61~86
	Cooling Operation Ambient Temperature Range	°F	-4~122	-4~122
	Heating Operation Ambient Temperature Range	°F	/	-13~75
	Condenser Form	--	Aluminum Fin-copper Tube	Aluminum Fin-copper Tube
	Condenser Pipe Diameter	mm	Φ7	Φ7
	Condenser Rows-fin Gap	mm	1-1.2	1-1.2
	Condenser Coil Length (LXDXW)	mm	677×19.05×528	677×19.05×528
	Fan Motor Speed	rpm	850	850
	Fan Motor Power Output	W	30	30
	Fan Motor RLA	A	0.55	0.62
	Fan Motor Capacitor	μF		
	Outdoor Unit Air Flow Volume	m <sup>3</sup> /h	1950	1950
	Fan Type	--	Axial-flow	Axial-flow
	Fan Diameter	mm	Φ400	Φ400
	Defrosting Method	--	/	Automatic Defrosting
	Climate Type	--	T1	T1
	Isolation	--	I	I
	Moisture Protection	--	IPX4	IPX4
	Permissible Excessive Operating Pressure for the Discharge Side	MPa	4.3	4.3
	Permissible Excessive Operating Pressure for the Suction Side	MPa	2.5	2.5
	Sound Pressure Level	dB (A)	51	51
	Sound Power Level	dB (A)	61	61
Dimension(WXHxD)	inch	28 13/16X21 27/32X12 63/64	28 13/16X21 27/32X12 63/64	
Dimension of Carton Box (LXWXH)	inch	31 9/64X14 11/16X23 15/64	31 9/64X14 11/16X23 15/64	
Dimension of Package(LXWXH)	inch	31 17/64X14 51/64X24 7/32	31 17/64X14 51/64X24 7/32	
Net Weight	lb	56.2	58.4	
Gross Weight	lb	61.7	63.9	
Refrigerant	--	R32	R32	
Refrigerant Charge	oz	19.8	19.8	
Connection Pipe	Connection Pipe Length	ft	24.6	24.6
	Connection Pipe Gas Additional Charge	oz/ft.	0.1	0.2
	Outer Diameter Liquid Pipe		1/4"	1/4"
	Outer Diameter Gas Pipe		3/8"	3/8"
	Max Distance Height	ft	32.8	32.8
	Max Distance Length	ft	49.2	49.2
Note: The connection pipe applies metric diameter.				

The above data is subject to change without notice. Please refer to the nameplate of the unit.

Model			GWC09ATCXB-D6DNA1B GWC09ATCXB-D6DNA4B	LIV09HP230V1R32A
Product Code			CB574014800 CB595007400	CB574017200
Power Supply	Rated Voltage	V~	208/230	208/230
	Rated Frequency	Hz	60	60
	Phases		1	1
Power Supply Mode		--	Outdoor	Outdoor
Cooling Capacity		Btu/h	9100	9100
Heating Capacity		Btu/h	/	9800
Cooling Power Input		W	752	752
Heating Power Input		W	/	810
Cooling Current Input		A	3.8	3.8
Heating Current Input		A	/	/
Rated Input		W	1200	1250
Rated Cooling Current		A	6	6
Rated Heating Current		A	/	6.5
Air Flow Volume		CFM	353/282/265/230/212/194/159/124	353/282/265/230/212/194/159/124
Dehumidifying Volume		Pint/h	1.69	1.69
EER2		(Btu/h)/W	12.1	12.1
COP2		(Btu/h)/W	/	12.1
SEER2		--	21	21
HSPF2		--	/	8.6
Application Area		yd <sup>2</sup>	14-21	14-21
Indoor Unit	Model		GWC09ATCXB-D6DNA1B/I GWC09ATCXB-D6DNA4B/I	LIV09HP230V1R32AH
	Product Code		CB574N14800 CB595N07400	CB574N17200
	Fan Type		Cross-flow	Cross-flow
	Fan Diameter Length(DXL)	mm	Φ94×630	Φ94×630
	Cooling Speed	r/min	1250/1100/1050/950/800/700/650/500	1250/1100/1050/950/800/700/650/500
	Heating Speed	r/min	/	1250/1100/1040/950/900/880/850
	Fan Motor Power Output	W	55	55
	Fan Motor RLA	A	0.35	0.35
	Fan Motor Capacitor	μF	/	/
	Evaporator Form	--	Aluminum Fin-copper Tube	Aluminum Fin-copper Tube
	Evaporator Pipe Diameter	mm	Φ5	Φ5
	Evaporator Row-fin Gap	mm	2-1.3	2-1.3
	Evaporator Coil Length (LXDXW)	mm	634×22.8×266.7	634×22.8×266.7
	Swing Motor Model	--	MP24HF	MP24HF
	Swing Motor Power Output	W	1.5	1.5
	Fuse Current	A	3.15	3.15
	Sound Pressure Level	dB (A)	40/36/35/32/28/25/24/21	Cooling:42/39/37/36/28/25/23/21 Heating:40/35/34/32/31/30/29
	Sound Power Level	dB (A)	50/46/45/42/38/35/34/31	Cooling:52/49/47/46/38/35/33/31 Heating:50/45/44/42/41/40/39
	Dimension (WXHxD)	inch	32 7/8X10 53/64X7 7/8	32 7/8X10 53/64X7 7/8
	Dimension of Carton Box (LXWXH)	inch	35 3/64X12 61/64X10 15/64	35 3/64X12 61/64X10 15/64
Dimension of Package (LXWXH)	inch	35 15/64X13 37/64X10 43/64	35 15/64X13 37/64X10 43/64	
Net Weight	lb	18.7	18.7	
Gross Weight	lb	23.2	23.2	



Outdoor Unit	Outdoor Unit Model	--	GWC09ATCXB-D6DNA1B/O	<b>LIV09HP230V1R32AO</b>
	Outdoor Unit Product Code	--	CB574W14800	CB574W17200
	Compressor Manufacturer	--	ZHUHAI LANDA COMPRESSOR CO.,LTD	ZHUHAI LANDA COMPRESSOR CO.,LTD
	Compressor Model	--	QXF-A082zC170	QXF-A082zC170
	Compressor Oil	--	ZE-GLES RB68GX or equivalent	ZE-GLES RB68GX or equivalent
	Compressor Type	--	Rotary	Rotary
	Compressor LRA.	A	/	/
	Compressor RLA	A	6.4	6.4
	Compressor Power Input	W	756.6	756.6
	Compressor Overload Protector	--	/	/
	Throttling Method	--	Capillary	Capillary
	Set Temperature Range	°F	61~86	61~86
	Cooling Operation Ambient Temperature Range	°F	-4~122	-4~122
	Heating Operation Ambient Temperature Range	°F	/	-13~75
	Condenser Form	--	Aluminum Fin-copper Tube	Aluminum Fin-copper Tube
	Condenser Pipe Diameter	mm	Φ7	Φ7
	Condenser Rows-fin Gap	mm	1-1.2	1-1.2
	Condenser Coil Length (LXD <sub>X</sub> W)	mm	677×19.05×528	677×19.05×528
	Fan Motor Speed	rpm	850	850
	Fan Motor Power Output	W	30	30
	Fan Motor RLA	A	0.65	0.65
	Fan Motor Capacitor	μF	/	/
	Outdoor Unit Air Flow Volume	m <sup>3</sup> /h	1950	1950
	Fan Type	--	Axial-flow	Axial-flow
	Fan Diameter	mm	Φ400	Φ400
	Defrosting Method	--	/	Automatic Defrosting
	Climate Type	--	T1	T1
	Isolation	--	I	I
	Moisture Protection	--	IPX4	IPX4
	Permissible Excessive Operating Pressure for the Discharge Side	MPa	4.3	4.3
	Permissible Excessive Operating Pressure for the Suction Side	MPa	2.5	2.5
	Sound Pressure Level	dB (A)	50	50
	Sound Power Level	dB (A)	60	60
Dimension(WXHXD)	inch	28 13/16X21 27/32X12 63/64	28 13/16X21 27/32X12 63/64	
Dimension of Carton Box (LXWXH)	inch	31 9/64X14 11/16X23 15/64	31 9/64X14 11/16X23 15/64	
Dimension of Package(LXWXH)	inch	31 17/64X14 51/64X24 7/32	31 17/64X14 51/64X24 7/32	
Net Weight	lb	51.8	55.1	
Gross Weight	lb	57.3	60.6	
Refrigerant	--	R32	R32	
Refrigerant Charge	oz	19.8	19.8	
Connection Pipe	Connection Pipe Length	ft	24.6	24.6
	Connection Pipe Gas Additional Charge	oz/ft.	0.1	0.2
	Outer Diameter Liquid Pipe		1/4"	1/4"
	Outer Diameter Gas Pipe		3/8"	3/8"
	Max Distance Height	ft	32.8	32.8
	Max Distance Length	ft	49.2	49.2
Note: The connection pipe applies metric diameter.				

The above data is subject to change without notice. Please refer to the nameplate of the unit.

Model			GWC12ATCXD-A6DNA1A GWC12ATCXD-A6DNA4A	GWH12ATCXD-A6DNA1B
Product Code			CB574014200 CB595007600	CB574017000
Power Supply	Rated Voltage	V~	115	115
	Rated Frequency	Hz	60	60
	Phases		1	1
Power Supply Mode		--	Outdoor	Outdoor
Cooling Capacity		Btu/h	12000	12000
Heating Capacity		Btu/h	/	12000
Cooling Power Input		W	1091	1091
Heating Power Input		W	/	976
Cooling Current Input		A	12	12
Heating Current Input		A	/	11
Rated Input		W	1400	1450
Rated Cooling Current		A	15	15
Rated Heating Current		A	/	16
Air Flow Volume		CFM	424/353/324/277/247/224/182/165	424/353/324/277/247/224/182/165
Dehumidifying Volume		Pint/h	2.96	2.96
EER2		(Btu/h)/W	11.00	11.00
COP2		(Btu/h)/W	/	12.3
SEER2		--	21.5	21.5
HSPF2		--	/	8.5
Application Area		yd <sup>2</sup>	16-24	16-24
Indoor Unit	Model		GWC12ATCXD-A6DNA1A/I GWC12ATCXD-A6DNA4A/I	GWH12ATCXD-A6DNA1B/I
	Product Code		CB574N14200 CB595N07600	CB574N17000
	Fan Type		Cross-flow	Cross-flow
	Fan Diameter Length(DXL)	mm	Φ94×630	Φ94×630
	Cooling Speed	r/min	1550/1200/1120/1050/980/920/750/500	1550/1200/1120/1050/980/920/750/500
	Heating Speed	r/min	/	1450/1200/1140/1080/1020/960/900
	Fan Motor Power Output	W	15	15
	Fan Motor RLA	A	0.62	0.62
	Fan Motor Capacitor	μF	/	/
	Evaporator Form	--	Aluminum Fin-copper Tube	Aluminum Fin-copper Tube
	Evaporator Pipe Diameter	mm	Φ5	Φ5
	Evaporator Row-fin Gap	mm	2-1.3	2-1.3
	Evaporator Coil Length (LXDXW)	mm	634×22.8×266.7	634×22.8×266.7
	Swing Motor Model	--	MP24HF	MP24HF
	Swing Motor Power Output	W	1.5	1.5
	Fuse Current	A	3.15	3.15
	Sound Pressure Level	dB (A)	45/37/36/34/32/31/24/23	Cooling:45/37/36/34/33/31/24/23 Heating:45/38/36/35/33/31/30
	Sound Power Level	dB (A)	55/47/46/44/42/41/34/33	Cooling:55/47/46/44/43/41/34/33 Heating:55/48/46/45/43/41/40
	Dimension (WXHxD)	inch	32 7/8X10 53/64X7 7/8	32 7/8X10 53/64X7 7/8
	Dimension of Carton Box (LXWXH)	inch	35 3/64X12 61/64X10 15/64	35 3/64X12 61/64X10 15/64
Dimension of Package (LXWXH)	inch	35 15/64X13 37/64X10 43/64	35 15/64X13 37/64X10 43/64	
Net Weight	lb	19.8	19.8	
Gross Weight	lb	24.3	24.3	

Outdoor Unit	Outdoor Unit Model	--	GWC12ATCXD-A6DNA1A/O	GWH12ATCXD-A6DNA1B/O
	Outdoor Unit Product Code	--	CB574W14200	CB574W17000
	Compressor Manufacturer	--	ZHUHAI LANDA COMPRESSOR CO.,LTD	ZHUHAI LANDA COMPRESSOR CO.,LTD
	Compressor Model	--	QXF-M098zE170	QXF-M098zE170
	Compressor Oil	--	FW68L	FW68L
	Compressor Type	--	Rotary	Rotary
	Compressor LRA.	A	/	/
	Compressor RLA	A	12.17	13.7
	Compressor Power Input	W	844	844
	Compressor Overload Protector	--	/	/
	Throttling Method	--	Electron expansion valve	Electron expansion valve
	Set Temperature Range	°F	61~86	61~86
	Cooling Operation Ambient Temperature Range	°F	-4~122	-4~122
	Heating Operation Ambient Temperature Range	°F	/	-13~75
	Condenser Form	--	Aluminum Fin-copper Tube	Aluminum Fin-copper Tube
	Condenser Pipe Diameter	mm	Φ7	Φ7
	Condenser Rows-fin Gap	mm	1-1.2	1-1.2
	Condenser Coil Length (LXDXW)	mm	799.5×19.05×528	799.5×19.05×528
	Fan Motor Speed	rpm	850	850
	Fan Motor Power Output	W	30	30
	Fan Motor RLA	A	0.8	0.89
	Fan Motor Capacitor	μF	/	/
	Outdoor Unit Air Flow Volume	m <sup>3</sup> /h	2200	2200
	Fan Type	--	Axial-flow	Axial-flow
	Fan Diameter	mm	420	420
	Defrosting Method	--	/	Automatic Defrosting
	Climate Type	--	T1	T1
	Isolation	--	I	I
	Moisture Protection	--	IPX4	IPX4
	Permissible Excessive Operating Pressure for the Discharge Side	MPa	4.3	4.3
	Permissible Excessive Operating Pressure for the Suction Side	MPa	2.5	2.5
	Sound Pressure Level	dB (A)	52	53
	Sound Power Level	dB (A)	62	63
	Dimension(WXHxD)	inch	31 37/64X21 27/32X13 25/32	31 37/64X21 27/32X13 25/32
Dimension of Carton Box (LXWXH)	inch	34 7/32X15 35/64X23 25/64	34 7/32X15 35/64X23 25/64	
Dimension of Package(LXWXH)	inch	34 21/64X15 43/64X24 13/32	34 21/64X15 43/64X24 13/32	
Net Weight	lb	62.8	63.9	
Gross Weight	lb	68.4	69.5	
Refrigerant	--	R32	R32	
Refrigerant Charge	oz	25.4	25.4	
Connection Pipe	Connection Pipe Length	ft	24.6	24.6
	Connection Pipe Gas Additional Charge	oz/ft.	0.1	0.2
	Outer Diameter Liquid Pipe		1/4"	1/4"
	Outer Diameter Gas Pipe		3/8"	3/8"
	Max Distance Height	ft	32.8	32.8
	Max Distance Length	ft	65.6	65.6
Note: The connection pipe applies metric diameter.				

The above data is subject to change without notice. Please refer to the nameplate of the unit.

Model			GWC12ATCXD-D6DNA1A GWC12ATCXD-D6DNA4A	GWH12ATCXD-D6DNA1B
Product Code			CB574013800 CB595007500	CB574017100
Power Supply	Rated Voltage	V~	208/230	208/230
	Rated Frequency	Hz	60	60
	Phases		1	1
Power Supply Mode		--	Outdoor	Outdoor
Cooling Capacity		Btu/h	12000	12000
Heating Capacity		Btu/h	/	12000
Cooling Power Input		W	1088	1088
Heating Power Input		W	/	976
Cooling Current Input		A	5	5
Heating Current Input		A	/	4.71
Rated Input		W	1550	1550
Rated Cooling Current		A	7.25	7.2
Rated Heating Current		A	/	6.5
Air Flow Volume		CFM	424/353/324/277/247/224/182/165	424/353/324/277/247/224/182/165
Dehumidifying Volume		Pint/h	2.96	
EER2		(Btu/h)/W	11.00	11.00
COP2		(Btu/h)/W	/	12.3
SEER2		--	21.5	21.5
HSPF2		--	/	8.5
Application Area		yd <sup>2</sup>	16-24	16-24
Indoor Unit	Model		GWC12ATCXD-D6DNA1A/I GWC12ATCXD-D6DNA4A/I	GWH12ATCXD-D6DNA1B/I
	Product Code		CB574N13800 CB595N07500	CB574N17100
	Fan Type		Cross-flow	Cross-flow
	Fan Diameter Length(DXL)	mm	Φ94×630	Φ94×630
	Cooling Speed	r/min	1550/1200/1120/1050/980/920/750/500	1550/1200/1120/1050/980/920/750/500
	Heating Speed	r/min	/	1450/1200/1140/1080/1020/960/900
	Fan Motor Power Output	W	15	15
	Fan Motor RLA	A	0.7	0.7
	Fan Motor Capacitor	μF	/	/
	Evaporator Form	--	Aluminum Fin-copper Tube	Aluminum Fin-copper Tube
	Evaporator Pipe Diameter	mm	Φ5	Φ5
	Evaporator Row-fin Gap	mm	2-1.3	2-1.3
	Evaporator Coil Length (LXDXW)	mm	634×22.8×266.7	634×22.8×266.7
	Swing Motor Model	--	MP24HF	MP24HF
	Swing Motor Power Output	W	1.5	1.5
	Fuse Current	A	3.15	3.15
	Sound Pressure Level	dB (A)	47/39/37/35/33/31/26/23	Cooling:47/39/37/35/33/31/26/23 Heating:46/39/38/36/34/33/31
	Sound Power Level	dB (A)	57/49/47/45/43/41/36/33	Cooling:57/49/47/45/43/41/36/33 Heating:56/49/48/46/44/43/41
	Dimension (WXHxD)	inch	32 7/8X10 53/64X7 7/8	32 7/8X10 53/64X7 7/8
	Dimension of Carton Box (LXWXH)	inch	35 3/64X12 61/64X10 15/64	35 3/64X12 61/64X10 15/64
Dimension of Package (LXWXH)	inch	35 15/64X13 37/64X10 43/64	35 15/64X13 37/64X10 43/64	
Net Weight	lb	18.7	18.7	
Gross Weight	lb	23.2	23.2	

Outdoor Unit	Outdoor Unit Model	--	GWC12ATCXD-D6DNA1A/O	GWH12ATCXD-D6DNA1B/O
	Outdoor Unit Product Code	--	CB574W13800	CB574W17100
	Compressor Manufacturer	--	ZHUHAI LANDA COMPRESSOR CO.,LTD	ZHUHAI LANDA COMPRESSOR CO.,LTD
	Compressor Model	--	QXF-A098zE170	QXF-A098zE170
	Compressor Oil	--	ZE-GLES RB68GX or equivalent	ZE-GLES RB68GX or equivalent
	Compressor Type	--	Rotary	Rotary
	Compressor LRA.	A	/	/
	Compressor RLA	A	7.1	7.1
	Compressor Power Input	W	/	/
	Compressor Overload Protector	--	/	/
	Throttling Method	--	Electron expansion valve	Electron expansion valve
	Set Temperature Range	°F	61~86	61~86
	Cooling Operation Ambient Temperature Range	°F	-4~122	-4~122
	Heating Operation Ambient Temperature Range	°F	/	-4~75
	Condenser Form	--	Aluminum Fin-copper Tube	Aluminum Fin-copper Tube
	Condenser Pipe Diameter	mm	Φ7	Φ7
	Condenser Rows-fin Gap	mm	1-1.2	1-1.2
	Condenser Coil Length (LXDXW)	mm	799.5×19.05×528	799.5×19.05×528
	Fan Motor Speed	rpm	850	850
	Fan Motor Power Output	W	30	30
	Fan Motor RLA	A	0.7	1
	Fan Motor Capacitor	μF	/	/
	Outdoor Unit Air Flow Volume	m <sup>3</sup> /h	2200	2200
	Fan Type	--	Axial-flow	Axial-flow
	Fan Diameter	mm	420	420
	Defrosting Method	--	/	Automatic Defrosting
	Climate Type	--	T1	T1
	Isolation	--	I	I
	Moisture Protection	--	IPX4	IPX4
	Permissible Excessive Operating Pressure for the Discharge Side	MPa	4.3	4.3
	Permissible Excessive Operating Pressure for the Suction Side	MPa	2.5	2.5
	Sound Pressure Level	dB (A)	52	53
	Sound Power Level	dB (A)	62	63
Dimension(WXHXD)	inch	31 37/64X21 27/32X13 25/32	31 37/64X21 27/32X13 25/32	
Dimension of Carton Box (LXWXH)	inch	34 7/32X15 35/64X23 25/64	34 7/32X15 35/64X23 25/64	
Dimension of Package(LXWXH)	inch	34 21/64X15 43/64X24 13/32	34 21/64X15 43/64X24 13/32	
Net Weight	lb	59.5	59.5	
Gross Weight	lb	65	65	
Refrigerant	--	R32	R32	
Refrigerant Charge	oz	25.4	25.4	
Connection Pipe	Connection Pipe Length	ft	24.6	24.6
	Connection Pipe Gas Additional Charge	oz/ft.	0.1	0.1
	Outer Diameter Liquid Pipe		1/4"	1/4"
	Outer Diameter Gas Pipe		3/8"	3/8"
	Max Distance Height	ft	32.8	32.8
	Max Distance Length	ft	65.6	65.6
Note: The connection pipe applies metric diameter.				

The above data is subject to change without notice. Please refer to the nameplate of the unit.

Model			GWC18ATDXD-D6DNA1C GWC18ATDXD-D6DNA4C	GWH18ATDXE-D6DNA1C
Product Code			CB574013900 CB595007700	CB574018900
Power Supply	Rated Voltage	V~	208/230	208/230
	Rated Frequency	Hz	60	60
	Phases		1	1
Power Supply Mode		--	Outdoor	Outdoor
Cooling Capacity		Btu/h	18000	18000
Heating Capacity		Btu/h	/	18500
Cooling Power Input		W	1538	1525
Heating Power Input		W	/	1390
Cooling Current Input		A	7.2	7.2
Heating Current Input		A	/	6.8
Rated Input		W	2000	2300
Rated Cooling Current		A	10.5	11
Rated Heating Current		A	/	11
Air Flow Volume		CFM	618/553/506/471/430/388/353/306	618/553/506/471/430/388/353/306
Dehumidifying Volume		Pint/h	/	3.80
EER2		(Btu/h)/W	11.70	11.80
COP2		(Btu/h)/W	/	13.31
SEER2		--	21	21.5
HSPF2		--	/	8.5
Application Area		yd <sup>2</sup>	27-40	27-40
Indoor Unit	Model		GWC18ATDXD-D6DNA1C/I GWC18ATDXD-D6DNA4C/I	GWH18ATDXE-D6DNA1C/I
	Product Code		CB574N13900 CB595N07700	CB574N18900
	Fan Type		Cross-flow	Cross-flow
	Fan Diameter Length(DXL)	mm	Φ108×691	Φ108×691
	Cooling Speed	r/min	1350/1200/1120/1050/980/860/750	1350/1200/1120/1050/980/860/750
	Heating Speed	r/min	/	1350/1200/1120/1050/950/850/750
	Fan Motor Power Output	W	50	50
	Fan Motor RLA	A	0.6	0.6
	Fan Motor Capacitor	μF	/	/
	Evaporator Form	--	Aluminum Fin-copper Tube	Aluminum Fin-copper Tube
	Evaporator Pipe Diameter	mm	Φ5	Φ5
	Evaporator Row-fin Gap	mm	2-1.2	2-1.2
	Evaporator Coil Length (LXDXW)	mm	700×22.8×381	700×22.8×381
	Swing Motor Model	--	MP35CJ	MP35CJ
	Swing Motor Power Output	W	2.5	2.5
	Fuse Current	A	3.15	3.15
	Sound Pressure Level	dB (A)	51/47/44/42/40/36/31	Cooling:51/48/46/44/41/37/32 Heating:50/46/44/42/39/35/31
	Sound Power Level	dB (A)	61/57/54/52/50/46/41	Cooling:61/58/56/54/51/47/42 Heating:60/56/54/52/49/45/41
	Dimension (WXHxD)	inch	37 1/8X13 7/64X9 11/16	37 1/8X13 7/64X9 11/16
	Dimension of Carton Box (LXWXH)	inch	39 7/32X15 5/8X12 9/32	39 7/32X15 5/8X12 9/32
Dimension of Package (LXWXH)	inch	39 13/32X15 15/16X12 43/64	39 13/32X15 15/16X12 43/64	
Net Weight	lb	28.7	28.7	
Gross Weight	lb	34.2	34.2	

Outdoor Unit	Outdoor Unit Model	--	GWC18ATDXD-D6DNA1C/O	GWH18ATDXE-D6DNA1C/O
	Outdoor Unit Product Code	--	CB574W13900	CB574W18900
	Compressor Manufacturer	--	ZHUHAI LANDA COMPRESSOR CO., LTD.	ZHUHAI LANDA COMPRESSOR CO.,LTD.
	Compressor Model	--	QXF-A120zH170A	QXF-M130zF170
	Compressor Oil	--	FW68DA or equivalent	FW68DA or equivalent
	Compressor Type	--	Rotary	Rotary
	Compressor LRA.	A	/	/
	Compressor RLA	A	8.5	9.7
	Compressor Power Input	W	1075	1196
	Compressor Overload Protector	--	HPC115/95U1/KSD115°C	
	Throttling Method	--	Electron expansion valve	Electron expansion valve
	Set Temperature Range	°F	61~86	61~86
	Cooling Operation Ambient Temperature Range	°F	-4~122	-4~122
	Heating Operation Ambient Temperature Range	°F	/	-13~75
	Condenser Form	--	Aluminum Fin-copper Tube	Aluminum Fin-copper Tube
	Condenser Pipe Diameter	mm	Φ7.94	Φ7.94
	Condenser Rows-fin Gap	mm	2-1.4	2-1.4
	Condenser Coil Length (LXDXW)	mm	787×38.1×528	865×38.1×528
	Fan Motor Speed	rpm	940	970/880/590
	Fan Motor Power Output	W	30	40
	Fan Motor RLA	A	0.85	1.15
	Fan Motor Capacitor	μF	/	/
	Outdoor Unit Air Flow Volume	m <sup>3</sup> /h	2200	3000
	Fan Type	--	Axial-flow	Axial-flow
	Fan Diameter	mm	420	445
	Defrosting Method	--	/	Automatic Defrosting
	Climate Type	--	T1	T1
	Isolation	--	I	I
	Moisture Protection	--	IPX4	IPX4
	Permissible Excessive Operating Pressure for the Discharge Side	MPa	4.3	4.3
	Permissible Excessive Operating Pressure for the Suction Side	MPa	2.5	2.5
	Sound Pressure Level	dB (A)	55	55
	Sound Power Level	dB (A)	65	65
	Dimension(WXHxD)	inch	31 37/64X21 27/32X13 25/32	34 3/8X21 27/32X14 51/64
Dimension of Carton Box (LXWXH)	inch	34 7/32X15 35/64X23 25/64	37 21/64X16 27/32X23 17/64	
Dimension of Package(LXWXH)	inch	34 21/64X15 43/64X24 13/32	37 7/16X16 31/32X24 13/32	
Net Weight	lb	69.5	82.7	
Gross Weight	lb	76.1	89.3	
Refrigerant	--	R32	R32	
Refrigerant Charge	oz	35.3	35.3	
Connection Pipe	Connection Pipe Length	ft	24.606	24.6
	Connection Pipe Gas Additional Charge	oz/ft.	0.1	0.2
	Outer Diameter Liquid Pipe		1/4"	1/4"
	Outer Diameter Gas Pipe		1/2"	1/2"
	Max Distance Height	ft	32.8	32.8
	Max Distance Length	ft	82	82
Note: The connection pipe applies metric diameter.				

The above data is subject to change without notice. Please refer to the nameplate of the unit.

Model			GWC24ATEXE-D6DNA1A GWC24ATEXE-D6DNA4A	GWH24ATEXF-D6DNA1G
Product Code			CB574014600 CB595007300	CB574018000
Power Supply	Rated Voltage	V~	208/230	208/230
	Rated Frequency	Hz	60	60
	Phases		1	1
Power Supply Mode		--	Outdoor	Outdoor
Cooling Capacity		Btu/h	22500	22000
Heating Capacity		Btu/h	/	24000
Cooling Power Input		W	2153	1610
Heating Power Input		W	/	1880
Cooling Current Input		A	10	7.5
Heating Current Input		A	/	8.7
Rated Input		W	2500	2550
Rated Cooling Current		A	11	9.8
Rated Heating Current		A	/	11.5
Air Flow Volume		CFM	706/677/647/559/530/500/441	677/589/559/500/471/441/412
Dehumidifying Volume		Pint/h	4.23	5.28
EER2		(Btu/h)/W	10.45	13.65
COP2		(Btu/h)/W	/	12.45
SEER2		--	21	22
HSPF2		--	/	9.5
Application Area		yd <sup>2</sup>	32-50	23-34
Indoor Unit	Model		GWC24ATEXE-D6DNA1A/I GWC24ATEXE-D6DNA4A/I	GWH24ATEXF-D6DNA1G/I
	Product Code		CB574N14600 CB595N07300	CB574N18000
	Fan Type		Cross-flow	Cross-flow
	Fan Diameter Length(DXL)	mm	Φ111.5×830	Φ111.5×830
	Cooling Speed	r/min	1350/1200/1100/1000/950/900/850	1350/1200/1100/1000/950/900/850
	Heating Speed	r/min	/	1350/1200/1100/1000/950/900/850
	Fan Motor Power Output	W	50	50
	Fan Motor RLA	A	0.7	0.7
	Fan Motor Capacitor	μF	/	/
	Evaporator Form	--	Aluminum Fin-copper Tube	Aluminum Fin-copper Tube
	Evaporator Pipe Diameter	mm	Φ5	Φ7
	Evaporator Row-fin Gap	mm	2-1.4	2-1.4
	Evaporator Coil Length (LXDXW)	mm	840×25.4×381	840×25.4×381
	Swing Motor Model	--	MP35CP	MP35CP
	Swing Motor Power Output	W	2.5	2.5
	Fuse Current	A	3.15	3.15
	Sound Pressure Level	dB (A)	50/47/45/43/41/39/36	Cooling:50/47/44/41/39/37/36 Heating:52/48/44/41/39/37/36
	Sound Power Level	dB (A)	60/57/54/53/51/49/44	Cooling:60/57/54/51/49/47/46 Heating:62/58/54/51/49/47/46
	Dimension (WXHxD)	inch	42 28/64X13 7/64X9 44/64	42 7/16X13 7/64X9 11/16
	Dimension of Carton Box (LXWXH)	inch	44 26/64X15 63/64X12 46/64	44 13/32X15 63/64X12 23/32
Dimension of Package (LXWXH)	inch	44 39/64X16 19/64X13 7/64	44 39/64X16 19/64X13 7/64	
Net Weight	lb	32	33.1	
Gross Weight	lb	38.6	39.7	



Outdoor Unit	Outdoor Unit Model	--	GWC24ATEXE-D6DNA1A/O	GWH24ATEXF-D6DNA1G/O
	Outdoor Unit Product Code	--	CB574W14600	CB574W18000
	Compressor Manufacturer	--	ZHUHAI LANDA COMPRESSOR CO., LTD.	ZHUHAI LANDA COMPRESSOR CO., LTD.
	Compressor Model	--	FTz-SM151AXBD	FTz-SM151AXBD
	Compressor Oil	--	FW68DA	FW68DA or equivalent
	Compressor Type	--	Rotary	Rotary
	Compressor LRA.	A	/	35.00
	Compressor RLA	A	10.1	10
	Compressor Power Input	W	1330	1330
	Compressor Overload Protector	--	/	HPC 115/95U1 KSD115°C
	Throttling Method	--	Capillary	Electron expansion valve
	Set Temperature Range	°F	61~86	61~86
	Cooling Operation Ambient Temperature Range	°F	-4~122	-4~122
	Heating Operation Ambient Temperature Range	°F	/	-13~75
	Condenser Form	--	Aluminum Fin-copper Tube	Aluminum Fin-copper Tube
	Condenser Pipe Diameter	mm	Φ5	Φ7
	Condenser Rows-fin Gap	mm	2 - 1.4	2-1.4
	Condenser Coil Length (LXDXW)	mm	841.7×22.8×514.35	839×38.1×616
	Fan Motor Speed	rpm	900	850
	Fan Motor Power Output	W	40	60
	Fan Motor RLA	A	0.9	1.3
	Fan Motor Capacitor	μF	/	/
	Outdoor Unit Air Flow Volume	m <sup>3</sup> /h	2800	3200
	Fan Type	--	Axial-flow	Axial-flow
	Fan Diameter	mm	445	520
	Defrosting Method	--	/	Automatic Defrosting
	Climate Type	--	T1	T1
	Isolation	--	I	I
	Moisture Protection	--	IPX4	IPX4
	Permissible Excessive Operating Pressure for the Discharge Side	MPa	4.3	4.3
	Permissible Excessive Operating Pressure for the Suction Side	MPa	2.5	2.5
	Sound Pressure Level	dB (A)	56	58
	Sound Power Level	dB (A)	66	68
Dimension(WXHxD)	inch	34 3/8X21 27/32X14 51/64	37 23/32X25 63/64X15 53/64	
Dimension of Carton Box (LXWXH)	inch	37 21/64X16 27/32X23 17/64	40 33/64X17 53/64X28 5/32	
Dimension of Package(LXWXH)	inch	37 7/16X16 31/32X24 13/32	40 5/8X17 61/64X29 1/64	
Net Weight	lb	73.9	92.6	
Gross Weight	lb	80.5	102.5	
Refrigerant	--	R32	R32	
Refrigerant Charge	oz	30	42.3	
Connection Pipe	Connection Pipe Length	ft	24.6	24.6
	Connection Pipe Gas Additional Charge	oz/ft.	0.1	0.4
	Outer Diameter Liquid Pipe		1/4"	1/4"
	Outer Diameter Gas Pipe		5/8"	5/8"
	Max Distance Height	ft	32.8	82
	Max Distance Length	ft	82	131.2
Note: The connection pipe applies metric diameter.				

The above data is subject to change without notice. Please refer to the nameplate of the unit.

Model			GWC36ATEXH-D6DNA1G	LIV36HP230V1R32A
Product Code			CB574018200	CB574018100
Power Supply	Rated Voltage	V~	208/230	208/230
	Rated Frequency	Hz	60	60
	Phases		1	1
Power Supply Mode		--	Outdoor	Outdoor
Cooling Capacity		Btu/h	33600	33600
Heating Capacity		Btu/h	/	34000
Cooling Power Input		W	3169	3169
Heating Power Input		W	/	3267
Cooling Current Input		A	13.8	13.5
Heating Current Input		A	/	14.7
Rated Input		W	4000	4000
Rated Cooling Current		A	20	20
Rated Heating Current		A	/	20
Air Flow Volume		CFM	794/647/618/559/500/471/441	794/647/618/559/500/471/441
Dehumidifying Volume		Pint/h	7.40	7.40
EER2		(Btu/h)/W	10.6	10.6
COP2		(Btu/h)/W		10.4
SEER2		--	21	21
HSPF2		--		8.5
Application Area		yd <sup>2</sup>	55-83	55-83
Indoor Unit	Model		GWC36ATEXH-D6DNA1G/I	LIV36HP230V1R32AH
	Product Code		CB574N18200	CB574N18100
	Fan Type		Cross-flow	Cross-flow
	Fan Diameter Length(DXL)	mm	Φ111.5×830	Φ111.5×830
	Cooling Speed	r/min	1450/1150/1100/1000/950/900/850	1450/1150/1100/1000/950/900/850
	Heating Speed	r/min	/	1450/1200/1100/1050/1000/950/850
	Fan Motor Power Output	W	60	60
	Fan Motor RLA	A	0.7	0.7
	Fan Motor Capacitor	μF	/	/
	Evaporator Form	--	Aluminum Fin-copper Tube	Aluminum Fin-copper Tube
	Evaporator Pipe Diameter	mm	Φ7	Φ7
	Evaporator Row-fin Gap	mm	2-1.2	2-1.2
	Evaporator Coil Length (LXDXW)	mm	840×25.4×381	840×25.4×381
	Swing Motor Model	--	MP35CP	MP35CP
	Swing Motor Power Output	W	2.5	2.5
	Fuse Current	A	3.15	3.15
	Sound Pressure Level	dB (A)	52/45/44/41/40/38/36	Cooling:52/45/44/41/40/38/36 Heating:53/46/43/42/40/38/36
	Sound Power Level	dB (A)	62/55/54/51/50/48/46	Cooling:62/55/54/51/50/48/46 Heating:63/56/53/52/50/48/46
	Dimension (WXHXD)	inch	42 28/64X13 7/64X9 44/64	42 28/64X13 7/64X9 44/64
	Dimension of Carton Box (LXWXH)	inch	44 26/64X15 63/64X12 46/64	44 26/64X15 63/64X12 46/64
Dimension of Package (LXWXH)	inch	44 39/64X16 19/64X13 7/64	44 39/64X16 19/64X13 7/64	
Net Weight	lb	34.2	34.2	
Gross Weight	lb	40.8	40.8	

Outdoor Unit	Outdoor Unit Model	--	GWC36ATEXH-D6DNA1G/O	<b>LIV36HP230V1R32AO</b>
	Outdoor Unit Product Code	--	CB574W18200	CB574W18100
	Compressor Manufacturer	--	ZHUHAI LANDA COMPRESSOR CO., LTD.	ZHUHAI LANDA COMPRESSOR CO., LTD.
	Compressor Model	--	QXFS-D280zX070	QXFS-D280zX070
	Compressor Oil	--	FW68DA or equivalent	FW68DA or equivalent
	Compressor Type	--	Rotary	Rotary
	Compressor LRA.	A	40	40
	Compressor RLA	A	16	16
	Compressor Power Input	W	2294	2294
	Compressor Overload Protector	--	/	/
	Throttling Method	--	Electron expansion valve	Electron expansion valve
	Set Temperature Range	°F	61~86	61~86
	Cooling Operation Ambient Temperature Range	°F	-4~122	-4~122
	Heating Operation Ambient Temperature Range	°F	/	-13~75
	Condenser Form	--	Aluminum Fin-copper Tube	Aluminum Fin-copper Tube
	Condenser Pipe Diameter	mm	Φ7	Φ7
	Condenser Rows-fin Gap	mm	2 - 1.4	2 - 1.4
	Condenser Coil Length (LXDXW)	mm	955X38.1X704	955X38.1X704
	Fan Motor Speed	rpm	850	850
	Fan Motor Power Output	W	90	90
	Fan Motor RLA	A	1.7	1.7
	Fan Motor Capacitor	μF	/	/
	Outdoor Unit Air Flow Volume	m <sup>3</sup> /h	4500	4500
	Fan Type	--	Axial-flow	Axial-flow
	Fan Diameter	mm	570	570
	Defrosting Method	--	/	Automatic Defrosting
	Climate Type	--	T1	T1
	Isolation	--	I	I
	Moisture Protection	--	IPX4	IPX4
	Permissible Excessive Operating Pressure for the Discharge Side	MPa	4.3	4.3
	Permissible Excessive Operating Pressure for the Suction Side	MPa	2.5	2.5
	Sound Pressure Level	dB (A)	61	62
	Sound Power Level	dB (A)	71	72
	Dimension(WXHXD)	inch	39 3/8X29 3/8X16 13/16	39 3/8X29 3/8X16 13/16
Dimension of Carton Box (LXWXH)	inch	42 13/32X18 57/64X30 29/32	42 13/32X18 57/64X30 29/32	
Dimension of Package(LXWXH)	inch	42 33/64X19 1/64X31 57/64	42 33/64X19 1/64X31 57/64	
Net Weight	lb	120.2	122.4	
Gross Weight	lb	131.2	133.4	
Refrigerant	--	R32	R32	
Refrigerant Charge	oz	56.4	56.4	
Connection Pipe	Connection Pipe Length	ft	24.6	24.6
	Connection Pipe Gas Additional Charge	oz/ft.	0.1	0.4
	Outer Diameter Liquid Pipe		1/4"	1/4"
	Outer Diameter Gas Pipe		5/8"	5/8"
	Max Distance Height	ft	82	82
	Max Distance Length	ft	131.2	131.2
Note: The connection pipe applies metric diameter.				

Model			GWC09ATCXB-A6DNA1C	LIV09HP115V1R32A
Product Code			CB574016900	CB574016700
Power Supply	Rated Voltage	V~	115	115
	Rated Frequency	Hz	60	60
	Phases		1	1
Power Supply Mode		--	Outdoor	Outdoor
Cooling Capacity		Btu/h	9100	9100
Heating Capacity		Btu/h	/	10000
Cooling Power Input		W	762	762
Heating Power Input		W	/	803
Cooling Current Input		A	8.41	8.59
Heating Current Input		A	/	8.88
Rated Input		W	1150	1500
Rated Cooling Current		A	12	12.5
Rated Heating Current		A		15.4
Air Flow Volume		CFM	353/282/265/230/212/194/159	353/282/265/230/212/194/159
Dehumidifying Volume		Pint/h	1.69	1.69
EER2		(Btu/h)/W	11.9	11.9
COP2		(Btu/h)/W		12.4
SEER2		--	20.5	20.5
HSPF2		--		8.8
Application Area		yd <sup>2</sup>	12-18	12-18
Indoor Unit	Model		GWC09ATCXB-A6DNA1C/I	LIV09HP115V1R32AH
	Product Code		CB574N16900	CB574N16700
	Fan Type		Cross-flow	Cross-flow
	Fan Diameter Length(DXL)	mm	Φ94×630	Φ94×630
	Cooling Speed	r/min	1350/1150/1100/1000/950/850/750	1350/1150/1100/1000/950/850/750
	Heating Speed	r/min	/	1300/1100/1050/1000/950/850/800
	Fan Motor Power Output	W	20	20
	Fan Motor RLA	A	0.39	0.39
	Fan Motor Capacitor	μF	4	4
	Evaporator Form	--	Aluminum Fin-copper Tube	Aluminum Fin-copper Tube
	Evaporator Pipe Diameter	mm	Φ5	Φ5
	Evaporator Row-fin Gap	mm	2-1.3	2-1.3
	Evaporator Coil Length (LXDXW)	mm	634×22.8×266.7	634×22.8×266.7
	Swing Motor Model	--	MP24HF/MP24HF	MP24HF/MP24HF
	Swing Motor Power Output	W	1.5/1.5	1.5/1.5
	Fuse Current	A	3.15	3.15
	Sound Pressure Level	dB (A)	42/37/36/33/31/29/24	Cooling:43/38/37/34/32/31/24 Heating:40/35/34/32/30/28/25
	Sound Power Level	dB (A)	52/47/46/43/41/39/34	Cooling:53/48/47/44/42/41/34 Heating:50/45/44/42/40/38/35
	Dimension (WXHXD)	inch	32 7/8X10 53/64X7 7/8	32 7/8X10 53/64X7 7/8
	Dimension of Carton Box (LXWXH)	inch	35 3/64X12 61/64X10 15/64	35 3/64X12 61/64X10 15/64
Dimension of Package (LXWXH)	inch	35 15/64X13 37/64X10 43/64	35 15/64X13 37/64X10 43/64	
Net Weight	lb	19.8	19.8	
Gross Weight	lb	24.3	24.3	

Outdoor Unit	Outdoor Unit Model	--	GWC09ATCXB-A6DNA1C/O	<b>LIV09HP115V1R32AO</b>
	Outdoor Unit Product Code	--	CB574W16900	CB574W16700
	Compressor Manufacturer	--	ZHUHAI LANDA COMPRESSOR CO., LTD	ZHUHAI LANDA COMPRESSOR CO., LTD
	Compressor Model	--	QXF-N082zC170	QXF-N082zC170
	Compressor Oil	--	RB68GX or equivalent	RB68GX or equivalent
	Compressor Type	--	Rotary	Rotary
	Compressor LRA.	A	/	/
	Compressor RLA	A	13.7	13.7
	Compressor Power Input	W	630	630
	Compressor Overload Protector	--	/	/
	Throttling Method	--	Capillary	Capillary
	Set Temperature Range	°F	61~86	61~86
	Cooling Operation Ambient Temperature Range	°F	0~118	0~118
	Heating Operation Ambient Temperature Range	°F		-13~75
	Condenser Form	--	Aluminum Fin-copper Tube	Aluminum Fin-copper Tube
	Condenser Pipe Diameter	mm	Φ7	Φ7
	Condenser Rows-fin Gap	mm	1-1.2	1-1.2
	Condenser Coil Length (LXDXW)	mm	666×19.05×527	666×19.05×527
	Fan Motor Speed	rpm	850	850
	Fan Motor Power Output	W	30	30
	Fan Motor RLA	A	0.61	0.61
	Fan Motor Capacitor	μF	/	/
	Outdoor Unit Air Flow Volume	m <sup>3</sup> /h	1950	1950
	Fan Type	--	Axial-flow	Axial-flow
	Fan Diameter	mm	400	400
	Defrosting Method	--	/	Automatic
	Climate Type	--	T1	T1
	Isolation	--	I	I
	Moisture Protection	--	IPX4	IPX4
	Permissible Excessive Operating Pressure for the Discharge Side	MPa	4.3	4.3
	Permissible Excessive Operating Pressure for the Suction Side	MPa	2.5	2.5
	Sound Pressure Level	dB (A)	51	51
	Sound Power Level	dB (A)	61	61
Dimension(WXHXD)	inch	28 13/16X21 27/32X12 63/64	28 13/16X21 27/32X12 63/64	
Dimension of Carton Box (LXWXH)	inch	31 9/64X14 11/16X23 15/64	31 9/64X14 11/16X23 15/64	
Dimension of Package(LXWXH)	inch	31 17/64X14 51/64X24 7/32	31 17/64X14 51/64X24 7/32	
Net Weight	lb	52.9	55.1	
Gross Weight	lb	58.4	60.6	
Refrigerant	--	R32	R32	
Refrigerant Charge	oz	18.7	18.7	
Connection Pipe	Connection Pipe Length	ft	24.6	24.6
	Connection Pipe Gas Additional Charge	oz/ft.	0.1	0.2
	Outer Diameter Liquid Pipe		1/4"	1/4"
	Outer Diameter Gas Pipe		3/8"	3/8"
	Max Distance Height	ft	40	40
	Max Distance Length	ft	65	65
Note: The connection pipe applies metric diameter.				

The above data is subject to change without notice. Please refer to the nameplate of the unit.

Model			GWC09ATCXB-D6DNA1C	LIV09HP230V1R32A
Product Code			CB574016800	CB574016600
Power Supply	Rated Voltage	V~	208/230	208/230
	Rated Frequency	Hz	60	60
	Phases		1	1
Power Supply Mode		--	Outdoor	Outdoor
Cooling Capacity		Btu/h	9100	9100
Heating Capacity		Btu/h	/	10000
Cooling Power Input		W	729	729
Heating Power Input		W	/	771
Cooling Current Input		A	3.4	3.4
Heating Current Input		A	/	3.65
Rated Input		W	1050	1300
Rated Cooling Current		A	6.5	6.5
Rated Heating Current		A	/	7
Air Flow Volume		CFM	353/282/265/230/212/194/159	353/282/265/230/212/194/159
Dehumidifying Volume		Pint/h	1.69	1.69
EER2		(Btu/h)/W	12.5	12.5
COP2		(Btu/h)/W	/	13
SEER2		--	20.5	20.5
HSPF2		--	/	8.8
Application Area		yd <sup>2</sup>	12-18	12-18
Indoor Unit	Model		GWC09ATCXB-D6DNA1C/I	LIV09HP230V1R32AH
	Product Code		CB574N16800	CB574N16600
	Fan Type		Cross-flow	Cross-flow
	Fan Diameter Length(DXL)	mm	Φ94×630	Φ94×630
	Cooling Speed	r/min	1350/1150/1100/1000/950/850/750	1350/1150/1100/1000/950/850/750
	Heating Speed	r/min	/	1300/1100/1050/1000/950/850/800
	Fan Motor Power Output	W	20	20
	Fan Motor RLA	A	0.4	0.4
	Fan Motor Capacitor	μF	1.5	1.5
	Evaporator Form	--	Aluminum Fin-copper Tube	Aluminum Fin-copper Tube
	Evaporator Pipe Diameter	mm	Φ5	Φ5
	Evaporator Row-fin Gap	mm	2-1.3	2-1.3
	Evaporator Coil Length (LXDXW)	mm	634×22.8×266.7	634×22.8×266.7
	Swing Motor Model	--	MP24HF/MP24HF	MP24HF/MP24HF
	Swing Motor Power Output	W	1.5/1.5	1.5/1.5
	Fuse Current	A	3.15	3.15
	Sound Pressure Level	dB (A)	41/37/34/32/31/27/24	Cooling:41/37/34/32/31/27/24 Heating:41/36/34/32/31/28/26
	Sound Power Level	dB (A)	51/47/44/42/41/37/34	Cooling:51/47/44/42/41/37/34 Heating:51/46/44/42/41/38/36
	Dimension (WXHXD)	inch	32 7/8X10 53/64X7 7/8	32 7/8X10 53/64X7 7/8
	Dimension of Carton Box (LXWXH)	inch	35 3/64X12 61/64X10 15/64	35 3/64X12 61/64X10 15/64
Dimension of Package (LXWXH)	inch	35 15/64X13 37/64X10 43/64	35 15/64X13 37/64X10 43/64	
Net Weight	lb	19.8	19.8	
Gross Weight	lb	24.3	24.3	

Outdoor Unit	Outdoor Unit Model	--	GWC09ATCXB-D6DNA1C/O	<b>LIV09HP230V1R32AO</b>
	Outdoor Unit Product Code	--	CB574W16800	CB574W16600
	Compressor Manufacturer	--	ZHUHAI LANDA COMPRESSOR CO.,LTD	ZHUHAI LANDA COMPRESSOR CO.,LTD
	Compressor Model	--	QXF-N082zC170	QXF-N082zC170
	Compressor Oil	--	RB68GX or equivalent	RB68GX or equivalent
	Compressor Type	--	Rotary	Rotary
	Compressor LRA.	A	/	/
	Compressor RLA	A	6.5	6.5
	Compressor Power Input	W	630	630
	Compressor Overload Protector	--	/	/
	Throttling Method	--	Capillary	Capillary
	Set Temperature Range	°F	61~86	61~86
	Cooling Operation Ambient Temperature Range	°F	0~118	0~118
	Heating Operation Ambient Temperature Range	°F	/	-13~75
	Condenser Form	--	Aluminum Fin-copper Tube	Aluminum Fin-copper Tube
	Condenser Pipe Diameter	mm	Φ7	Φ7
	Condenser Rows-fin Gap	mm	1-1.2	1-1.2
	Condenser Coil Length (LXDXW)	mm	666×19.05×527	666×19.05×527
	Fan Motor Speed	rpm	850	850
	Fan Motor Power Output	W	30	30
	Fan Motor RLA	A	0.65	0.65
	Fan Motor Capacitor	μF	/	/
	Outdoor Unit Air Flow Volume	m <sup>3</sup> /h	1950	1950
	Fan Type	--	Axial-flow	Axial-flow
	Fan Diameter	mm	400	400
	Defrosting Method	--	/	Automatic
	Climate Type	--	T1	T1
	Isolation	--	I	I
	Moisture Protection	--	IPX4	IPX4
	Permissible Excessive Operating Pressure for the Discharge Side	MPa	4.3	4.3
	Permissible Excessive Operating Pressure for the Suction Side	MPa	2.5	2.5
	Sound Pressure Level	dB (A)	51	51
	Sound Power Level	dB (A)	61	61
Dimension(WXHxD)	inch	28 13/16X21 27/32X12 63/64	28 13/16X21 27/32X12 63/64	
Dimension of Carton Box (LXWXH)	inch	31 9/64X14 11/16X23 15/64	31 9/64X14 11/16X23 15/64	
Dimension of Package(LXWXH)	inch	31 17/64X14 51/64X24 7/32	31 17/64X14 51/64X24 7/32	
Net Weight	lb	50.7	52.9	
Gross Weight	lb	56.2	58.4	
Refrigerant	--	R32	R32	
Refrigerant Charge	oz	18.7	18.7	
Connection Pipe	Connection Pipe Length	ft	24.6	24.6
	Connection Pipe Gas Additional Charge	oz/ft.	0.1	0.2
	Outer Diameter Liquid Pipe		1/4"	1/4"
	Outer Diameter Gas Pipe		3/8"	3/8"
	Max Distance Height	ft	39.4	39.4
	Max Distance Length	ft	65.6	65.6
Note: The connection pipe applies metric diameter.				

The above data is subject to change without notice. Please refer to the nameplate of the unit.

Model			GWC12ATCXB-A6DNA1A	LIV12HP115V1R32A
Product Code			CB574016500	CB574018500
Power Supply	Rated Voltage	V~	115	115
	Rated Frequency	Hz	60	60
	Phases		1	1
Power Supply Mode		--	Outdoor	Outdoor
Cooling Capacity		Btu/h	12000	12000
Heating Capacity		Btu/h	/	12000
Cooling Power Input		W	1231	1231
Heating Power Input		W	/	1004
Cooling Current Input		A	13.07	13.72
Heating Current Input		A	/	10.78
Rated Input		W	1550	1650
Rated Cooling Current		A	14.34	14.34
Rated Heating Current		A	/	14.64
Air Flow Volume		CFM	424/353/324/277/247/224/182/165	424/353/324/277/247/224/182/165
Dehumidifying Volume		Pint/h	2.96	2.96
EER2		(Btu/h)/W	9.75	9.75
COP2		(Btu/h)/W	/	11.95
SEER2		--	19	19
HSPF2		--	/	8.5
Application Area		yd <sup>2</sup>	19-28	19-28
Indoor Unit	Model		GWC12ATCXB-A6DNA1A/I	LIV12HP115V1R32AH
	Product Code		CB574N16500	CB574N18500
	Fan Type		Cross-flow	Cross-flow
	Fan Diameter Length(DXL)	mm	Φ94×630	Φ94×630
	Cooling Speed	r/min	1550/1200/1120/1050/980/920/750/500	1550/1200/1120/1050/980/920/750/500
	Heating Speed	r/min	/	1450/1200/1140/1080/1020/960/900
	Fan Motor Power Output	W	35	35
	Fan Motor RLA	A	0.7	0.7
	Fan Motor Capacitor	μF	/	/
	Evaporator Form	--	Aluminum Fin-copper Tube	Aluminum Fin-copper Tube
	Evaporator Pipe Diameter	mm	Φ5	Φ5
	Evaporator Row-fin Gap	mm	2-1.3	2-1.3
	Evaporator Coil Length (LXDXW)	mm	634×22.8×266.7	634×22.8×266.7
	Swing Motor Model	--	MP24HF/MP24HF	MP24HF/MP24HF
	Swing Motor Power Output	W	1.5/1.5	1.5/1.5
	Fuse Current	A	3.15	3.15
	Sound Pressure Level	dB (A)	47/39/38/35/33/32/27/22	Cooling:47/39/38/35/33/32/27/22 Heating:44/39/37/36/34/32/30
	Sound Power Level	dB (A)	57/49/48/45/43/42/37/32	Cooling:57/49/48/45/43/42/37/32 Heating:54/49/47/46/44/42/40
	Dimension (WXHXD)	inch	32 7/8X10 53/64X7 7/8	32 7/8X10 53/64X7 7/8
	Dimension of Carton Box (LXWXH)	inch	35 3/64X12 61/64X10 15/64	35 3/64X12 61/64X10 15/64
Dimension of Package (LXWXH)	inch	35 15/64X13 37/64X10 43/64	35 15/64X13 37/64X10 43/64	
Net Weight	lb	19.8	19.8	
Gross Weight	lb	24.3	24.3	



Outdoor Unit	Outdoor Unit Model	--	GWC12ATCXB-A6DNA1A/O	<b>LIV12HP115V1R32AO</b>
	Outdoor Unit Product Code	--	CB574W16500	CB574W18500
	Compressor Manufacturer	--	ZHUHAI LANDA COMPRESSOR CO.,LTD	ZHUHAI LANDA COMPRESSOR CO.,LTD
	Compressor Model	--	FTz-AN108ACBD	FTz-AN108ACBD
	Compressor Oil	--	FW68DA or equivalent	FW68DA or equivalent
	Compressor Type	--	Rotary	Rotary
	Compressor LRA.	A		
	Compressor RLA	A	14	14
	Compressor Power Input	W	857	857
	Compressor Overload Protector	--	/	/
	Throttling Method	--	Capillary	Capillary
	Set Temperature Range	°F	61~86	61~86
	Cooling Operation Ambient Temperature Range	°F	0~118	0~118
	Heating Operation Ambient Temperature Range	°F		-13~75
	Condenser Form	--	Aluminum Fin-copper Tube	Aluminum Fin-copper Tube
	Condenser Pipe Diameter	mm	Φ7	Φ7
	Condenser Rows-fin Gap	mm	1-1.2	1-1.2
	Condenser Coil Length (LXDXW)	mm	677×19.05×528	677×19.05×528
	Fan Motor Speed	rpm	810	810
	Fan Motor Power Output	W	30	30
	Fan Motor RLA	A	0.8	0.8
	Fan Motor Capacitor	μF	/	/
	Outdoor Unit Air Flow Volume	m <sup>3</sup> /h	1950	1950
	Fan Type	--	Axial-flow	Axial-flow
	Fan Diameter	mm	400	400
	Defrosting Method	--	/	Automatic Defrosting
	Climate Type	--	T1	T1
	Isolation	--	I	I
	Moisture Protection	--	IPX4	IPX4
	Permissible Excessive Operating Pressure for the Discharge Side	MPa	4.3	4.3
	Permissible Excessive Operating Pressure for the Suction Side	MPa	2.5	2.5
	Sound Pressure Level	dB (A)	52	52
	Sound Power Level	dB (A)	62	62
	Dimension(WXHXD)	inch	28 13/16X21 27/32X12 63/64	28 13/16X21 27/32X12 63/64
Dimension of Carton Box (LXWXH)	inch	31 9/64X14 11/16X23 15/64	31 9/64X14 11/16X23 15/64	
Dimension of Package(LXWXH)	inch	31 17/64X14 51/64X24 7/32	31 17/64X14 51/64X24 7/32	
Net Weight	lb	56.2	58.4	
Gross Weight	lb	61.7	63.9	
Refrigerant	--	R32	R32	
Refrigerant Charge	oz	17.6	17.6	
Connection Pipe	Connection Pipe Length	ft	24.6	24.6
	Connection Pipe Gas Additional Charge	oz/ft.	0.1	0.2
	Outer Diameter Liquid Pipe		1/4"	1/4"
	Outer Diameter Gas Pipe		3/8"	3/8"
	Max Distance Height	ft	40	40
	Max Distance Length	ft	65.6	65.6
Note: The connection pipe applies metric diameter.				

The above data is subject to change without notice. Please refer to the nameplate of the unit.

Model			GWC12ATCXB-D6DNA1A	LIV12HP230V1R32A
Product Code			CB574016200	CB574018400
Power Supply	Rated Voltage	V~	208/230	208/230
	Rated Frequency	Hz	60	60
	Phases		1	1
Power Supply Mode		--	Outdoor	Outdoor
Cooling Capacity		Btu/h	12000	12000
Heating Capacity		Btu/h	/	12000
Cooling Power Input		W	1231	1231
Heating Power Input		W	/	1004
Cooling Current Input		A	5.31	5.58
Heating Current Input		A	/	4.55
Rated Input		W	1550	1650
Rated Cooling Current		A	7.02	7.02
Rated Heating Current		A	/	7.47
Air Flow Volume		CFM	424/353/324/277/247/224/182/165	424/353/324/277/247/224/182/165
Dehumidifying Volume		Pint/h	2.96	2.96
EER2		(Btu/h)/W	9.75	9.75
COP2		(Btu/h)/W	/	11.95
SEER2		--	19	19
HSPF2		--	/	8.5
Application Area		yd <sup>2</sup>	19-28	19-28
Indoor Unit	Model		GWC12ATCXB-D6DNA1A/I	LIV12HP230V1R32AH
	Product Code		CB574N16200	CB574N18400
	Fan Type		Cross-flow	Cross-flow
	Fan Diameter Length(DXL)	mm	Φ94×630	Φ94×630
	Cooling Speed	r/min	1550/1200/1120/1050/980/920/750/500	1550/1200/1120/1050/980/920/750/500
	Heating Speed	r/min	/	1450/1200/1140/1080/1020/960/900
	Fan Motor Power Output	W	55	55
	Fan Motor RLA	A	0.7	0.7
	Fan Motor Capacitor	μF	/	/
	Evaporator Form	--	Aluminum Fin-copper Tube	Aluminum Fin-copper Tube
	Evaporator Pipe Diameter	mm	Φ5	Φ5
	Evaporator Row-fin Gap	mm	2-1.3	2-1.3
	Evaporator Coil Length (LXDXW)	mm	634×22.8×266.7	634×22.8×266.7
	Swing Motor Model	--	MP24HF/MP24HF	MP24HF/MP24HF
	Swing Motor Power Output	W	1.5/1.5	1.5/1.5
	Fuse Current	A	3.15	3.15
	Sound Pressure Level	dB (A)	47/39/38/35/33/32/27/22	Cooling:47/39/38/35/33/32/27/22 Heating:44/39/37/36/34/32/30
	Sound Power Level	dB (A)	57/49/48/45/43/42/37/32	Cooling:57/49/48/45/43/42/37/32 Heating:54/49/47/46/44/42/40
	Dimension (WXHXD)	inch	32 7/8X10 53/64X7 7/8	32 7/8X10 53/64X7 7/8
	Dimension of Carton Box (LXWXH)	inch	35 3/64X12 61/64X10 15/64	35 3/64X12 61/64X10 15/64
Dimension of Package (LXWXH)	inch	35 15/64X13 37/64X10 43/64	35 15/64X13 37/64X10 43/64	
Net Weight	lb	19.8	19.8	
Gross Weight	lb	24.3	24.3	

Outdoor Unit	Outdoor Unit Model	--	GWC12ATCXB-D6DNA1A/O	<b>LIV12HP230V1R32AO</b>
	Outdoor Unit Product Code	--	CB574W16200	CB574W18400
	Compressor Manufacturer	--	ZHUHAI LANDA COMPRESSOR CO.,LTD	ZHUHAI LANDA COMPRESSOR CO.,LTD
	Compressor Model	--	FTz-AN108ACBD	FTz-AN108ACBD
	Compressor Oil	--	FW68DA or equivalent	FW68DA or equivalent
	Compressor Type	--	Rotary	Rotary
	Compressor LRA.	A	/	/
	Compressor RLA	A	8	8
	Compressor Power Input	W	857	857
	Compressor Overload Protector	--	/	/
	Throttling Method	--	Capillary	Capillary
	Set Temperature Range	°F	61~86	61~86
	Cooling Operation Ambient Temperature Range	°F	0~118	0~118
	Heating Operation Ambient Temperature Range	°F	/	-13~75
	Condenser Form	--	Aluminum Fin-copper Tube	Aluminum Fin-copper Tube
	Condenser Pipe Diameter	mm	Φ7	Φ7
	Condenser Rows-fin Gap	mm	1-1.2	1-1.2
	Condenser Coil Length (LXDXW)	mm	677×19.05×528	677×19.05×528
	Fan Motor Speed	rpm	810	900
	Fan Motor Power Output	W	30	30
	Fan Motor RLA	A	0.8	0.8
	Fan Motor Capacitor	μF	/	/
	Outdoor Unit Air Flow Volume	m <sup>3</sup> /h	1950	1950
	Fan Type	--	Axial-flow	Axial-flow
	Fan Diameter	mm	400	400
	Defrosting Method	--	/	Automatic Defrosting
	Climate Type	--	T1	T1
	Isolation	--	I	I
	Moisture Protection	--	IPX4	IPX4
	Permissible Excessive Operating Pressure for the Discharge Side	MPa	4.3	4.3
	Permissible Excessive Operating Pressure for the Suction Side	MPa	2.5	2.5
	Sound Pressure Level	dB (A)	52	52
	Sound Power Level	dB (A)	62	62
	Dimension(WXHxD)	inch	28 13/16X21 27/32X12 63/64	28 13/16X21 27/32X12 63/64
Dimension of Carton Box (LXWXH)	inch	31 9/64X14 11/16X23 15/64	31 9/64X14 11/16X23 15/64	
Dimension of Package(LXWXH)	inch	31 17/64X14 51/64X24 7/32	31 17/64X14 51/64X24 7/32	
Net Weight	lb	54	56.2	
Gross Weight	lb	59.5	61.7	
Refrigerant	--	R32	R32	
Refrigerant Charge	oz	17.6	17.6	
Connection Pipe	Connection Pipe Length	ft	24.6	24.6
	Connection Pipe Gas Additional Charge	oz/ft.	0.1	0.2
	Outer Diameter Liquid Pipe		1/4"	1/4"
	Outer Diameter Gas Pipe		3/8"	3/8"
	Max Distance Height	ft	40	40
	Max Distance Length	ft	65.6	65.6
Note: The connection pipe applies metric diameter.				

The above data is subject to change without notice. Please refer to the nameplate of the unit.

Model			GWC18ATDXD-D6DNA1A	LIV18HP230V1R32A
Product Code			CB574017600	CB574017700
Power Supply	Rated Voltage	V~	208/230	208/230
	Rated Frequency	Hz	60	60
	Phases		1	1
Power Supply Mode		--	Outdoor	Outdoor
Cooling Capacity		Btu/h	18000	18000
Heating Capacity		Btu/h	/	19100
Cooling Power Input		W	1500	1500
Heating Power Input		W	/	1435
Cooling Current Input		A	6.65	6.65
Heating Current Input		A	/	6.4
Rated Input		W	2300	2300
Rated Cooling Current		A	9.5	9.5
Rated Heating Current		A	/	9.5
Air Flow Volume		CFM	618/512/471/435/394/335/282/0	618/512/471/435/394/335/282/0
Dehumidifying Volume		Pint/h	3.80	3.80
EER2		(Btu/h)/W	12.35	12.35
COP2		(Btu/h)/W	/	13.31
SEER2		--	20	20
HSPF2		--	/	8.5
Application Area		yd <sup>2</sup>	23-34	23-34
Indoor Unit	Model		GWC18ATDXD-D6DNA1A/I	LIV18HP230V1R32AH
	Product Code		CB574N17600	CB574N17700
	Fan Type		Cross-flow	Cross-flow
	Fan Diameter Length(DXL)	mm	Φ108x691	Φ108x691
	Cooling Speed	r/min	1350/1200/1120/1050/980/860/750	1350/1200/1120/1050/980/860/750
	Heating Speed	r/min	/	1350/1200/1120/1050/950/850/750
	Fan Motor Power Output	W	50	50
	Fan Motor RLA	A	0.7	0.7
	Fan Motor Capacitor	μF	/	/
	Evaporator Form	--	Aluminum Fin-copper Tube	Aluminum Fin-copper Tube
	Evaporator Pipe Diameter	mm	Φ5	Φ5
	Evaporator Row-fin Gap	mm	2-1.2	2-1.2
	Evaporator Coil Length (LXDXW)	mm	700×22.8×381	700×22.8×381
	Swing Motor Model	--	MP35CJ/MP24HF	MP35CJ/MP24HF
	Swing Motor Power Output	W	2.5/1.5	2.5/1.5
	Fuse Current	A	3.15	3.15
	Sound Pressure Level	dB (A)	53/49/46/44/42/38/34	Cooling:53/49/46/44/42/38/34 Heating:49/46/44/41/38/35/30
	Sound Power Level	dB (A)	63/59/56/54/52/48/44	Cooling:63/59/56/54/52/48/44 Heating:59/56/54/51/48/45/40
	Dimension (WXHXD)	inch	37 1/8X13 7/64X9 11/16	37 1/8X13 7/64X9 11/16
	Dimension of Carton Box (LXWXH)	inch	39 7/32X15 5/8X12 9/32	39 7/32X15 5/8X12 9/32
Dimension of Package (LXWXH)	inch	39 13/32X15 15/16X12 43/64	39 13/32X15 15/16X12 43/64	
Net Weight	lb	28.7	28.7	
Gross Weight	lb	34.2	34.2	

Outdoor Unit	Outdoor Unit Model	--	GWC18ATDXD-D6DNA1A/O	<b>LIV18HP230V1R32AO</b>
	Outdoor Unit Product Code	--	CB574W17600	CB574W17700
	Compressor Manufacturer	--	ZHUHAI LANDA COMPRESSOR CO. LTD.	ZHUHAI LANDA COMPRESSOR CO. LTD.
	Compressor Model	--	QXF-A120zF170	QXF-A120zF170
	Compressor Oil	--	ZE-GLES RB68GX	ZE-GLES RB68GX
	Compressor Type	--	Rotary	Rotary
	Compressor LRA.	A	20	20
	Compressor RLA	A	8.5	8.5
	Compressor Power Input	W	953	953
	Compressor Overload Protector	--	/	/
	Throttling Method	--	Capillary	Capillary
	Set Temperature Range	°F	61~86	61~86
	Cooling Operation Ambient Temperature Range	°F	0~118	0~118
	Heating Operation Ambient Temperature Range	°F	/	-13~75
	Condenser Form	--	Aluminum Fin-copper Tube	Aluminum Fin-copper Tube
	Condenser Pipe Diameter	mm	Φ7	Φ7.94
	Condenser Rows-fin Gap	mm	2-1.4	2-1.4
	Condenser Coil Length (LXDXW)	mm	787×23×514	761.5×38.1×528
	Fan Motor Speed	rpm	940	940
	Fan Motor Power Output	W	30	30
	Fan Motor RLA	A	0.8	0.8
	Fan Motor Capacitor	μF	/	/
	Outdoor Unit Air Flow Volume	m <sup>3</sup> /h	2520	2520
	Fan Type	--	Axial-flow	Axial-flow
	Fan Diameter	mm	420	420
	Defrosting Method	--	/	Automatic
	Climate Type	--	T1	T1
	Isolation	--	I	I
	Moisture Protection	--	IPX4	IPX4
	Permissible Excessive Operating Pressure for the Discharge Side	MPa	4.3	4.3
	Permissible Excessive Operating Pressure for the Suction Side	MPa	2.5	2.5
	Sound Pressure Level	dB (A)	57	57
	Sound Power Level	dB (A)	67	67
Dimension(WXHXD)	inch	31 37/64X21 27/32X13 25/32	31 37/64X21 27/32X13 25/32	
Dimension of Carton Box (LXWXH)	inch	34 7/32X15 35/64X23 25/64	34 7/32X15 35/64X23 25/64	
Dimension of Package(LXWXH)	inch	34 21/64X15 43/64X24 13/32	34 21/64X15 43/64X24 13/32	
Net Weight	lb	66.2	70.6	
Gross Weight	lb	71.7	76.1	
Refrigerant	--	R32	R32	
Refrigerant Charge	oz	30.7	32.5	
Connection Pipe	Connection Pipe Length	ft	24.6	24.6
	Connection Pipe Gas Additional Charge	oz/ft.	0.1	0.2
	Outer Diameter Liquid Pipe		1/4"	1/4"
	Outer Diameter Gas Pipe		1/2"	1/2"
	Max Distance Height	ft	82	82
	Max Distance Length	ft	131.2	131.2
Note: The connection pipe applies metric diameter.				

The above data is subject to change without notice. Please refer to the nameplate of the unit.

Model			GWC24ATEXF-D6DNA1F	LIV24HP230V1R32A
Product Code			CB574017900	CB574017800
Power Supply	Rated Voltage	V~	208/230	208/230
	Rated Frequency	Hz	60	60
	Phases		1	1
Power Supply Mode		--	Outdoor	Outdoor
Cooling Capacity		Btu/h	24000	24000
Heating Capacity		Btu/h	/	24000
Cooling Power Input		W	2130	2010
Heating Power Input		W	/	1950
Cooling Current Input		A		9
Heating Current Input		A	/	9
Rated Input		W	2500	2600
Rated Cooling Current		A	12	11
Rated Heating Current		A	/	12
Air Flow Volume		CFM	677/589/559/500/471/441/412	677/589/559/500/471/441/412
Dehumidifying Volume		Pint/h	5.28	5.28
EER2		(Btu/h)/W	11.6	11.9
COP2		(Btu/h)/W	/	12.3
SEER2		--	19	19
HSPF2		--	/	8.5
Application Area		yd <sup>2</sup>	23-34	23-34
Indoor Unit	Model		GWC24ATEXF-D6DNA1F/I	LIV24HP230V1R32AH
	Product Code		CB574N17900	CB574N17800
	Fan Type		Cross-flow	Cross-flow
	Fan Diameter Length(DXL)	mm	Φ111.5×830	Φ111.5×830
	Cooling Speed	r/min	1350/1200/1100/1000/950/900/850	1350/1200/1100/1000/950/900/850
	Heating Speed	r/min	/	1350/1200/1100/1000/950/900/850
	Fan Motor Power Output	W	50	50
	Fan Motor RLA	A	0.6	0.6
	Fan Motor Capacitor	μF	/	/
	Evaporator Form	--	Aluminum Fin-copper Tube	Aluminum Fin-copper Tube
	Evaporator Pipe Diameter	mm	Φ7	Φ7
	Evaporator Row-fin Gap	mm	2-1.4	2-1.4
	Evaporator Coil Length (LXDXW)	mm	840×25.4×381	840×25.4×381
	Swing Motor Model	--	MP35CP/MP24HF	MP35CP/MP24HF
	Swing Motor Power Output	W	2.5/1.5	2.5/1.5
	Fuse Current	A	3.15	3.15
	Sound Pressure Level	dB (A)	51/47/44/41/40/38/36	Cooling:51/47/44/41/40/38/36 Heating:51/47/44/41/39/38/36
	Sound Power Level	dB (A)	61/57/54/51/50/48/36	Cooling:61/57/54/51/50/48/36 Heating:61/57/54/51/49/48/46
	Dimension (WXHXD)	inch	42 28/64X13 7/64X9 44/64	42 7/16X13 7/64X9 11/16
	Dimension of Carton Box (LXWXH)	inch	44 26/64X15 63/64X12 46/64	44 13/32X15 63/64X12 23/32
Dimension of Package (LXWXH)	inch	44 39/64X16 19/64X13 7/64	44 39/64X16 19/64X13 7/64	
Net Weight	lb	33.1	33.1	
Gross Weight	lb	39.7	39.7	

Outdoor Unit	Outdoor Unit Model	--	GWC24ATEXF-D6DNA1F/O	<b>LIV24HP230V1R32AO</b>
	Outdoor Unit Product Code	--	CB574W17900	CB574W17900
	Compressor Manufacturer	--	ZHUHAI LANDA COMPRESSOR CO. LTD.	ZHUHAI LANDA COMPRESSOR CO. LTD.
	Compressor Model	--	FTz-SM151AXB	FTz-SM151AXB
	Compressor Oil	--	FW68DA or equivalent	FW68DA or equivalent
	Compressor Type	--	Rotary	Rotary
	Compressor LRA	A	35	35
	Compressor RLA	A	10	10
	Compressor Power Input	W	1330	1330
	Compressor Overload Protector	--	HPC 115/95U1 KSD115°C	HPC 115/95U1 KSD115°C
	Throttling Method	--	Capillary	Capillary
	Set Temperature Range	°F	61~86	61~86
	Cooling Operation Ambient Temperature Range	°F	0~118	0~118
	Heating Operation Ambient Temperature Range	°F		-13~75
	Condenser Form	--	Aluminum Fin-copper Tube	Aluminum Fin-copper Tube
	Condenser Pipe Diameter	mm	Φ5	Φ7
	Condenser Rows-fin Gap	mm	1.3	2-1.4
	Condenser Coil Length (LXDXW)	mm	855×22.8×609.6	839×38.1×616
	Fan Motor Speed	rpm	850	800
	Fan Motor Power Output	W	60	50
	Fan Motor RLA	A	0.8	1
	Fan Motor Capacitor	μF		3.5
	Outdoor Unit Air Flow Volume	m <sup>3</sup> /h	3200	3200
	Fan Type	--	Axial-flow	Axial-flow
	Fan Diameter	mm	520	520
	Defrosting Method	--	/	/
	Climate Type	--	T1	T1
	Isolation	--	1	1
	Moisture Protection	--	IPX4	IPX4
	Permissible Excessive Operating Pressure for the Discharge Side	MPa	4.3	4.3
	Permissible Excessive Operating Pressure for the Suction Side	MPa	2.5	2.5
	Sound Pressure Level	dB (A)	59	58
	Sound Power Level	dB (A)	69	68
Dimension(WXHXD)	inch	37 23/32X25 63/64X15 53/64	37 23/32X25 63/64X15 53/64	
Dimension of Carton Box (LXWXH)	inch	40 33/64X17 53/64X28 5/32	40 33/64X17 53/64X28 5/32	
Dimension of Package(LXWXH)	inch	40 5/8X17 61/64X29 1/64	40 5/8X17 61/64X29 1/64	
Net Weight	lb	86	93.7	
Gross Weight	lb	95.9	103.6	
Refrigerant	--	R32	R32	
Refrigerant Charge	oz	35.3	42.3	
Connection Pipe	Connection Pipe Length	ft	24.6	24.6
	Connection Pipe Gas Additional Charge	oz/ft.	0.1	0.1
	Outer Diameter Liquid Pipe		1/4"	1/4"
	Outer Diameter Gas Pipe		1/2"	1/2"
	Max Distance Height	ft	82	82
	Max Distance Length	ft	131.2	131.2
Note: The connection pipe applies metric diameter.				

The above data is subject to change without notice. Please refer to the nameplate of the unit.

# 2. Specifications

## 2.2 Capacity Variation Ratio According to Temperature

For cooling temperature range of 0~118°F models

Cooling:

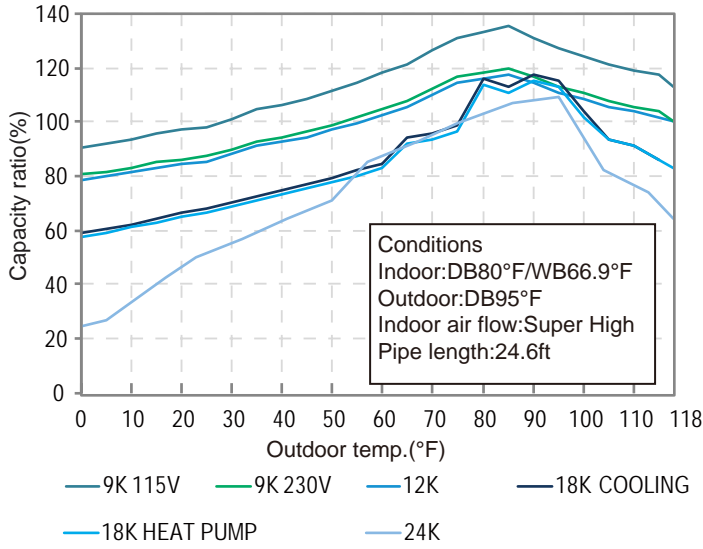

Heating:

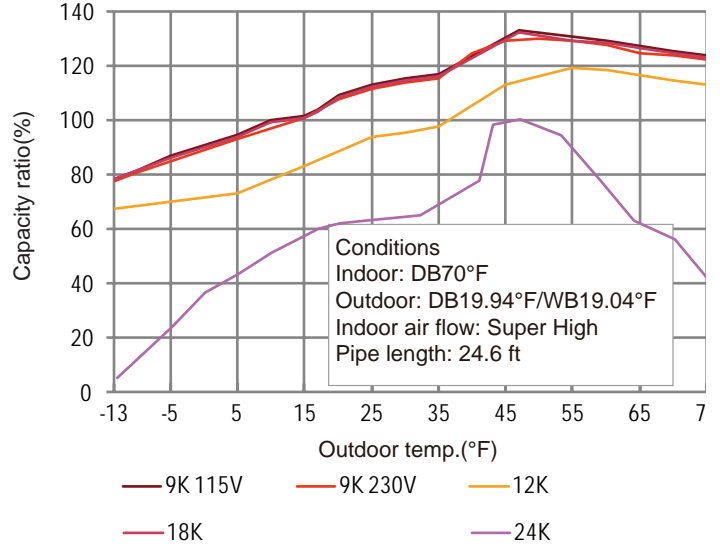

For cooling temperature range of -4~122°F models

Cooling:

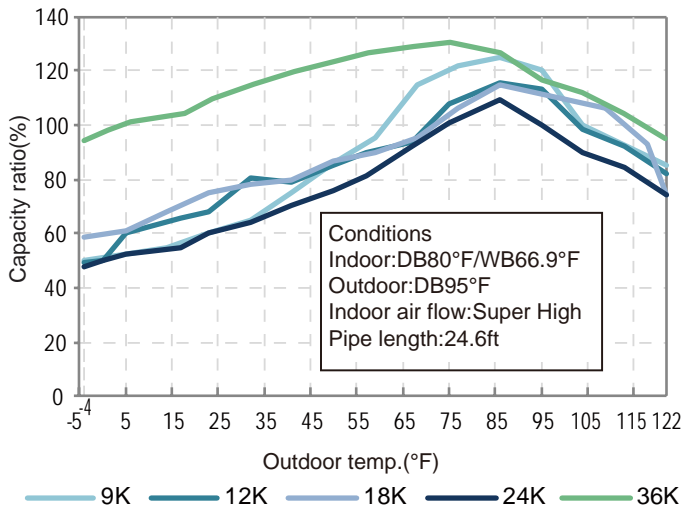

Heating:

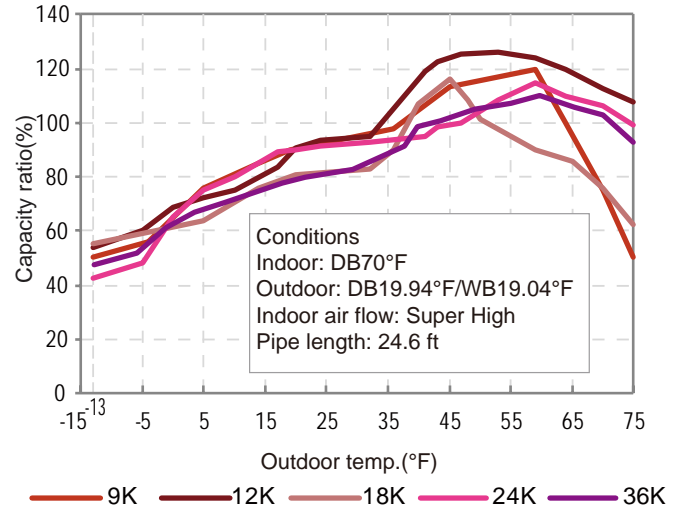

## 2.3 Cooling and Heating Data Sheet in Rated Frequency

Cooling:

Rated cooling condition(°F) (DB/WB)		Model	Pressure of gas pipe connecting indoor and outdoor unit	Inlet and outlet pipe temperature of heat exchanger		Fan speed of indoor unit	Fan speed of outdoor unit
Indoor	Outdoor			P (MPa)	T1 (°F)		
80/66.9	95/-	09K	0.8~1.0	in:46.4~51.8 out:51.8~57.2	in:167~181.4 out:98.6~118.4	Super High	High
80/66.9	95/-	12K	0.8~1.0	in:46.4~51.8 out:51.8~57.2	in:167~181.4 out:98.6~118.4	Super High	High
80/66.9	95/-	18K	0.8~1.0	in:46.4~51.8 out:51.8~57.2	in:167~181.4 out:98.6~118.4	Super High	High
80/66.9	95/-	24K	0.8~1.0	in:46.4~51.8 out:51.8~57.2	in:167~181.4 out:98.6~118.4	Super High	High
80/66.9	95/-	36K	0.8~1.1	46.8 to 52.8	127 to 96.8	Super High	High



Heating:

Rated heating condition(°F) (DB/WB)		Model	Pressure of gas pipe connecting indoor and outdoor unit	Inlet and outlet pipe temperature of heat exchanger		Fan speed of indoor unit	Fan speed of outdoor unit
Indoor	Outdoor			P (PSIG)	T1 (°F)		
70/60	19.94/19.04	09K	2.4~2.8	in:167~181.4 out:98.6~113	in:33.8~37.4 out:35.6~42.8	Super High	High
70/60	19.94/19.04	12K	2.4~2.8	in:167~181.4 out:98.6~113	in:33.8~37.4 out:35.6~42.8	Super High	High
70/60	19.94/19.04	18K	3.4~3.8	in:167~181.4 out:98.6~113	in:33.8~37.4 out:35.6~42.8	Super High	High
70/60	19.94/19.04	24K	3.4~3.8	in:167~181.4 out:98.6~113	in:33.8~37.4 out:35.6~42.8	Super High	High
70/-	19.94/19.04	36K	2.5~2.7	134.4 to 102	36 to 39	Super High	High

**Instruction:**

T1: Inlet and outlet pipe temperature of evaporator

T2: Inlet and outlet pipe temperature of condenser

P: Pressure at the side of big valve

Connection pipe length: 24.6ft.

# 3. Outline Dimension Diagram

## 3.1 Indoor Unit

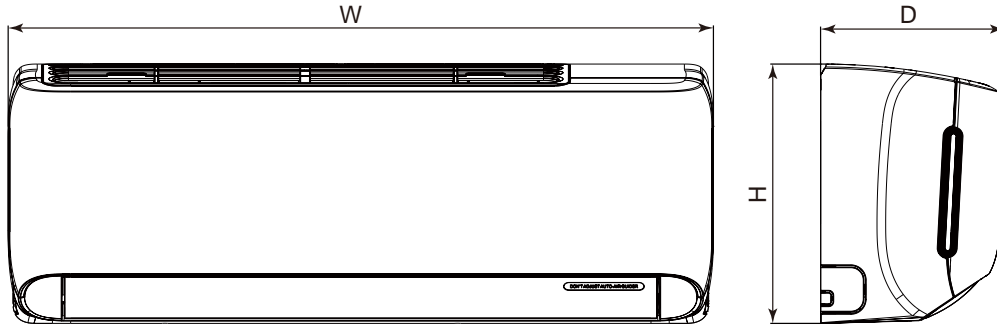

LIV09HP115V1R32AH  
LIV12HP115V1R32AH  
LIV09HP230V1R32AH  
LIV12HP230V1R32AH

ATC

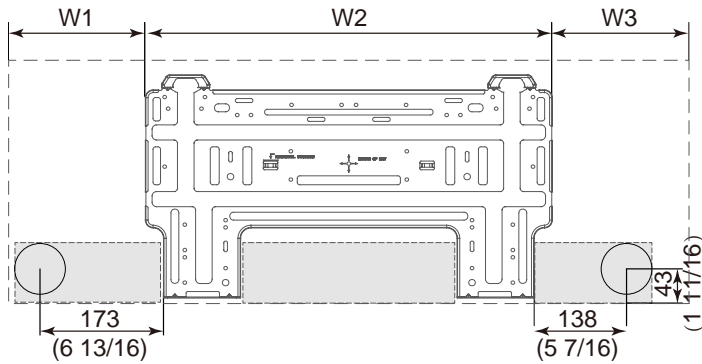
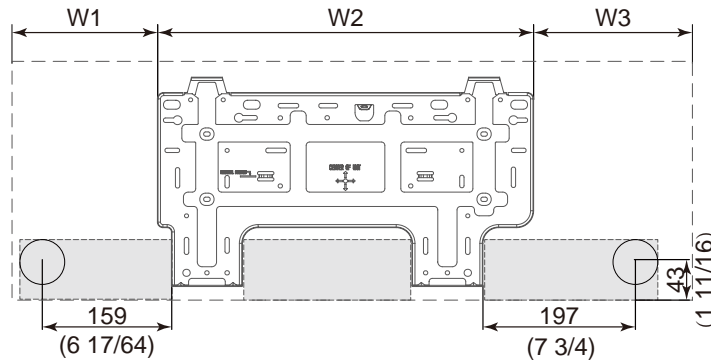

LIV18HP230V1R32AH

ATD

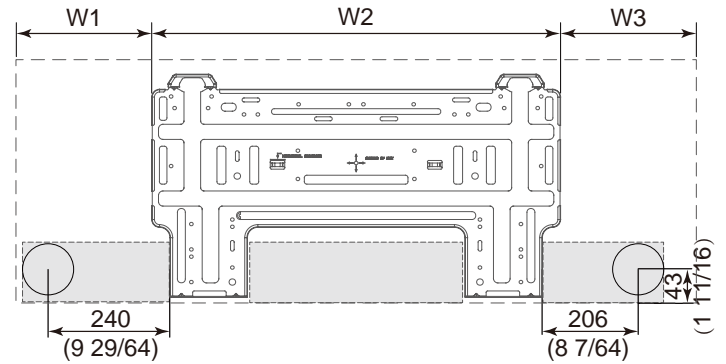

LIV30HP230V1R32AH, LIV36HP230V1R32AH

ATE

Unit:inch

Model	W	H	D	W1	W2	W3
ATA	27 7/8	10 15/64	7 9/32	3 25/32	18 5/32	5 15/16
ATB	30 53/64	10 15/64	7 9/32	5 9/32	18 5/32	7 13/32
ATC	32 7/8	10 53/64	7 7/8	7 1/64	18 3/16	7 43/64
ATD	37 1/8	13 7/64	9 11/16	7 35/64	22 7/64	7 31/64
ATE	42 7/16	13 7/64	9 11/16	6 15/64	22 7/64	10 5/32

### 3.2 Outdoor Unit

LIV09HP115V1R32AO  
LIV12HP115V1R32AO

LIV09HP230V1R32AO  
LIV12HP230V1R32AO

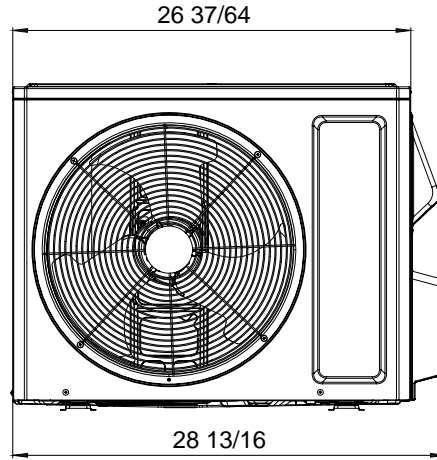
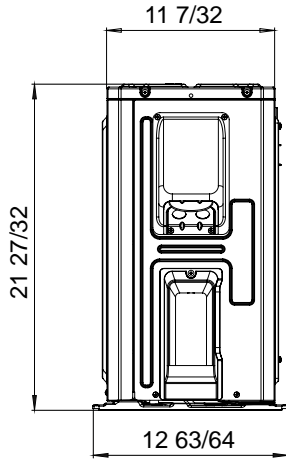

Unit:inch

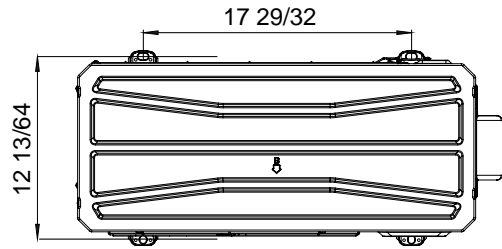

LIV18HP230V1R32AO

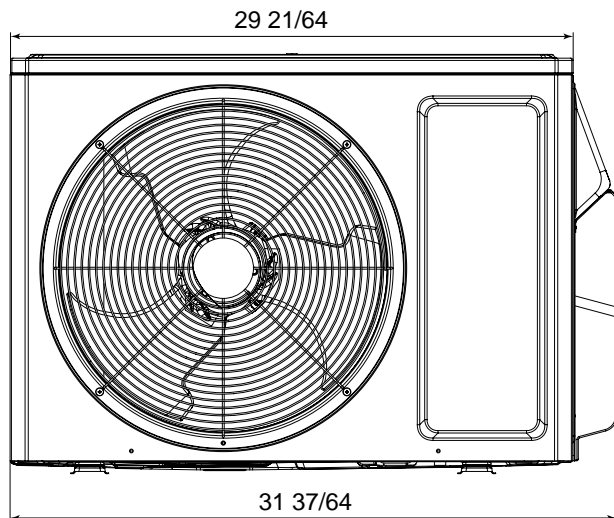
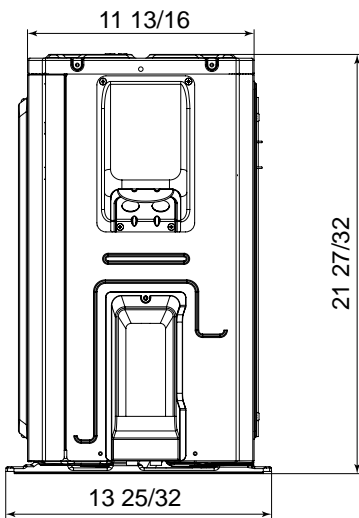

Unit:inch

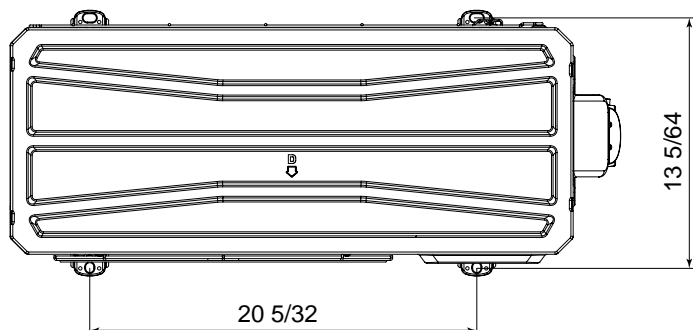

**GWH18ATDXE-D6DNA1C/O GWC24ATEXE-D6DNA1A/O**

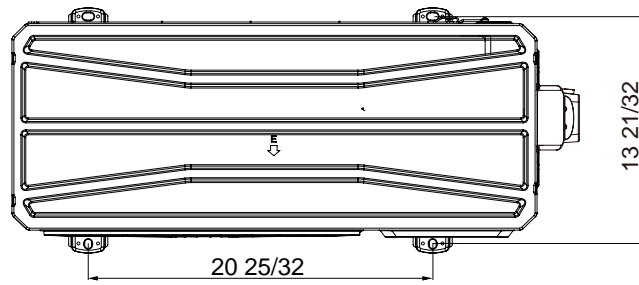
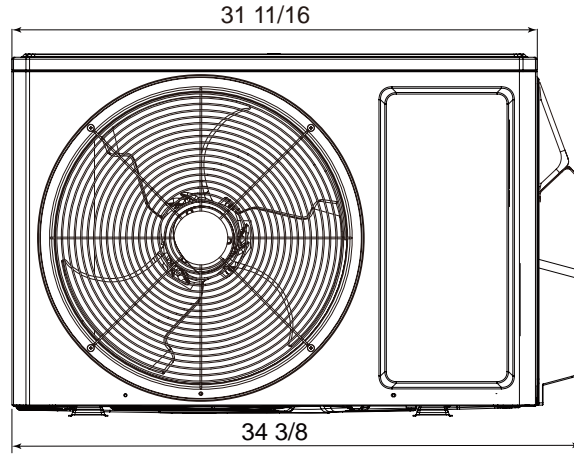
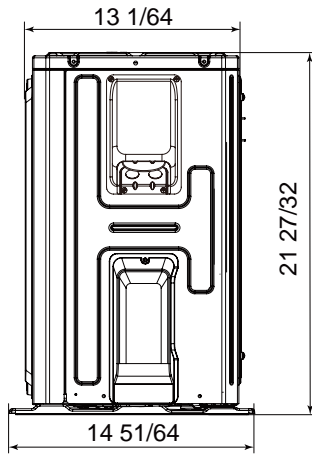

Unit:inch

**LIV24HP230V1R32AO**

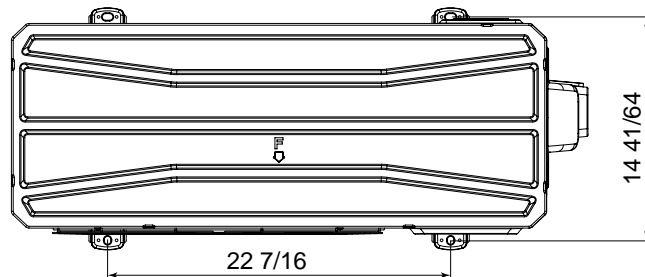
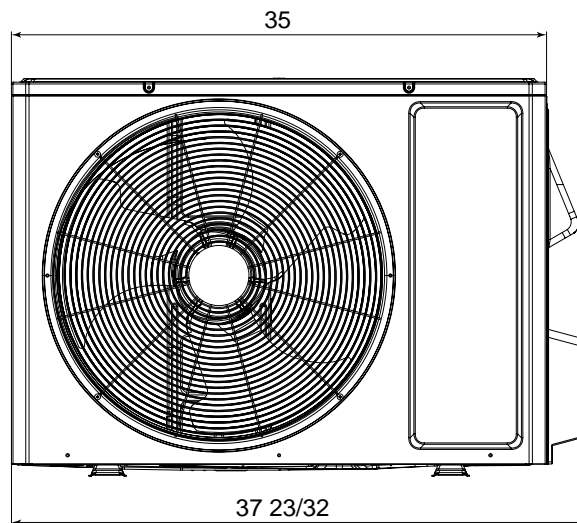
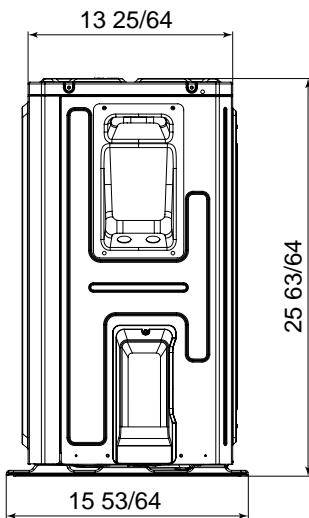

Unit:inch

LIV30HP230V1R32AO, LIV36HP230V1R32AO

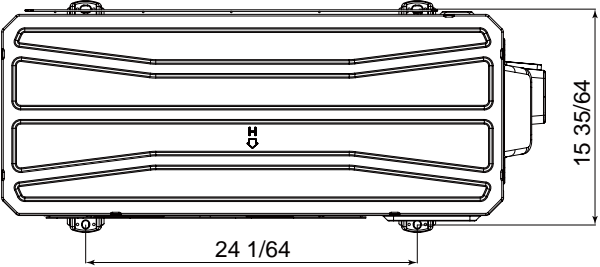
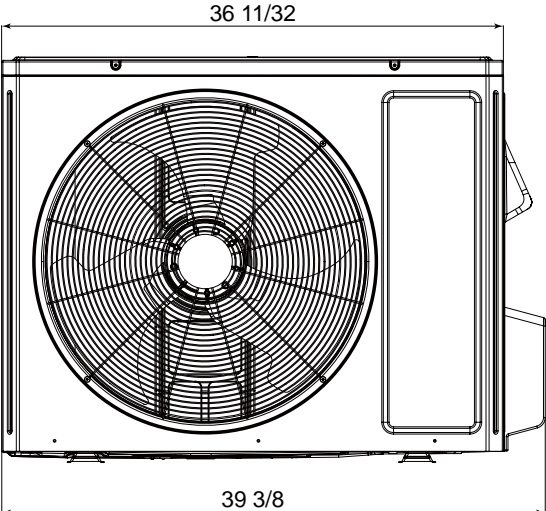
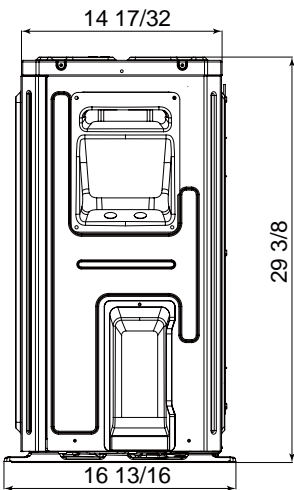

Unit:inch

# 4. Refrigerant System Diagram

GWC09ATCXB-A6DNA1B   GWC09ATCXB-D6DNA1B   GWC09ATCXB-D6DNA4B   GWC12ATCXD-A6DNA4A  
 GWC12ATCXD-D6DNA4A   GWC18ATDXD-D6DNA4C   GWC24ATEXE-D6DNA1A   GWC24ATEXE-D6DNA4A  
 GWC09ATCXB-A6DNA1C   GWC09ATCXB-D6DNA1C   GWC12ATCXB-A6DNA1A   GWC12ATCXB-D6DNA1A  
 GWC18ATDXD-D6DNA1A   GWC24ATEXF-D6DNA1F

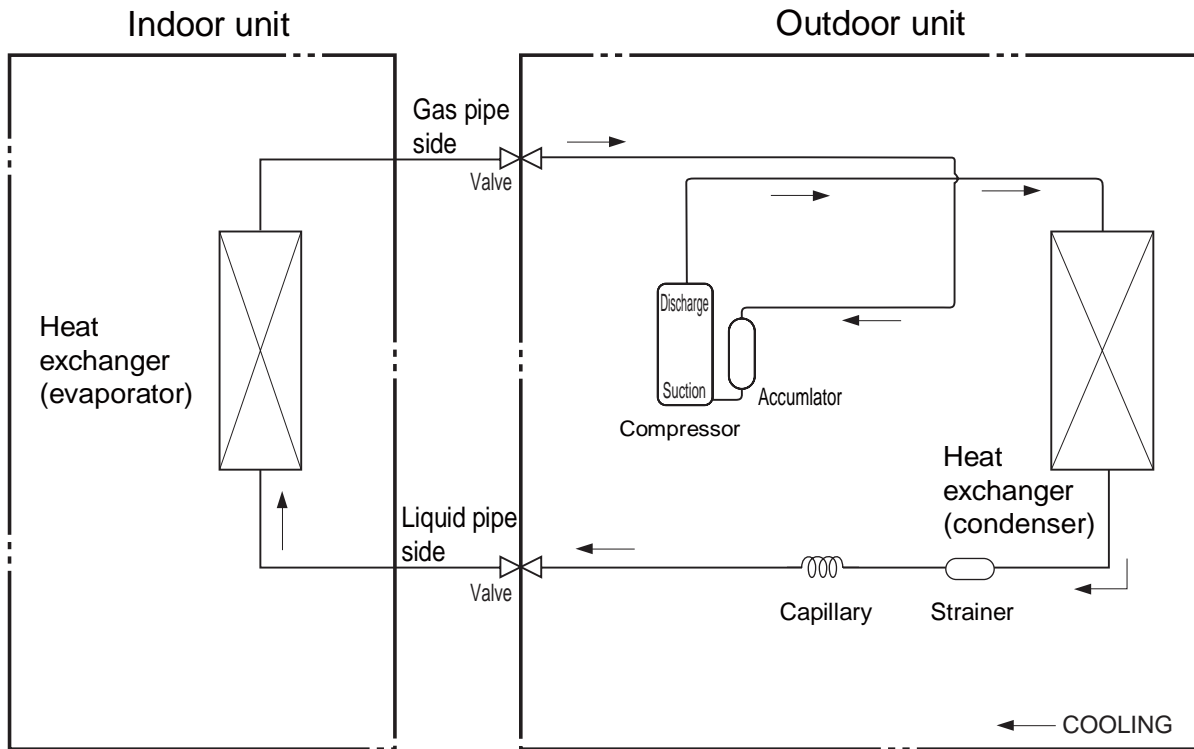

LIV09HP115V1R32A   LIV09HP230V1R32A  
 LIV12HP115V1R32A   LIV12HP230V1R32A

LIV18HP230V1R32A

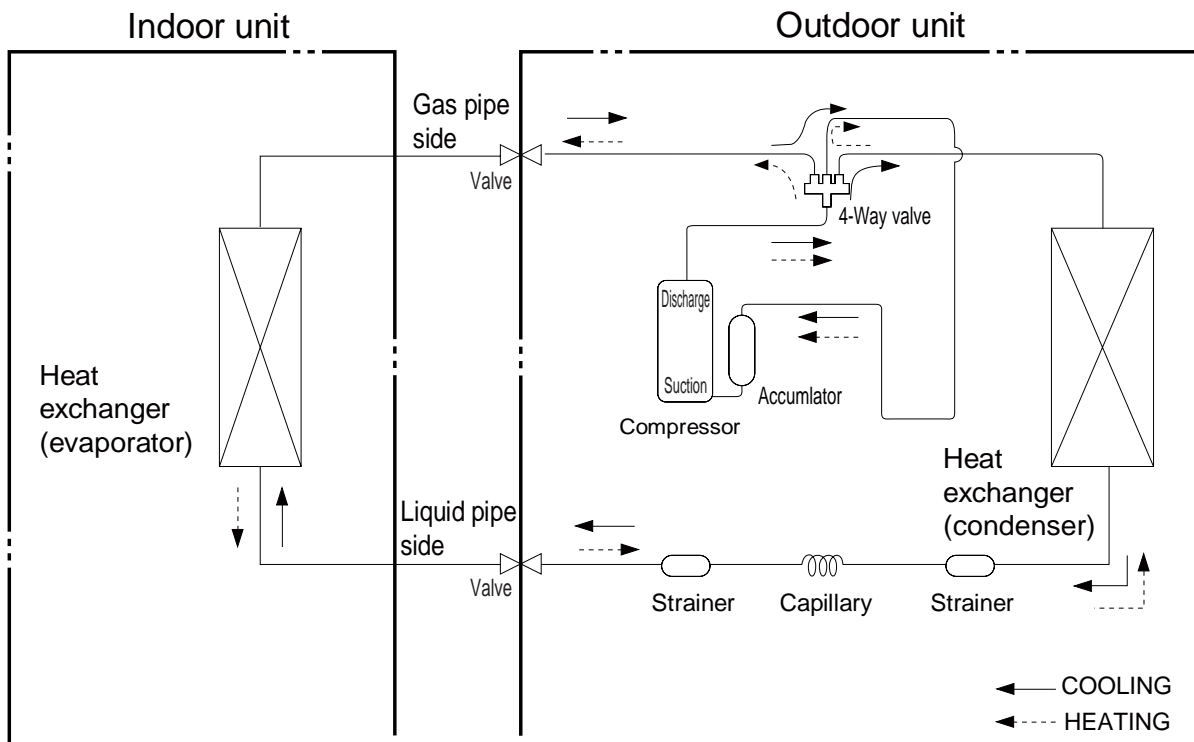

Connection pipe specification:  
 Liquid pipe: 1/4"  
 Gas pipe: 3/8" or 1/2" or 5/8"

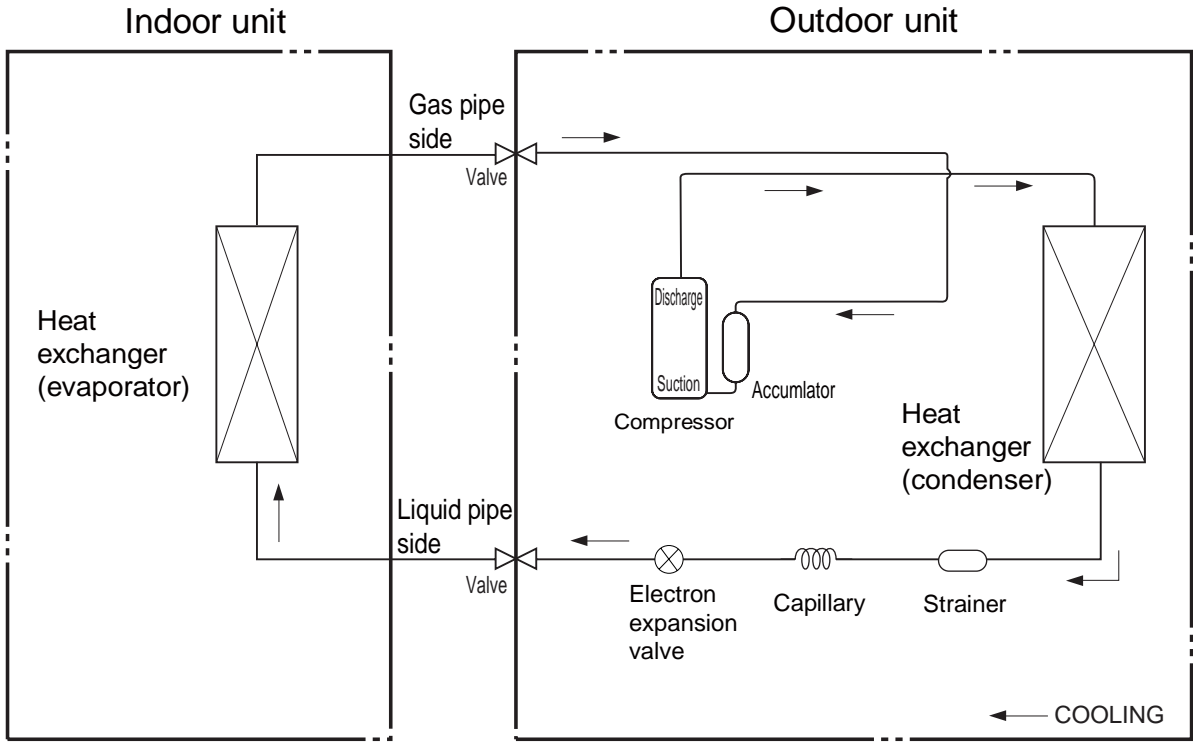

LIV24HP230V1R32A

LIV30HP230V1R32A

LIV36HP230V1R32A

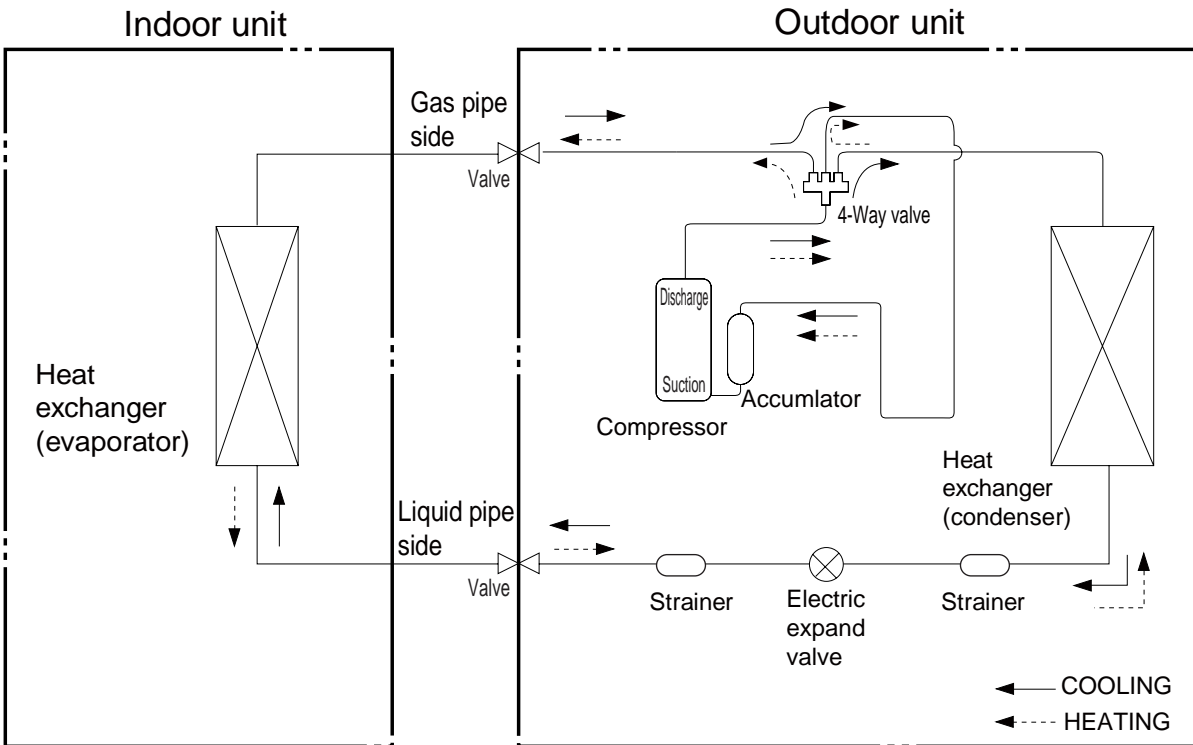

Connection pipe specification:  
 Liquid pipe: 1/4"  
 Gas pipe: 3/8" or 1/2" or 5/8"

# 5. Electrical Part

## 5.1 Wiring Diagram

### • Instruction

Symbol	Symbol Color	Symbol	Symbol Color	Symbol	Name
WH	White	GN	Green	CAP	Jumper cap
YE	Yellow	BN	Brown	COMP	Compressor
RD	Red	BU	Blue	⊕	Grounding wire
YEGN	Yellow/Green	BK	Black	/	/
VT	Violet	OG	Orange	/	/

Note: Jumper cap is used to determine fan speed and the swing angle of horizontal lover for this model.

### • Indoor Unit

GWC09ATCXB-A6DNA1B/I GWH09ATCXB-A6DNA1B/I GWC09ATCXB-D6DNA1B/I GWC09ATCXB-D6DNA4B/I  
 GWH09ATCXB-D6DNA1B/I GWC12ATCXD-A6DNA1A/I GWC12ATCXD-A6DNA4A/I GWH12ATCXD-A6DNA1B/I  
 GWC12ATCXD-D6DNA1A/I GWC12ATCXD-D6DNA4A/I GWH12ATCXD-D6DNA1B/I GWC18ATDXD-D6DNA1C/I  
 GWC18ATDXD-D6DNA4C/I GWH18ATDXE-D6DNA1C/I GWC24ATEXE-D6DNA1A/I GWC24ATEXE-D6DNA4A/I  
 GWH24ATEXF-D6DNA1G/I GWC36ATEXH-D6DNA1G/I GWH36ATEXH-D6DNA1G/I

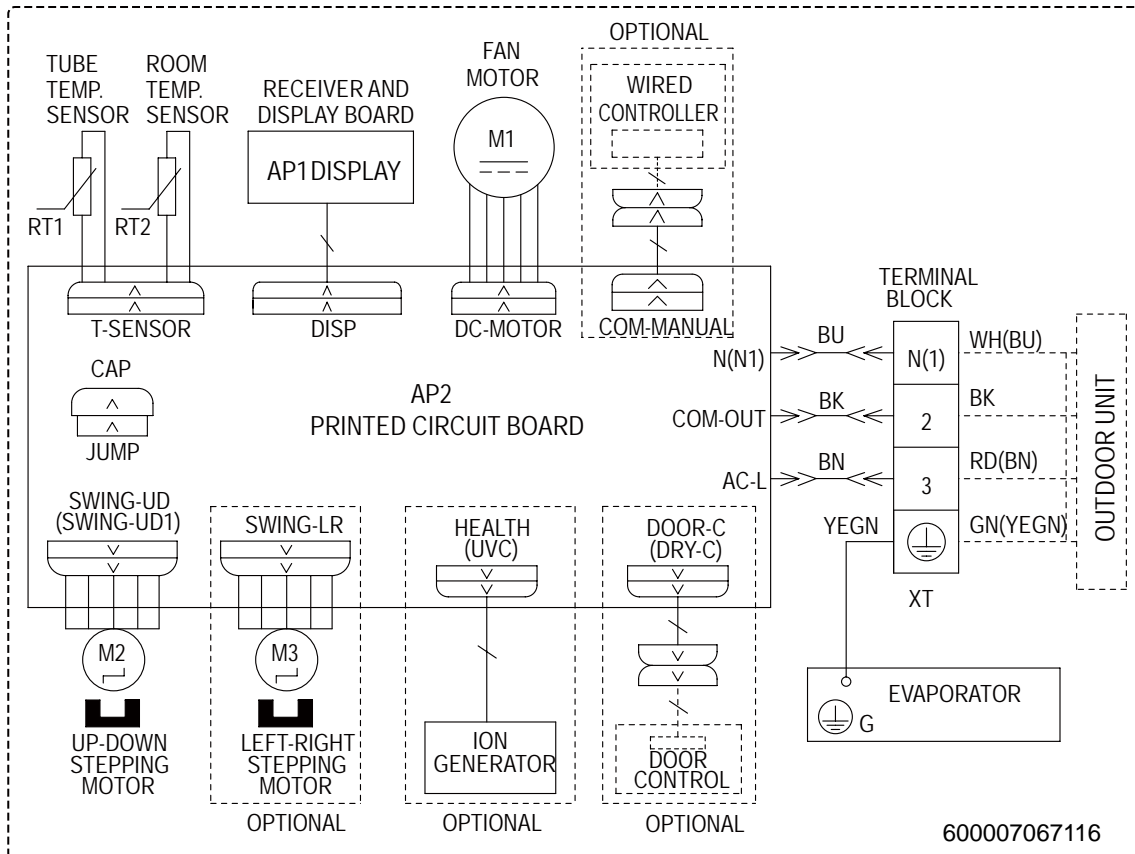



LIV09HP115V1R32AH  
LIV12HP115V1R32AH

LIV09HP230V1R32AH  
LIV12HP230V1R32AH

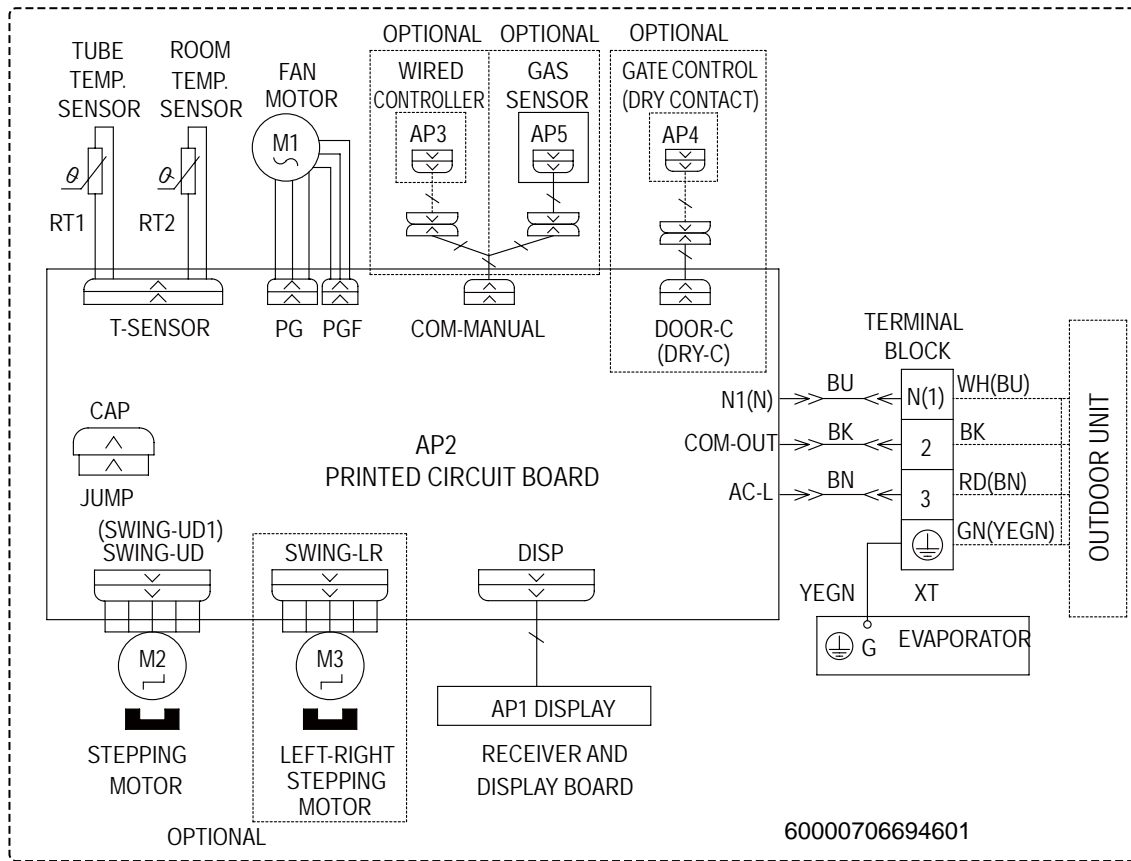

LIV18HP115V1R32AH

LIV24HP230V1R32AH

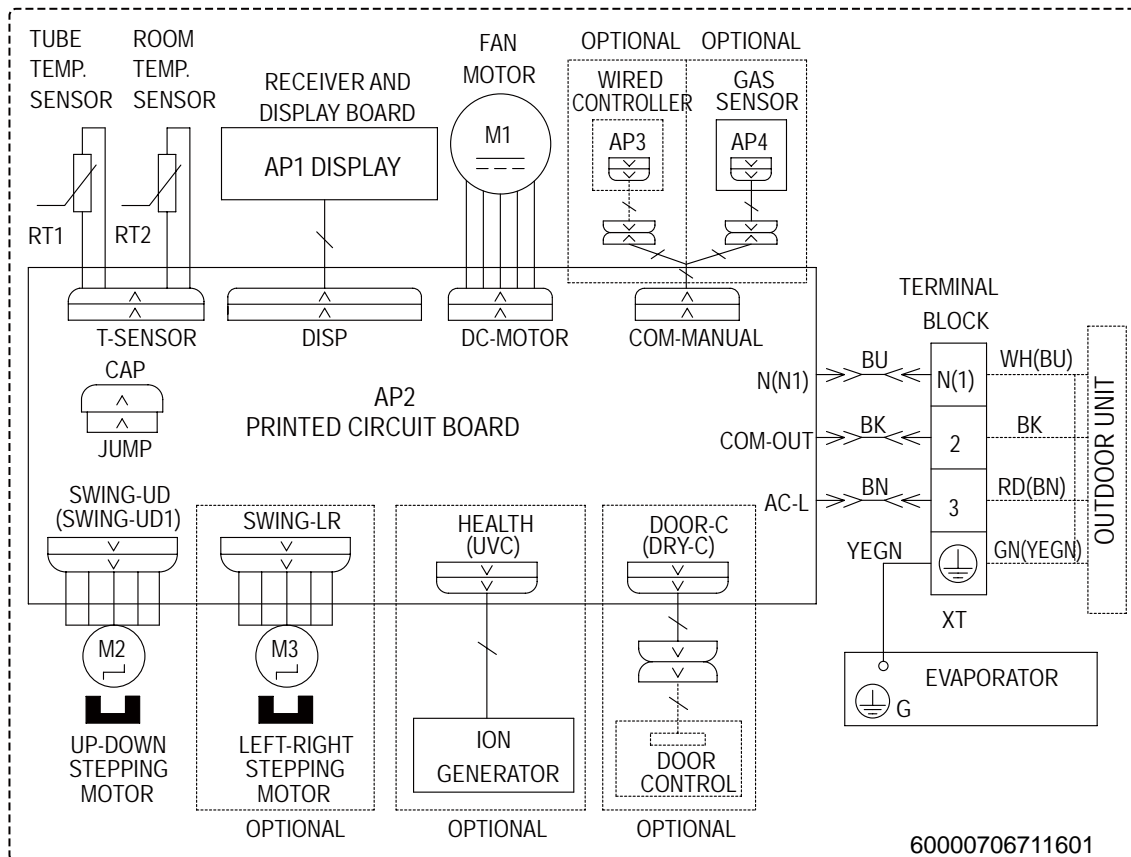

These wiring diagrams are subject to change without notice; please refer to the one supplied with the unit.

● Outdoor Unit

LIV09HP230V1R32AO

LIV12HP230V1R32AO

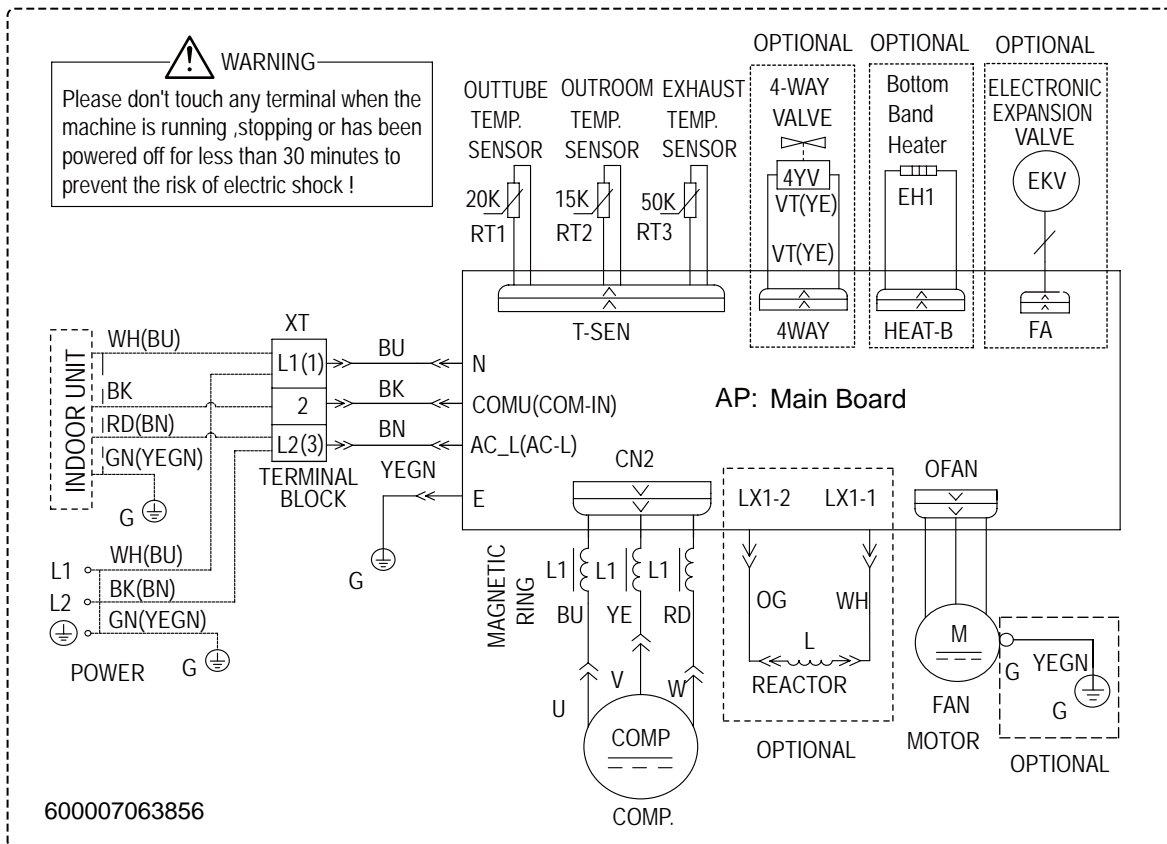

LIV09HP115V1R32AO

LIV12HP115V1R32AO

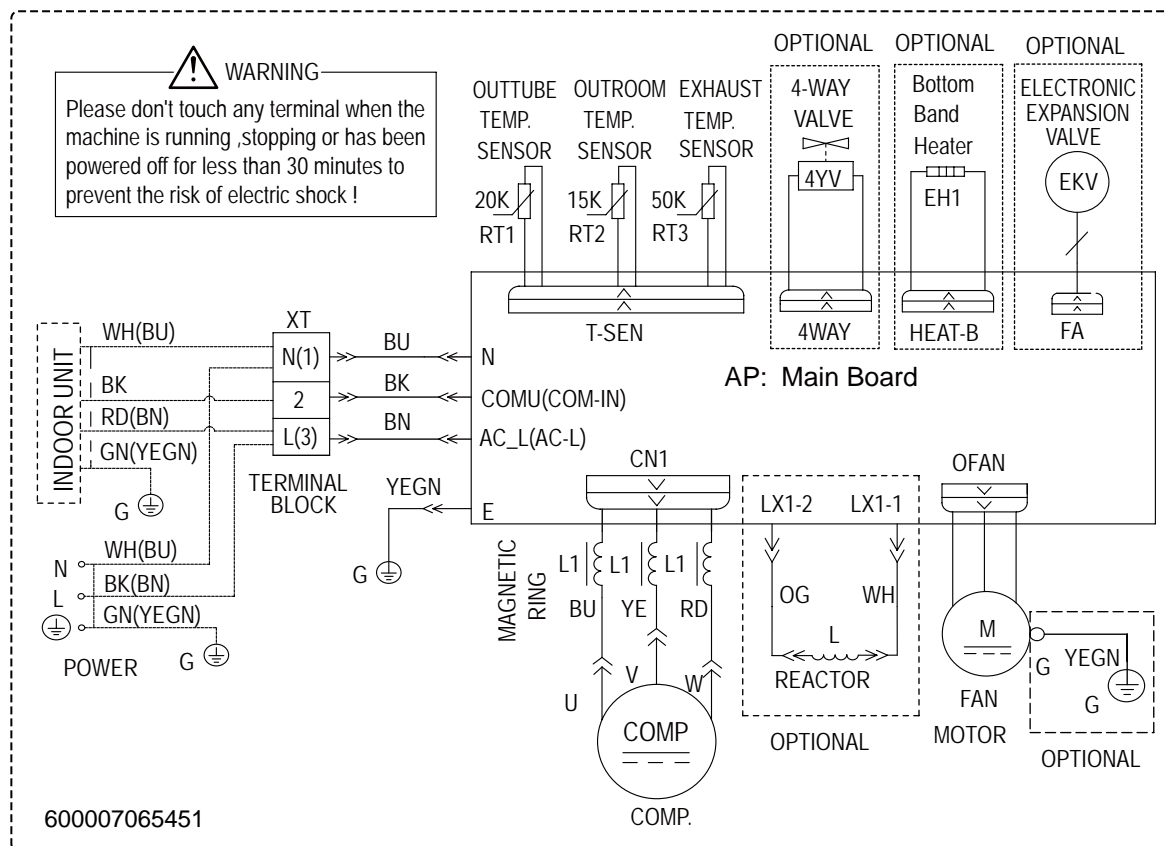

**LIV18HP230V1R32AO**

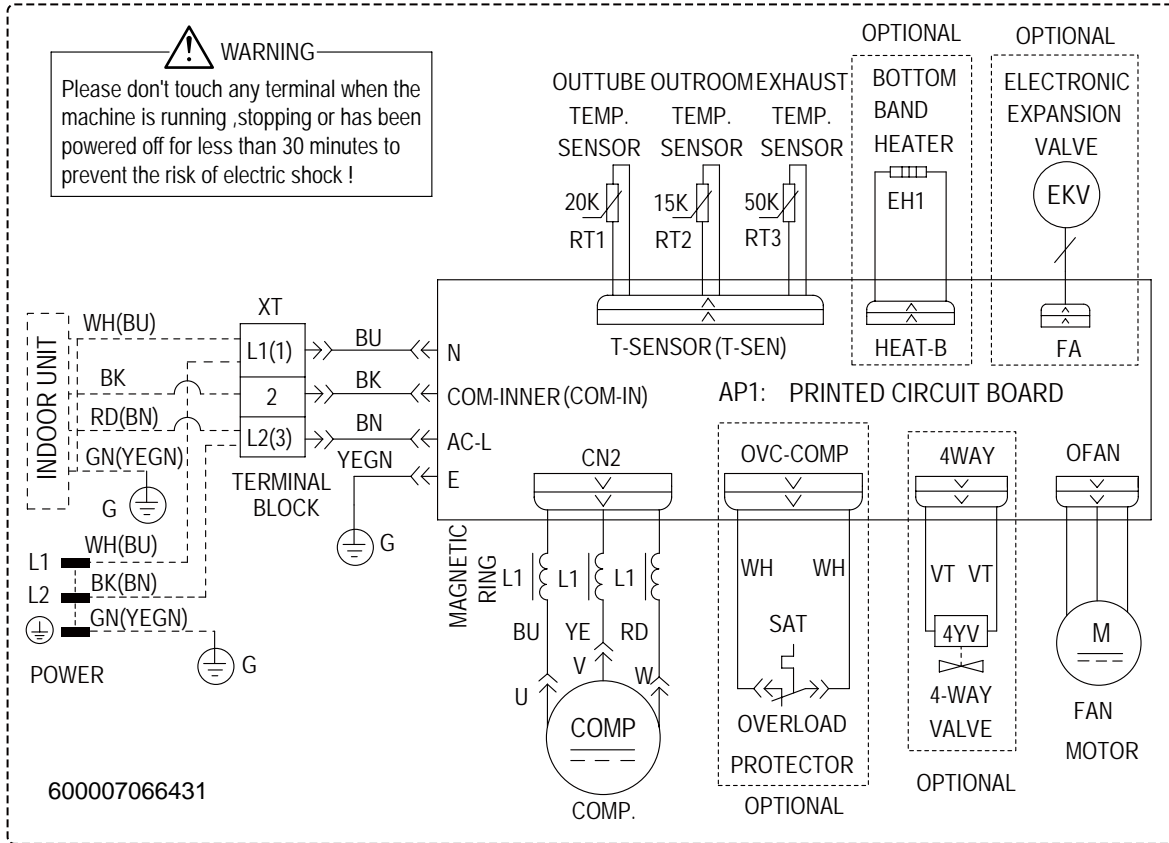

**LIV24HP230V1R32AO**

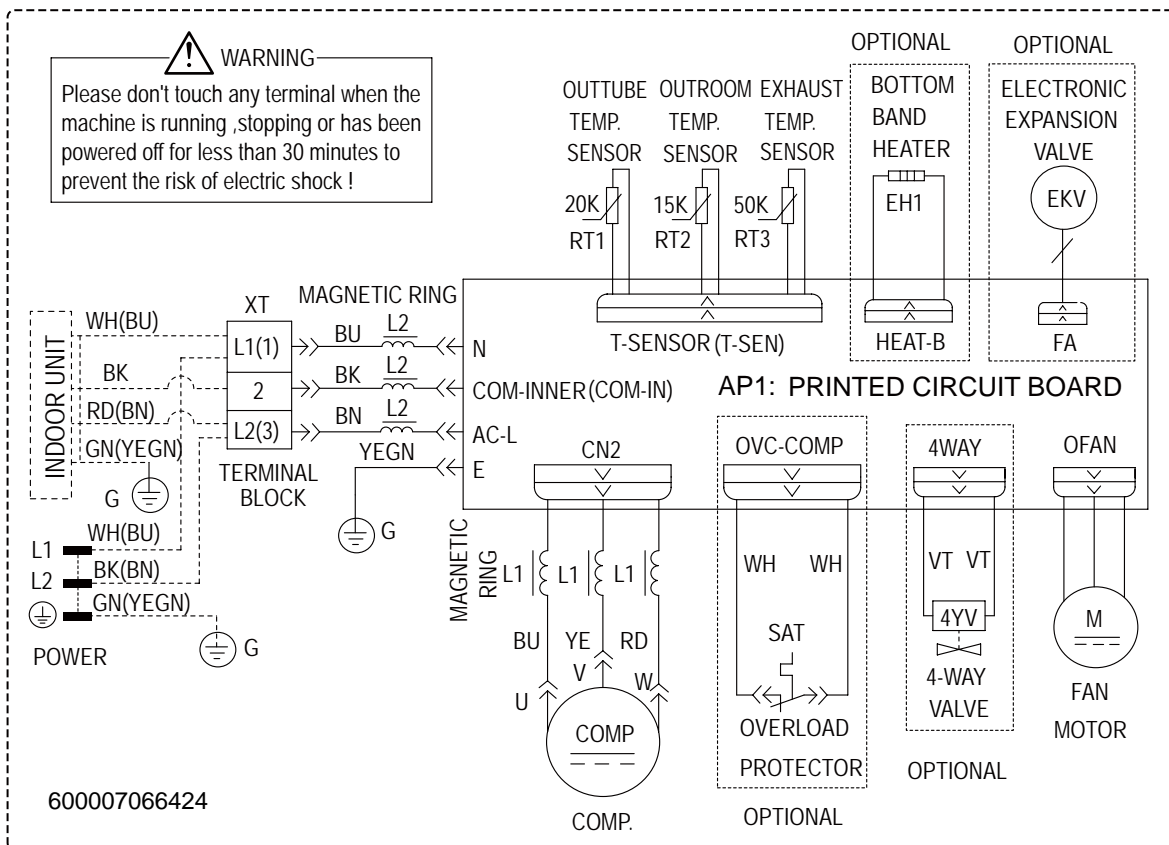

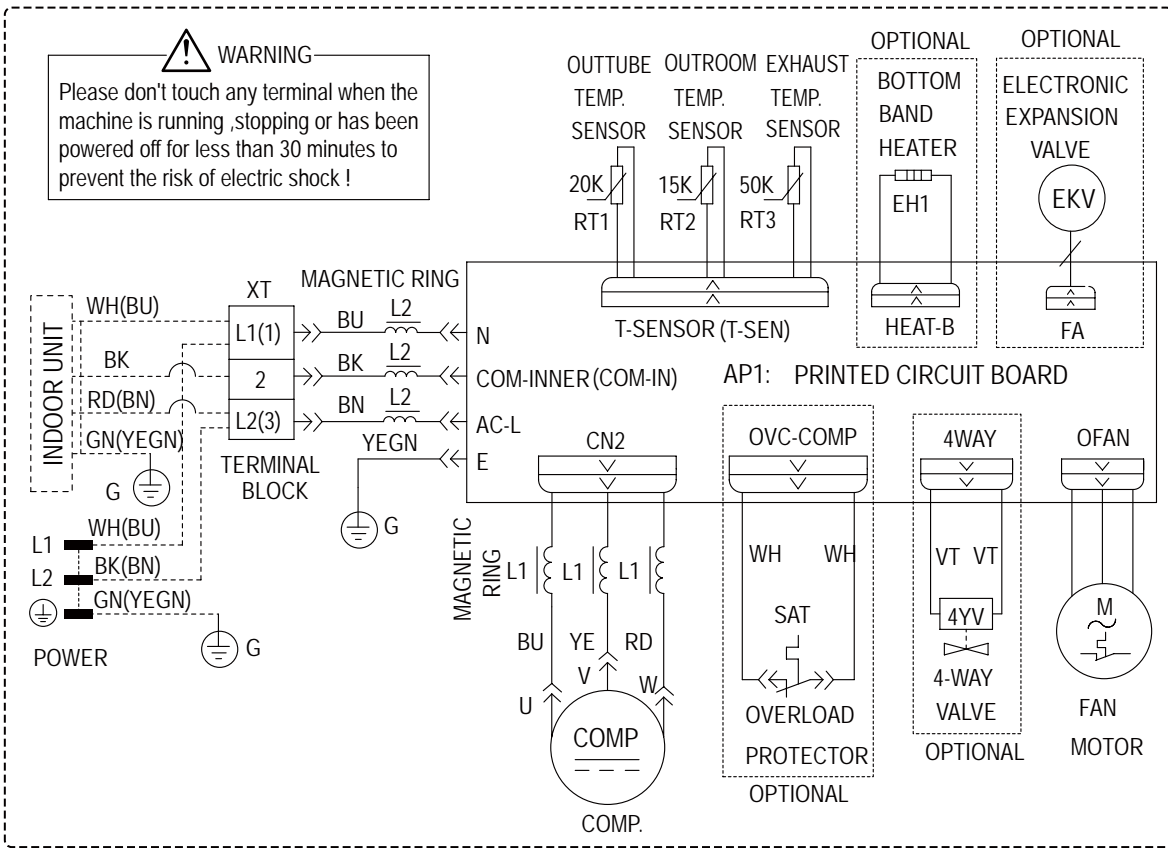

These wiring diagrams are subject to change without notice; please refer to the one supplied with the unit.

## 5.2 PCB Printed Diagram

### Indoor Unit

LIV09HP115V1R32A  
LIV09HP230V1R32A

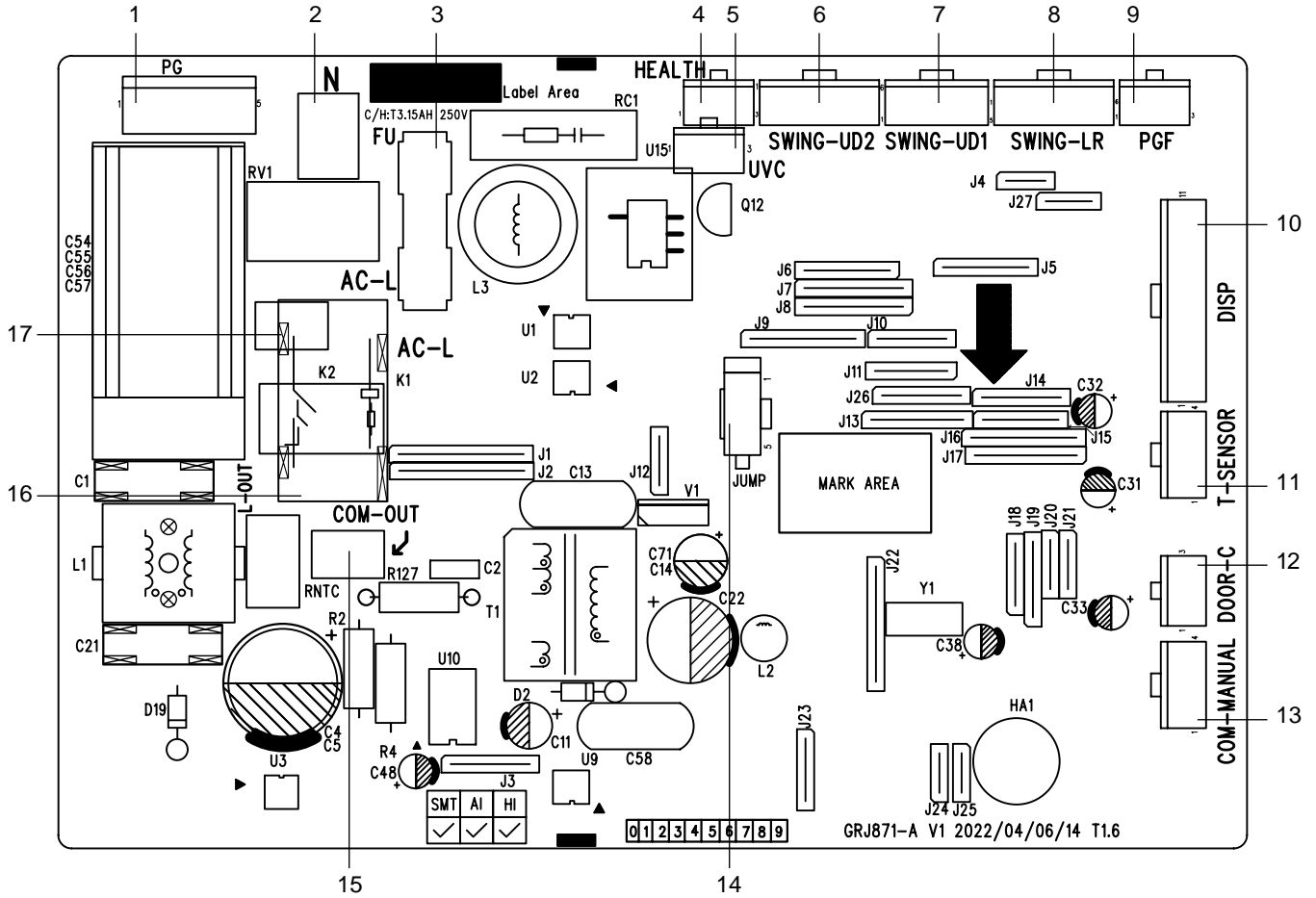

No.	Name	No.	Name
1	PG motor terminal	10	Display board terminal
2	Neutral wire terminal	11	Temperature sensor tube terminal
3	Fuse	12	Door-control terminal
4	Cold plasma terminal	13	Wired controller
5	Ultraviolet cleaning terminal	14	Jumper
6	Up & down swing terminal 2	15	Communication wire terminal
7	Up & down swing terminal 1	16	Live wire terminal (outdoor unit)
8	Left & right swing terminal	17	Live wire terminal
9	PG feedback terminal		

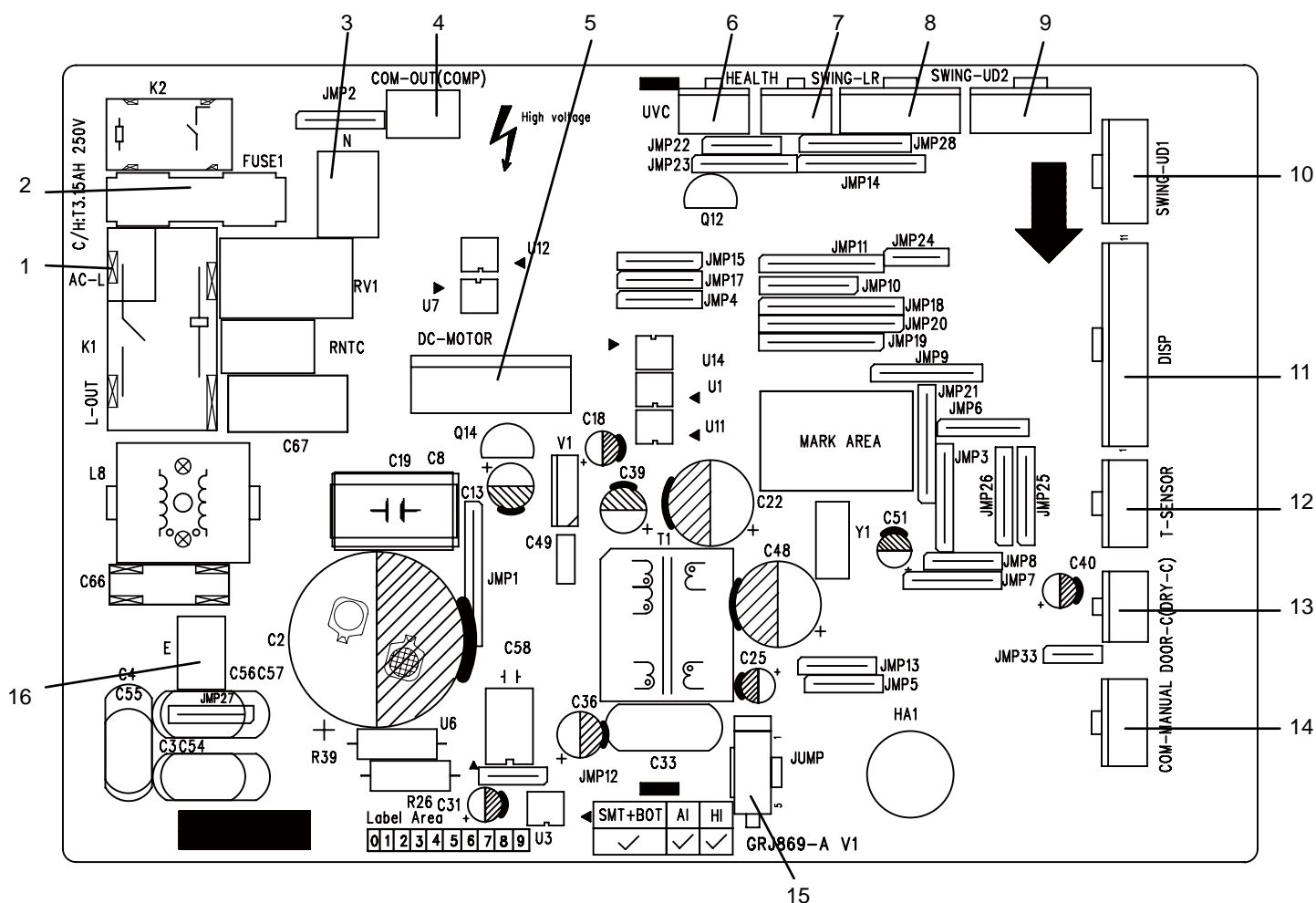

No.	Name
1	Live wire
2	Fuse
3	Neutral wire
4	Communication wire
5	DC fan
6	UVC
7	Cold plasma
8	Left&right swing

No.	Name
9	Up&down swing 2
10	Up&down swing 1
11	Display board
12	Temperature sensor
13	Door control
14	Wired controller
15	Jump
16	Earthing wire

# Outdoor Unit

LIV09HP115V1R32AO    LIV12HP115V1R32AO

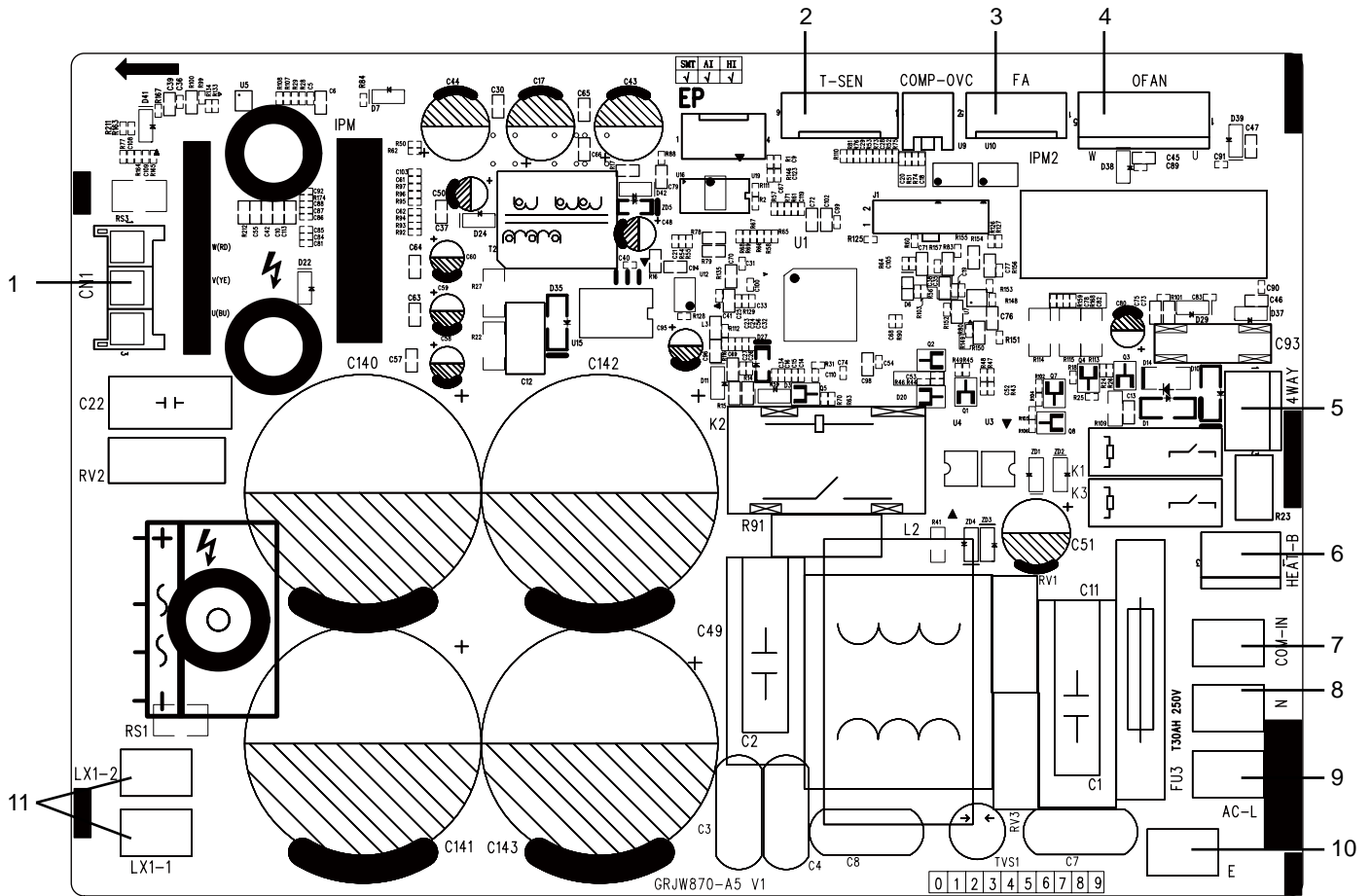

No.	Name
1	Three-phase terminal of compressor
2	Temperature sensor
3	Electronic expansion valve
4	Outdoor fan
5	4-way valve
6	Electric heating of chassis

No.	Name
7	Terminal of communication wire
8	Neutral wire
9	Live wire
10	Earthing wire
11	Interface of reactor

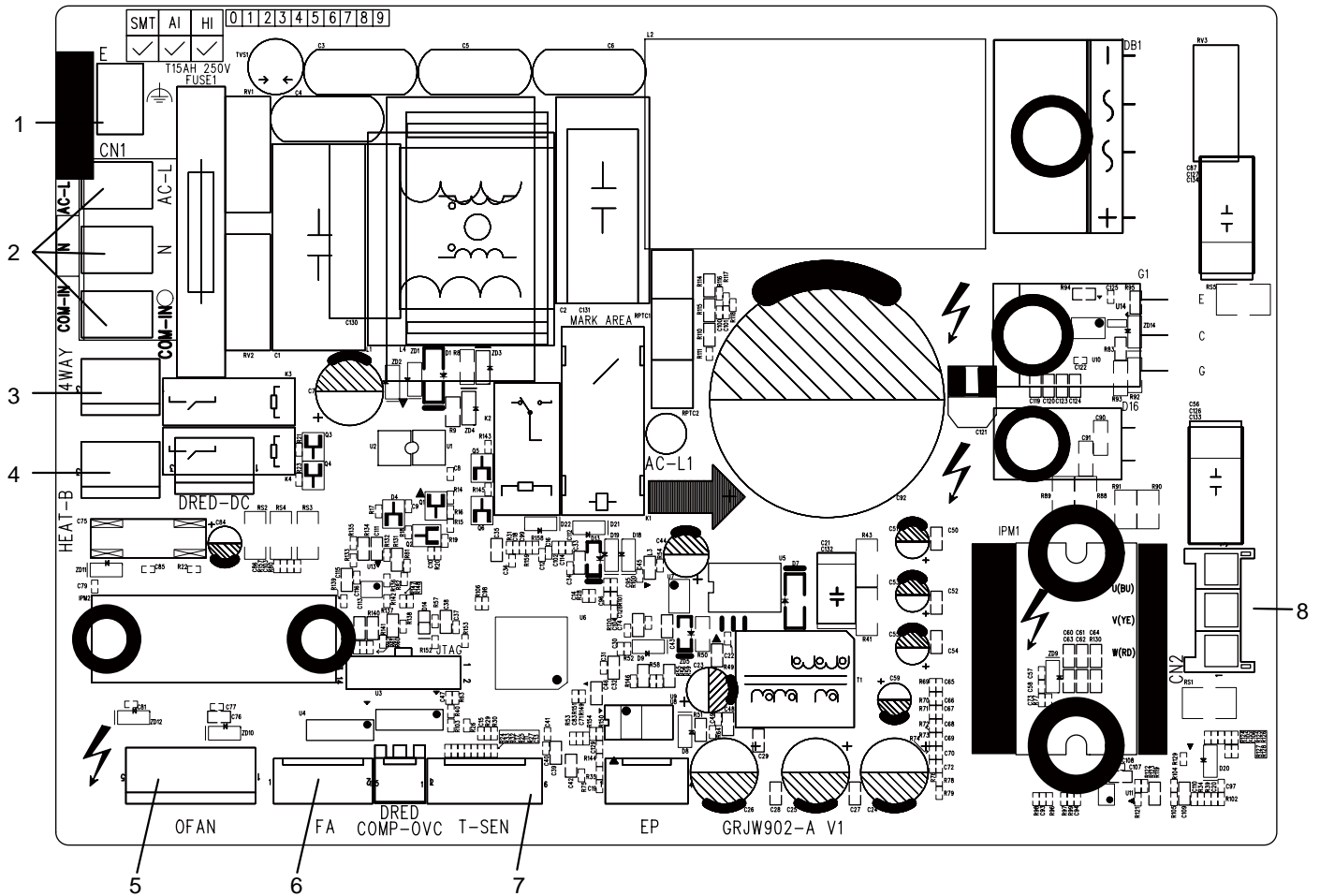

No.	Name
1	Earthing wire
2	Neutral wire, live wire and communication cable
3	4-way valve
4	Electric heating belt of chassis
5	Outdoor fan
6	Electronic expansion valve
7	Temperature sensor
8	Three-phase terminal of compressor



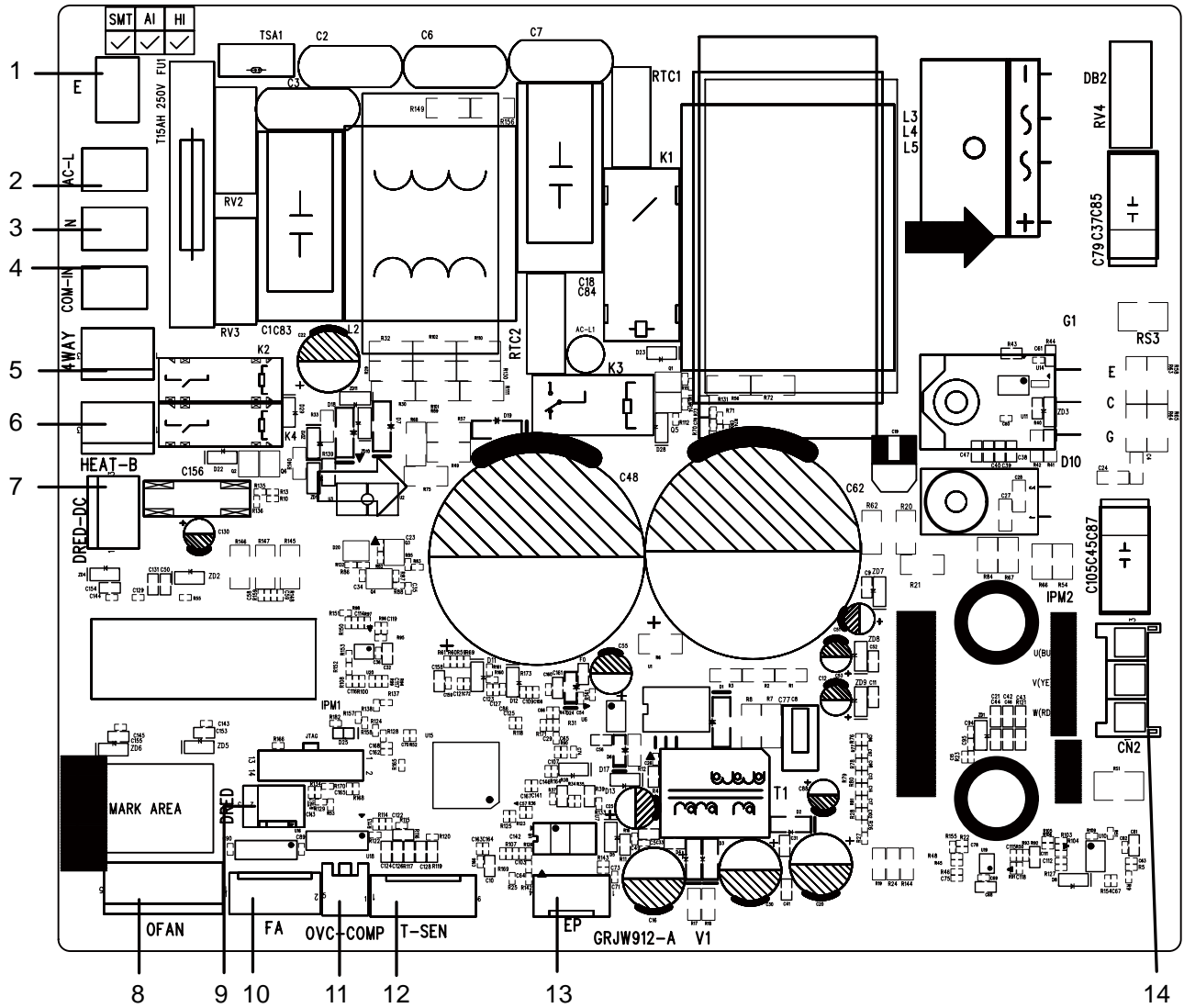

No.	Name	No.	Name
1	Earthing wire	8	Outdoor fan
2	Live wire	9	DRED(Reserved)
3	Neutral wire	10	Electronic expansion valve
4	Communication wire	11	Compressor Overload
5	4-way valve	12	Temperature sensor
6	Electric heating of chassiss	13	E disk
7	DRED-DC(Reserved)	14	Compressor

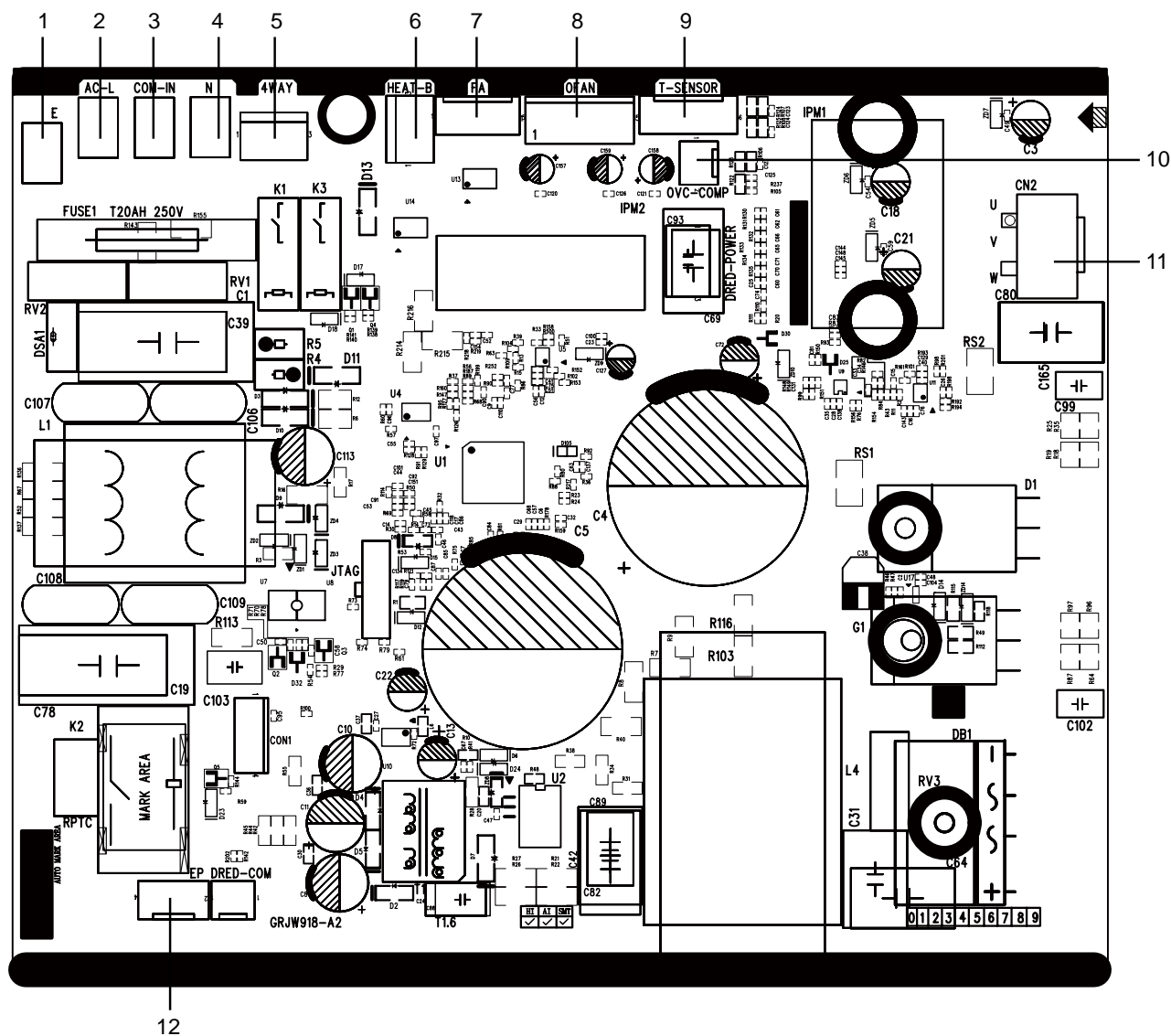

No.	Name
1	Earthing wire
2	Live wire
3	Communication wire
4	Neutral wire
5	4-way valve
6	Electric heating of chassis

No.	Name
7	Electronic expansion valve
8	Fan terminal
9	Temperature sensor
10	Overload of compressor
11	Compressor
12	E disk

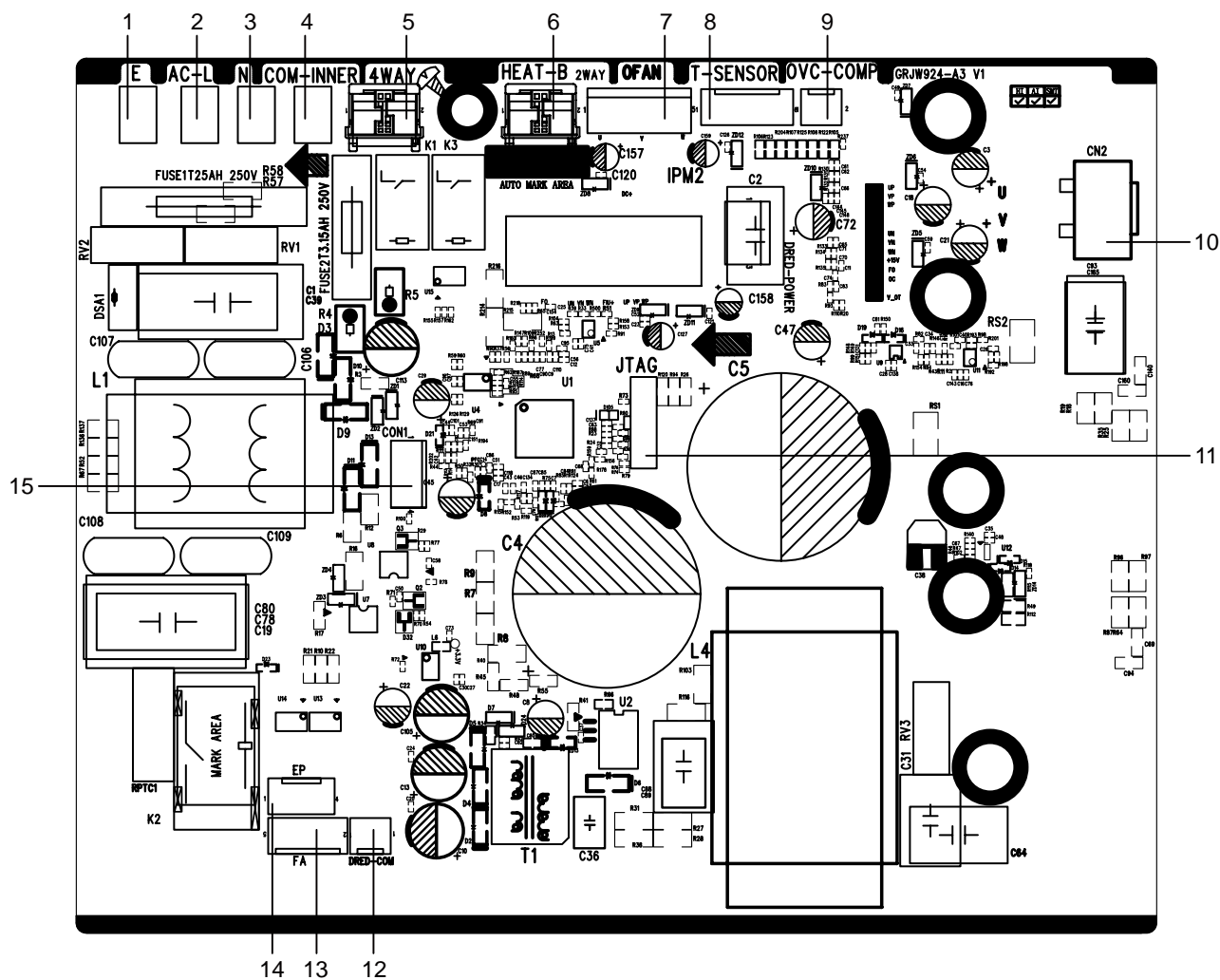

No.	Name	No.	Name
1	Earthing Wire Insertion	9	Compressor Overload Needle Stand
2	Live Wire Insertion	10	Compressor Needle Stand
3	Neutral Wire Insertion	11	Program Debugging Needle Stand
4	Communication Wire Insertion	12	DRED Communication Needle Stand
5	Four-way Valve Needle Stand	13	Electronic Expansion Valve Needle Stand
6	Chassis Electric Heating Belt Needle Stand / Two-way Valve Needle Stand	14	EEP Flash Drive Needle Stand
7	Outdoor Fan Needle Stand	15	Computer Monitor Needle Stand
8	Temperature Sensor Needle Stand		

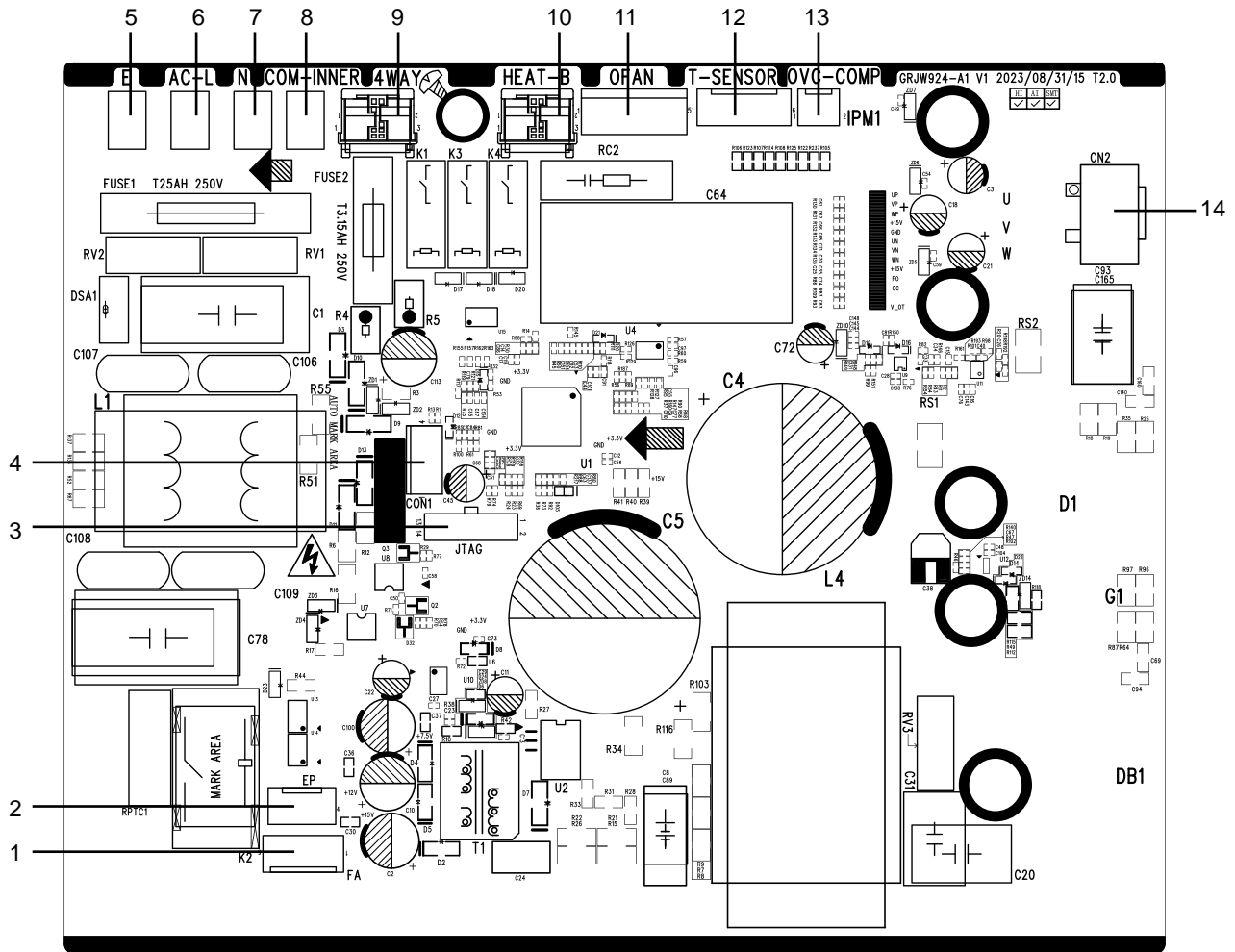

No.	Name
1	Electronic expansion valve
2	E disk
3	Program debug interface
4	Interface monitoring
5	Earthing wire
6	Live wire
7	Neutral wire

No.	Name
8	Communication wire
9	4-way valve
10	Electric heating of chassis
11	AC fan
12	Temperature sensor
13	Overload of compressor
14	Compressor terminal

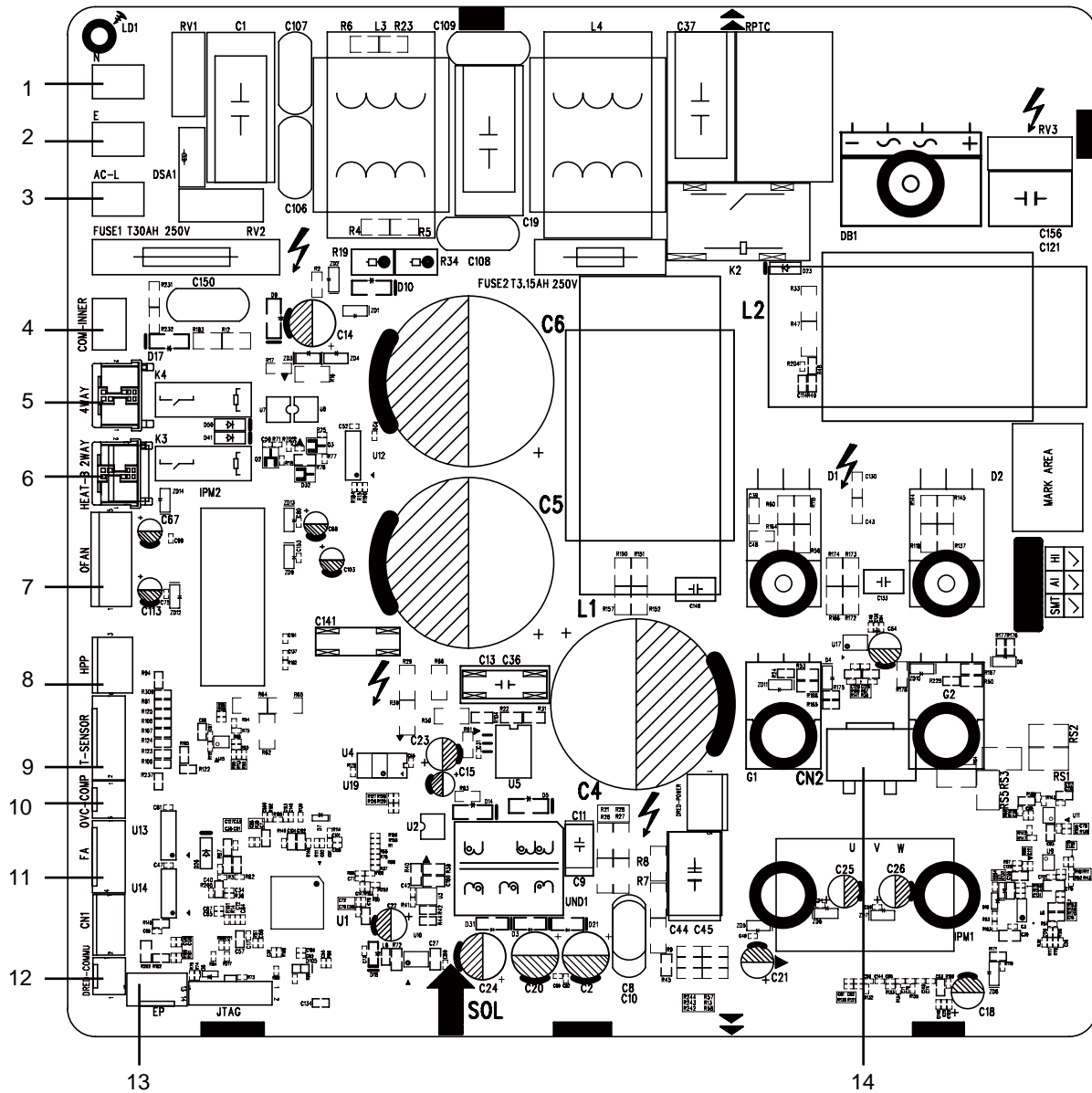

No.	Name	No.	Name
1	Neutral wire	8	Terminal of high pressure protection
2	Grounding wire	9	Temperature sensor
3	Live wire	10	Overload interface of compressor
4	Communication wire	11	Terminal of electronic expansion valve
5	4-way valve	12	Terminal of DRED
6	Electric heating belt of chassis	13	E disk(Reserved)
7	Outdoor fan	14	Terminal of compressor wire

# 6. Function and Control

## 6.1 Remote Controller Introduction

### Buttons on remote controller(YAY1FF)



### Introduction for icons on display screen

	I feel
	Set fan speed
	Turbo mode
	Send signal
	Auto mode
	Cool mode
	Dry mode
	Fan mode
	Heat mode
	Sleep mode
	Light
	Power limiting operation
	X-FAN function
	Indoor ambient temp.
	Clock
	Set temperature
	WiFi function
	Set time
	TIMER ON / TIMER OFF
	Left & right swing
	Up & down swing
	Child lock
	Quiet

#### NOTE:

• This is a general use remote controller. It could be used for the air conditioner with multifunction. For the functions which the model doesn't have, if press the corresponding button on the remote controller, the unit will keep the original

running status.

• After putting through the power, the air conditioner will give out a sound. Power indicator "⏻" is ON. After that, you can operate the air conditioner by using remote controller.

• Under on status, pressing the button on the remote controller, the signal icon "📶" on the display of remote controller will blink once and the air conditioner will give out a "di" sound, which means the signal has been sent to the air conditioner.

#### button

Press this button to turn on the unit. Press this button again to turn off the unit.

#### MODE button

Press this button to select your required operation mode:

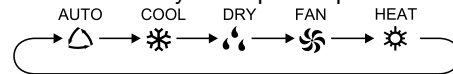

• When selecting auto mode, air conditioner will operate automatically according to ambient temperature. Set temperature can't be adjusted and will not be displayed as well. Press "FAN" button can adjust fan speed. Press "SWING" button can adjust fan blowing angle.

• When selecting cool mode, air conditioner will operate under cool mode. Press "+" or "-" button to adjust set temperature. Press "FAN" button to adjust fan speed. Press "SWING" button to adjust fan blowing angle.

• When selecting dry mode, the air conditioner operates at low speed under dry mode. Under dry mode, fan speed can't be adjusted. Press "SWING" button to adjust fan blowing angle.

• When selecting fan mode, the air conditioner will only blow fan, no cooling and no heating. Press "FAN" button to adjust fan speed. Press "SWING" button to adjust fan blowing angle.

• When selecting heat mode, the air conditioner operates under heat mode. Press "+" or "-" button to adjust set temperature. Press "FAN" button to adjust fan speed. Press "SWING" button to adjust fan blowing angle.

#### NOTE:

• For preventing cold air, after starting up heat mode, indoor unit will delay 1~5 minutes to blow air (Actual delay time depends on indoor ambient temperature).

• Set temperature range from remote controller: 16~30°C (61~86°C).

• This mode indicator is not available for some models.

• Cooling only unit won't receive heat mode signal. If setting heat mode with remote controller, press "⏻" button can't start up the unit.

#### FAN button

This button is used for setting Fan Speed in the sequence that goes from AUTO, then back to Auto.

#### NOTE:

• Under AUTO speed, air conditioner will select proper fan speed

automatically according to factory default setting.

- It's low fan speed under dry mode.
- X-FAN function: Holding fan speed button for 2s in cool or dry mode, the icon "☼" is displayed and the indoor fan will continue operation for a few minutes in order to dry the indoor unit even though you have turned off the unit. After energization, X-FAN OFF is defaulted. X-FAN is not available in auto, fan or heat mode.

This function indicates that moisture on evaporator of indoor unit will be blown after the unit is stopped to avoid mould.

- Having set X-FAN function on: After turning off the unit by pressing "⏻" button, indoor fan will continue running for a few minutes at low speed. In this period, hold fan speed button for 2s to stop indoor fan directly.

Having set X-FAN function off: After turning off the unit by pressing "⏻" button, the complete unit will be off directly.

- If equipped with the product of 4 kinds of fan speed, when setting "🌀", "■", the unit will work in low speed; when setting "■", "■", "■", the unit will work in medium speed; when setting "■", "■", "■", "■", the unit will work in high speed.

#### - / + button

Press "+" or "-" button once increase or decrease set temperature 1°C(°F). Holding "+" or "-" button, 2s later, set temperature on remote controller will change quickly. On releasing button after setting is finished, temperature indicator on indoor unit will change accordingly. (Temperature can't be adjusted under auto mode) When setting TIMER ON, TIMER OFF or CLOCK, press "+" or "-" button to adjust time. (Refer to CLOCK, TIMER ON, TIMER OFF functions).

#### MENU button

Press this button to select submenu function and then press "SET" button to set the function status of submenu. The submenu can be selected circularly as follows:

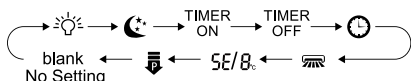

#### NOTE:

- Some menu's function may be unavailable under different models.

#### Light function

When selecting light function, light icon "☼" flashes for 5s; press "SET" button within 5s to turn off display light on indoor unit and "☼" icon on remote controller disappears. Press "SET" button again within 5s to turn on display light and "☼" icon is displayed.

#### Sleep function

When selecting sleeping function, sleeping icon "☾" flashes for 5s; press "SET" button within 5s can select Sleep 1 (☾1), Sleep 2 (☾2), Sleep 3 (☾3) and cancel Sleep circularly.

- Sleep 1 is Sleep mode 1, in Cool modes; sleep status after run for one hour, the main unit setting temperature will increase 1°C, two hours, setting temperature increased 2°C, then the unit will run at this setting temperature; In Heat mode: sleep status after run for one hour, the setting temperature will decrease 1°C, two hours, setting temperature will decrease 2°C, then the unit will run

at this setting temperature.

- Sleep 2 is sleep mode 2, that is air conditioner will run according to the presetting a group of sleep temperature curve.
- Sleep 3-the sleep curve setting under Sleep mode by DIY;  
(1) Under Sleep 3 mode, press "Turbo" button for a long time, remote controller enters into user individuation sleep setting status, at this time, the time of remote controller will display "1hour", the setting temperature "88" will display the corresponding temperature of last setting sleep curve and blink (The first entering will display according to the initial curve setting value of original factory);  
(2) Adjust "+" and "-" button, could change the corresponding setting temperature, after adjusted, press "Turbo" button for confirmation;  
(3) At this time, 1hour will be automatically increased at the timer position on the remote control, (that are "2hours" or "3hours" or "8hours"), the place of setting temperature "88" will display the corresponding temperature of last setting sleep curve and blink;  
(4) Repeat the above step (2)~(3) operation, until 8 hours temperature setting finished, sleep, curve setting finished, at this time, the remote controller will resume the original timer display; temperature display will resume to original setting temperature.

- Sleep3- the sleep curve setting under Sleep mode by DIY could be inquired:

The user could accord to sleep curve setting method to inquire the presetting sleep curve, enter into user individuation sleep setting status, but do not change the temperature, press "Turbo" button directly for confirmation. Note: In the above presetting or enquiry procedure, if continuously within 10s, there is no button pressed, the sleep curve setting within 10s, there is no button pressed, the sleep curve setting status will be automatically quit and resume to display the original displaying. In the presetting or enquiry procedure, press "⏻" button, "MODE" button, the sleep curve setting or enquiry status will quit similarly.

#### NOTE:

- If equipped with the product with one kind of sleeping mode only, set Sleep 1 (☾1) or Sleep 3 (☾3) to activate sleeping function.

#### TIMER ON function

TIMER ON function can set the time for timer on. Under TIMER ON function status, "⌚" icon disappears and the word "ON" on remote controller blinks. Press "+" or "-" button to adjust TIMER ON setting. After each pressing "+" or "-" button TIMER ON setting will increase or decrease 1min. Hold "+" or "-" button, 2s later, the time will change quickly until reaching your required time. Press "SET" button to confirm it within 5S. The word "ON" will stop blinking.

Cancel TIMER ON: Press "MENU" button to TIMER ON function and the characters "ON" flashes on the remote controller; press "SET" button until the characters "ON" disappears.

#### TIMER OFF function

TIMER OFF function can set the time for timer off. Under TIMER OFF function status, "⌚" icon disappears and the word "OFF" on remote controller blinks. Press "+" or "-" button to adjust TIMER OFF setting. After each pressing "+" or "-" button TIMER OFF setting will increase or decrease 1min. Hold "+" or "-" button, 2s later, the time will change quickly until reaching your required time, press "SET" button to confirm it within 5S. The

word "OFF" will stop blinking.

Cancel TIMER OFF: Press "MENU" button to TIMER OFF function and the characters "OFF" flashes on the remote controller; press "SET" button until the characters "OFF" disappears.

#### **CLOCK function**

CLOCK function can set clock time. Under CLOCK function status, "⌚" icon on remote controller will blink. Press "+" or "-" button within 5s to set clock time. Each pressing of "+" or "-" button, clock time will increase or decrease 1 min. If hold "+" or "-" button, 2s later, time will change quickly.

Release this button when reaching your required time, press "SET" button to confirm it within 5S. The "⌚" icon will stop blinking.

#### **Left & right swing function**

When selecting left & right swing function, left & right swing icon "↔" flashes for 5s; press "SET" button within 5s to select left & right swing angle.

Fan blow angle can be selected circularly as below:

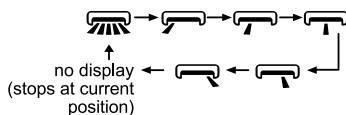

NOTE:

- The function is only available for some models.

#### **Energy-saving function**

Under cooling mode, when selecting energy-saving function, energy-saving function icon "⚡" flashes for 5s; press "SET" button within 5s to turn on or turn off energy-saving function. When energy-saving function is started up, "SE" will be shown on remote controller, and air conditioner will adjust the set temperature automatically according to ex-factory setting to reach to the best energy-saving effect. Press "SET" button again to exit energy-saving function.

#### **8°C-heating function**

Under heating mode, when selecting 8°C-heating function, 8°C-heating icon "8°C" flashes for 5s; press "SET" button within 5s to turn on or turn off 8°C-heating. When 8°C-heating is started up, "8°C" will be shown on remote controller, and the air conditioner keep the heating status at 8°C. Press "SET" button again to exit 8°C-heating function.

NOTE:

Under °F temperature display, the remote controller will display 46°F heating.

#### **Power limiting function**

Power limiting function is for limiting the power of the whole unit. When selecting power limiting function, power limiting icon "⚡" flashes for 5s; press "SET" button within 5s and the remote controller will circularly display as follows:

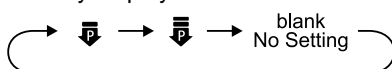

- Maximum power limited under the ⚡ mode is lower than that of ⚡ mode.
- If the current power is lower than the maximum power of ⚡ mode, then the power will not be limited after entering into such mode.
- For the model with one outdoor unit and two indoor units, if any

one of indoor units enters into power limiting function, the outdoor unit will enter into the set limiting power mode of indoor unit; when two indoor units enter into power limiting mode, then the power of outdoor unit will be limited according to the lower power of the two indoor units.

NOTE:

- The function is only available for some models.

#### **SWING button**

Press this button can select up & down swing angle. Fan blow angle can be selected circularly as below:

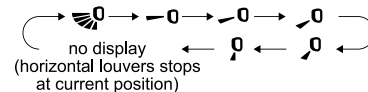

- When selecting "↕", air conditioner is blowing fan automatically. Horizontal louver will automatically swing up & down at maximum angle.
- When selecting "↔", air conditioner is blowing fan at fixed position. Horizontal louver will stop at the fixed position.
- Hold "↕" button above 2s to set your required swing angle. When reaching your required angle, release the button.

NOTE:

- Press this button continuously for more than 2s, the main unit will swing back and forth from up to down, and then loosen the button, the unit present position of guide louver will be kept immediately.
- Under up and down swing mode, when the status is switched from off to ↕, if press this button again 2s later, ↕ status will switch to off status directly; if press this button again within 2s, the change of swing status will also depend on the circulation sequence stated above.

#### **TURBO button**

Under COOL or HEAT mode, press this button to turn to quick COOL or quick HEAT mode. "⚡" icon is displayed on remote controller. Press this button again to exit turbo function and "⚡" icon will disappear. If start this function, the unit will run at super-high fan speed to cool or heat quickly so that the ambient temperature approaches the preset temperature as soon as possible.

### **Function introduction for combination buttons**

#### **Child lock function**

Press "+" and "-" simultaneously to turn on or turn off child lock function. When child lock function is on, "🔒" icon is displayed on remote controller. If you operate the remote controller, the "🔒" icon will blink three times without sending signal to the unit.

#### **Temperature display switchover function**

Under OFF status, press "-" and "MODE" buttons simultaneously to switch temperature display between °C and °F.

#### **Auto clean function**



Under unit off status, hold "MODE" and "FAN" buttons simultaneously for 5s to turn on or turn off the auto clean function. When the auto clean function is turned on, indoor unit displays "CL". During the auto clean process of evaporator, the unit will perform fast cooling or fast heating. There may be some noise, which is the sound of flowing liquid or thermal expansion or cold shrinkage. The air conditioner may blow cool or warm air, which is a normal phenomenon. During cleaning process, please make sure the room is well ventilated to avoid affecting the comfort.

**NOTE:**

- The auto clean function can only work under normal ambient temperature. If the room is dusty, clean it once a month; if not, clean it once every three months. After the auto clean function is turned on, you can leave the room. When auto clean is finished, the air conditioner will enter standby status.
- This function is only available for some models.

**WiFi function**

Press "MODE" and "TURBO" button simultaneously to turn on or turn off WiFi function. When WiFi function is turned on, the "WiFi" icon will be displayed on remote controller; Long press "MODE" and "TURBO" buttons simultaneously for 10s, remote controller will send WiFi reset code and then the WiFi function will be turned on. WiFi function is defaulted ON after energization of the remote controller.

**NOTE:**

- This function is only available for some models.

**Ambient temperature display function**

UPress "SWING" and "SET" buttons simultaneously, you can see indoor ambient temperature on indoor unit's displayer and the "⬆️⬆️" icon will be displayed on remote controller. The setting on remote controller is selected circularly as below:

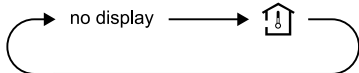

**Adjustable temperature under auto mode**

The remote controller defaulted that the set temperature can't be adjusted and it won't be displayed under AUTO mode; when pressing "+" and "SET" buttons simultaneously under off status for consecutive 5s, the set temperature can be adjusted under AUTO mode. After setting is succeeded, the set temperature on the remote controller flashes for 3 times.

Under cooling or heating mode, when turning on sleep mode and turn to low speed or quiet notch, the outdoor unit would enter into night mode.

**NOTE:**

- When you feel that the cooling and heating effect is poor, please press "FAN" button to other fan speed or press "SLEEP" button to exit the night mode.
- The night mode can only work under normal ambient temperature.
- This function is only available for some models.

**Replacement of batteries in remote controller**

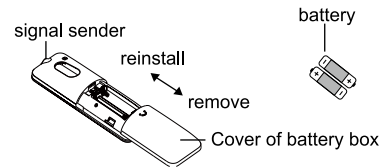

1. Press the back side of remote controller marked with " ", as shown in the fig, and then push out the cover of battery box along the arrow direction.
2. Replace two 7# (AAA 1.5V) dry batteries, and make sure the position of "+" polar and "-" polar are correct.
3. Reinstall the cover of battery box.

**NOTE:**

- During operation, point the remote control signal sender at the receiving window on indoor unit.
- The distance between signal sender and receiving window should be no more than 8m, and there should be no obstacles between them.
- Signal may be interfered easily in the room where there is fluorescent lamp or wireless telephone; remote controller should be close to indoor unit during operation.
- Replace new batteries of the same model when replacement is required.
- When you don't use remote controller for a long time, please take out the batteries.
- If the display on remote controller is fuzzy or there's no display, please replace batteries.

## Buttons on remote controller(YBE1FB1F)



### Introduction for buttons on remote controller

#### NOTE:

- This is a general use remote controller. It could be used for the air conditioner with multifunction. For the functions which the model doesn't have, if press the corresponding button on the remote controller, the unit will keep the original running status.
- After putting through the power, the air conditioner will give out a sound. Power indicator "⏻" is ON. After that, you can operate the air conditioner by using remote controller.
- Under on status, pressing the button on the remote controller, the signal icon "📶" on the display of remote controller will blink once and the air conditioner will give out a "di" sound, which means the signal has been sent to the air conditioner.
- As for the models with functions of WiFi or wired controller, the indoor unit must has been controlled by standard remote controller under auto mode first, and then the function of adjustable temperature under auto mode can be realized by APP or the wired controller.
- This remote controller can adjust the temperature under auto mode. When matching with the unit which is without the function of adjustable temperature under auto mode, the set temperature under auto mode may be invalid, or the displayed set temperature on the unit is not same as that on the remote controller under auto mode.



On/Off button

Press this button to turn on the unit. Press this button again to turn off the unit.

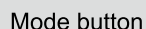

Mode button

Press this button to select your required operation mode.

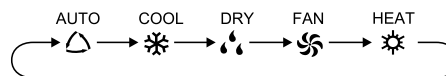

- When selecting auto mode, air conditioner will operate automatically according to the sensed temperature. Press "Fan" button can adjust fan speed. Press "🌀" / "🌀" button can adjust fan blowing angle.
- After selecting cool mode, air conditioner will operate under cool mode. Press "+" or "-" button to adjust set temperature. Press "Fan" button to adjust fan speed. Press "🌀" / "🌀" button to adjust fan blowing angle.
- When selecting dry mode, the air conditioner operates at low speed under dry mode. Under dry mode, fan speed can't be adjusted. Press "🌀" / "🌀" button to adjust fan blowing angle.
- When selecting fan mode, the air conditioner will only blow fan, no cooling and no heating. Press "Fan" button to adjust fan speed. Press "🌀" / "🌀" button to adjust fan blowing angle.
- When selecting heat mode, the air conditioner operates under heat mode. Press "+" or "-" button to adjust set temperature. Press "Fan" button to adjust fan speed. Press "🌀" / "🌀" button to adjust fan blowing angle.

#### NOTE:

### Introduction for icons on display screen

	Quiet	
	Set fan speed	
	Turbo mode	
	Send signal	
Operation mode		Auto mode
		Cool mode
		Dry mode
		Fan mode
		Heat mode
	X-FAN function	
	Humidity control	
	Power limiting operation	
	Set temperature	
	Indoor ambient temp.	
	Indoor ambient humidity	
ON OFF	TIMER ON / TIMER OFF	
	Set time	
	Left & right swing	
	Up & down swing	
	Child lock	
	Fast cool	
	Health and UVC functions	
	WiFi function	
	LED	
	Auto LED	
	I feel	
	Sleep mode	
	Two-way ventilation function	

- For preventing cold air, after starting up heat mode, indoor unit will delay 1~5 minutes to blow air (Actual delay time depends on indoor ambient temperature).
- Set temperature range from remote controller: 16 ~ 30°C (61-86°F). Set temperature range from remote controller under HEAT mode: 8~30°C (46-86°F).
- Under auto mode, temperature can be displayed; and set temperature can be adjusted.

This mode indicator is not available for some models.

#### Fan button

This button is used for setting Fan Speed in the sequence that goes from AUTO, , , , , , to , then back to Auto.

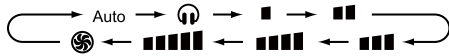

- Low speed ■■ Low-Medium speed ■■■ Medium speed
- Medium-High speed ■■■■■ High speed
- Turbo speed Quiet speed

#### NOTE:

- Under AUTO speed, air conditioner will select proper fan speed automatically according to factory default setting.
- It's low fan speed under dry mode.
- X-FAN function: Hold fan speed button for 2s in cool or dry mode, the icon " " is displayed and the indoor fan will continue operation for a few minutes in order to dry the indoor unit even though you have turned off the unit. After energization, X-FAN OFF is defaulted. X-FAN is not available in auto, fan or heat mode.

This function indicates that moisture on evaporator of indoor unit will be blown after the unit is stopped to avoid mould.

- Having set X-FAN function on: After turning off the unit by pressing " On/Off " button indoor fan will continue running for a few minutes. at low speed. In this period, hold fan speed button for 2s to stop indoor fan directly.
- Having set X-FAN function off: After turning off the unit by pressing " On/Off " button, the complete unit will be off directly.

#### + / - button

Press " + " or " - " button once increase or decrease set temperature 1°C(°F). Holding " + " or " - " button, 2s later, set temperature on remote controller will change quickly. On releasing button after setting is finished, temperature indicator on indoor unit will change accordingly.

#### Wifi button

Press "Wifi" button to turn on WiFi function, "Wifi" icon will be displayed on the remote controller;  
Hold "Wifi" button for 5s to turn off WiFi function and "Wifi" icon will disappear.

Under off status, press "Mode" and "Wifi" buttons simultaneously for 1s, WiFi module will restore factory settings.

#### NOTE:

- This function is only available for some models.

#### I Feel button

Press this button to start I Feel function and " " will be displayed on the remote controller. After this function is set, the remote controller will send the detected ambient temperature to the controller and the unit will automatically adjust the indoor temperature according to the detected temperature. Press this button again to close I Feel function and " " will disappear. Please put the remote controller near user when this function is set. Do not put the remote controller near the object of high temperature or low temperature in order to avoid detecting inaccurate ambient temperature. When I Feel function is turned on, the remote controller should be put within the area where indoor unit can receive the signal sent by the remote controller.

#### UD-swing button

Press this button can select up & down swing angle. Fan blow angle can be selected circularly as below:

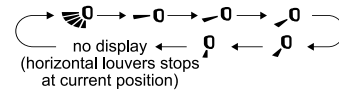

- When selecting " ", air conditioner is blowing fan automatically. Horizontal louver will automatically swing up & down at maximum angle.
- When selecting " ", a air conditioner is blowing fan at fixed position. Horizontal louver will stop at the fixed position.
- Hold " " button above 2s to set your required swing angle. When reaching your required angle, release the button.

#### NOTE:

- Press this button continuously more than 2s, the main unit will swing back and forth from up to down, and then loosen the button, the unit will stop swinging and present position of guide louver will be kept immediately.
- Under swing up and down mode, when the status is switched from off to , if press this button again 2s later, status will switch to off status directly; if press this button again within 2s, the change of swing status will also depend on the circulation sequence stated above.

#### Humidity button

Under cooling mode, press this button can select humidity control with cooling mode, smart dehumidification with cooling mode, and general cooling mode, and they can be set to operate circularly.

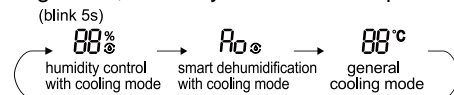

- When humidity control with cooling mode is set, the remote controller will display " " , and humidity value "88" and "%" icon will blink for 5s; you can press "+" and "-" buttons to set the humidity value within 5s.  
Under humidity control with cooling mode, humidity setting range for the remote controller: 40%-80%.  
Temperature can be adjusted under humidity control with cooling mode.
- When smart dehumidification with cooling mode is set, the remote controller will display " " ; the remote controller and indoor unit will display "Ao" for 5 seconds.

Temperature can be adjusted under smart dehumidification with cooling mode.

- The humidity for smart dehumidification is automatically adjusted according to human body comfort; no need to set the humidity manually.

Under dry mode, press this button can select humidity control with dehumidification mode, continuous dehumidification mode, general dehumidification mode, and they can be set to operate circularly.



- When humidity control with dehumidification mode is set, the remote controller will display "☉", "%" and humidity value "88"; you can press "+" and "-" buttons to set the humidity value.

Humidity setting range for the remote controller: 30%-70%.

Temperature can't be adjusted under humidity control with dehumidification mode.

- When continuous dehumidification is set, the remote controller will display "☉"; the remote controller and indoor unit will display "Co".

Temperature can't be adjusted under continuous dehumidification mode.

- Under continuous dehumidification mode, the unit always works under dehumidification status; no need to set temperature and humidity.

**NOTE:**

- The air conditioner is mainly used for controlling the temperature, while the humidity control is the auxiliary function. The humidity will be affected by the factors such as indoor and outdoor environment, degree of indoor sealing and indoor flow.
- When the set humidity is higher than current atmospheric humidity, the set humidity can't be reached.
- If the humidity sensor is with malfunction, humidity setting under cooling mode or dehumidification mode will stop and the unit operates under general cooling mode or dehumidification mode.

LR-swing button

Press this button can select left & right swing angle. Fan blow angle can be selected circularly as below:

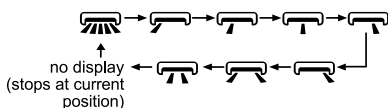

**NOTE:**

- Press this button continuously more than 2s, the main unit will swing back and forth from left to right, and then loosen the button, the unit will stop swinging and present position of guide louver will be kept immediately.
- Under swing left and right mode, when the status is switched from off to , if press this button again 2s later, status will switch to off status directly; if press this button again within 2s, the change of swing status will also depend on the circulation sequence stated above.
- This function only applicable for some models.

Timer button

- At ON status, press this button once can set TIMER OFF. The character of HOUR and OFF will flash. Press "+" or "-" button within 5s can adjust the time of TIMER OFF. After each pressing of "+" or "-" button, time will increase or decrease half an hour. When holding "+" or "-" button, 2s later, the time will change quickly until to reach to your required time. After that, press "Timer" button to confirm it. The character of HOUR and OFF won't flash again.

Cancel TIMER OFF: Press "Timer" button again under TIMER OFF status.

- At OFF status, press this button once can set TIMER ON. Please refer to TIMER off for detailed operation.

Cancel TIMER ON: Press "Timer" button again under TIMER ON status.

**NOTE:**

- Time setting range: 0.5-24 hours.
- Time interval between two operations can't exceed 5s. Otherwise, remote controller will exit the setting status automatically.

Sleep button

Press this button, can select Sleep 1 (☉), Sleep 2 (☉), Sleep 3 (☉) and cancel the Sleep, circulate between these, after electrified, Sleep Cancel is defaulted.

- Sleep 1 is Sleep mode 1, in Cool modes: sleep status after run for one hour, the main unit setting temperature will increase 1, two hours, setting temperature increased 2, then the unit will run at this setting temperature; In Heat mode: sleep status after run for one hour, the setting temperature will decrease 1, two hours, setting temperature will decrease 2, then the unit will run at this setting temperature.

- Sleep 2 is sleep mode 2, that is air conditioner will run according to the presetting a group of sleep temperature curve.

- Sleep 3 the sleep curve setting under Sleep mode by DIY;

(1) Under Sleep 3 mode, press "Health" button for a long time, remote controller enters into user individuation sleep setting status, at this time, the time of remote controller will display "1HOUR", the setting temperature "88" will display the corresponding temperature of last setting sleep curve and blink (The first entering will display according to the initial curve setting value of original factory);

(2) Adjust " + " and " - " button, could change the corresponding setting temperature, after adjusted, press "Health" button for confirmation;

(3) At this time, 1hour will be automatically increased at the timer position on the remote control, (that are "2HOUR" or "3HOUR" or "8HOUR"), the place of setting temperature "88" will display the corresponding temperature of last setting sleep curve and blink;

(4) Repeat the above step (2)~(3) operation, until 8 hours temperature setting finished, sleep,curve setting finished, at this time, the remote controller will resume the original timer display; temperature display will resume to original setting temperature.

- Sleep 3 the sleep curve setting under Sleep mode by DIY could be inquired:

The user could accord to sleep curve setting method to inquire the presetting sleep curve, enter into user individuation sleep setting status, but do not change the temperature, press "Health" button directly for confirmation. Note: In the above presetting or enquiry procedure, if continuously within 10s, there is no button pressed, the sleep curve setting within 10s, there is no button pressed, the

sleep curve setting status will be automatically quit and resume to display the original displaying. In the presetting or enquiry procedure, press " On/Off " button, "Mode" button, "Timer" button or "Sleep" button, the sleep curve setting or enquiry status will quit similarly.

#### Light button

Press this button to control the LED status on the displayer, the circulation change is as follow:

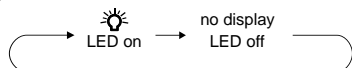

### Function introduction for combination buttons

#### Energy-saving function

Under cooling mode, press "Mode" and "Timer" buttons simultaneously to start up or turn off energy-saving function. When energy-saving function is started up, "SE" will be shown on remote controller, and air conditioner will adjust the set temperature automatically according to ex-factory setting to reach to the best energy-saving effect.

Press "Mode" and "Timer" buttons simultaneously again to exit energy-saving function.

#### NOTE:

- Under energy-saving function, fan speed is defaulted at auto speed and it can't be adjusted.
- Under energy-saving function, set temperature can't be adjusted.
- Sleep function and energy-saving function can't operate at the same time. If energy-saving function has been set under cool mode, press "Sleep" button will cancel energy-saving function. If sleep function has been set under cool mode, start up the energy-saving function will cancel sleep function.

#### Child lock function

Hold " On/Off " and " - " buttons simultaneously for 3s to turn on or turn off child lock function. When child lock function is on, "🔒" icon is displayed on remote controller. If you operate the remote controller, the "🔒" icon will blink three times without sending signal to the unit.

#### Temperature display switchover function

Under OFF status, hold "Mode" and " - " buttons simultaneously for 3s to switch temperature display between °C and °F.

#### Indoor ambient temperature or humidity display

By holding " On/Off " and " 🏠 " buttons simultaneously, you can see indoor ambient temperature or indoor ambient humidity on indoor unit's display. The setting on remote controller is selected circularly as below:



- When selecting " 🏠 " with remote controller, temperature indicator on indoor unit displays indoor ambient temperature.
- When selecting " 🏠 " with remote controller, temperature indicator on indoor unit displays indoor ambient humidity.

#### NOTE:

- The ambient humidity value is only for reference. Eg: If humidity value is "0%", there may be malfunction for the humidity detection board. Please contact local service provider.
- There may be some measuring deviation for humidity detection and photosensitiveness detection.

#### Clean reminder function of filter

The reminder function is defaulted to be OFF. Hold " On/Off " and " 🗨 " buttons simultaneously for 5s to turn it on. The buzzer will give out sound for 0.5s and the dual-8 nixie tube on the display will be on for 3s; Once the reminder function is turned on, when the air conditioner has reached to the set time, the dual-8 nixie tube will flash about 30s when the unit is turned on each time to remind the user to clean the filter; you can turn off this cycle reminder by holding " On/Off " and " 🗨 " buttons simultaneously for 5s and then the air conditioner will count time again.

#### NOTE:

- Once the reminder function is turned on, only this cycle reminder can be cleared.
- This function is only available for some models.

#### Fast cool function

Press " On/Off " and " + " buttons simultaneously under cooling mode can select 25°C(77°F) fast cooling mode, 16°C(61°F) fast cooling mode and normal cooling mode circularly. "⊗" icon will be displayed on the remote controller under fast cooling mode.

Once it enters into fast cooling mode, the fan speed is auto fan and the set temperature is 25°C(77°F) or 16°C(61°F). At this time, the set temperature flashes to display for 5s. In the flashing period, press " + " or " - " button to adjust the set temperature.

Press "Fan" button to adjust the fan speed. If the set temperature and the fan speed haven't been adjusted during that time, the remote controller and the indoor unit will operate under current set temperature and fan speed for 20 minutes. 20 minutes later, the set temperature and the fan speed for the remote controller and the indoor unit will turn to the status before quick cooling.

#### NOTE:

- If the set temperature and the fan speed have been adjusted during the operation under fast cooling mode, the unit will exit from the fast cooling mode. Then the indoor unit operates continuously under the adjusted status.
- Fast cooling function is only applicable for some models. If this function is unavailable for this indoor unit, 20 minutes later, the remote controller will turn back to the status before fast cooling. Indoor unit operates continuously according to current status. At this time, status of indoor unit and the display status on the remote controller may be different.
- This function is only available for some models.

#### Auto clean function

Under unit off status, hold "Mode" and " 🗨 " buttons

simultaneously for 5s to turn on or turn off the auto clean function. When the auto clean function is turned on, indoor unit displays "CL". During the auto clean process of evaporator, the unit will perform fast cooling or fast heating. There may be some noise, which is the sound of flowing liquid or thermal expansion or cold shrinkage. The air conditioner may blow cool or warm air, which is a normal phenomenon. During cleaning process, please make sure the room is well ventilated to avoid affecting the comfort.

**NOTE:**

- The auto clean function can only work under normal ambient temperature. If the room is dusty, clean it once a month; if not, clean it once every three months. After the auto clean function is turned on, you can leave the room. When auto clean is finished, the air conditioner will enter standby status.
- This function is only available for some models.

Night mode

Under cooling or heating mode, when turning on sleep mode and turn to low speed or quiet notch, the outdoor unit would enter into night mode.

**NOTE:**

- When you feel that the cooling and heating effect is poor, please press "Fan" button to other fan speed or press "Sleep" button to exit the night mode.
- The night mode can only work under normal ambient temperature.
- This function is only available for some models.

### Replacement of batteries in remote controller

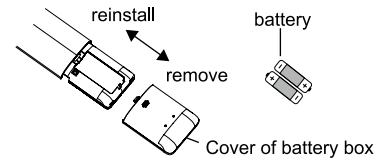

1. Press the back side of remote controller marked with "⊞", as shown in the fig, and then push out the cover of battery box along the arrow direction.
2. Replace two 7# (AAA 1.5V) dry batteries, and make sure the position of "+" polar and "-" polar are correct.
3. Reinstall the cover of battery box.

**NOTICE:**

- During operation, point the remote control signal sender at the receiving window on indoor unit.
- The distance between signal sender and receiving window should be no more than 8m, and there should be no obstacles between them.
- Signal may be interfered easily in the room where there is fluorescent lamp or wireless telephone; remote controller should be close to indoor unit during operation.
- Replace new batteries of the same model when replacement is required.
- When you don't use remote controller for a long time, please take out the batteries.
- If the display on remote controller is fuzzy or there's no display, please replace batteries.

## 6.2 GREE+ App Operation Manual

### Control Flow Chart

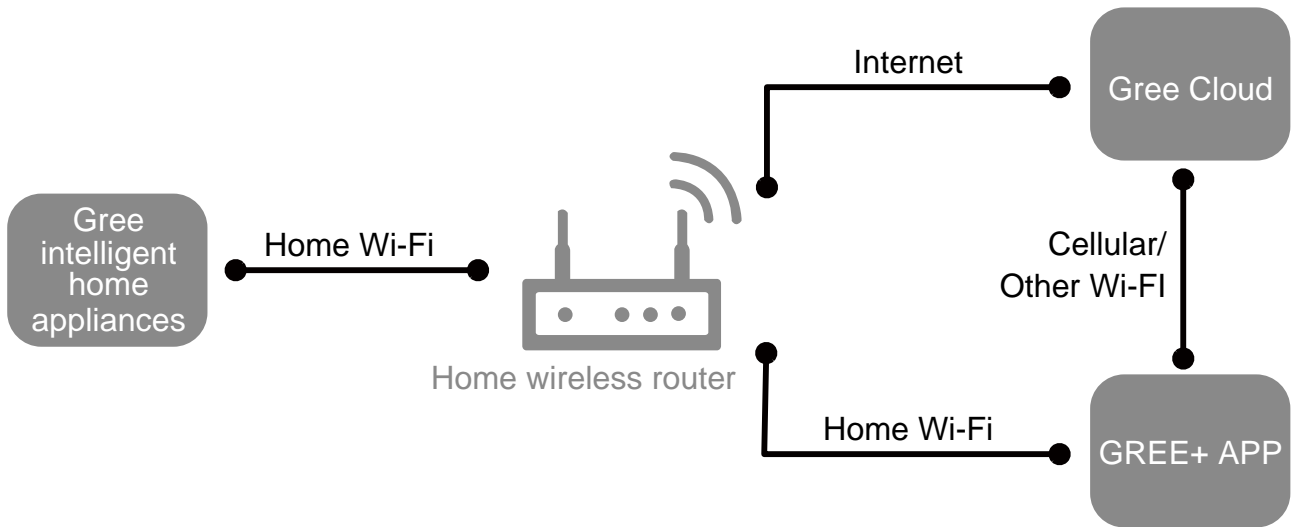

### Operating Systems

Requirement for User's smart phone:



iOS system  
Support iOS7.0 and  
above version



Android system  
Support Android 4.4 and  
above version

### Download and installation



GREE+ App Download Linkage

Scan the QR code or search "GREE+" in the application market to download and install it. When "GREE+" App is installed, register the account and add the device to achieve long-distance control and LAN control of Gree smart home appliances. For more information, please refer to "Help" in App.

## 6.3 Ewpe Smart App Operation Manual

### Control Flow Chart

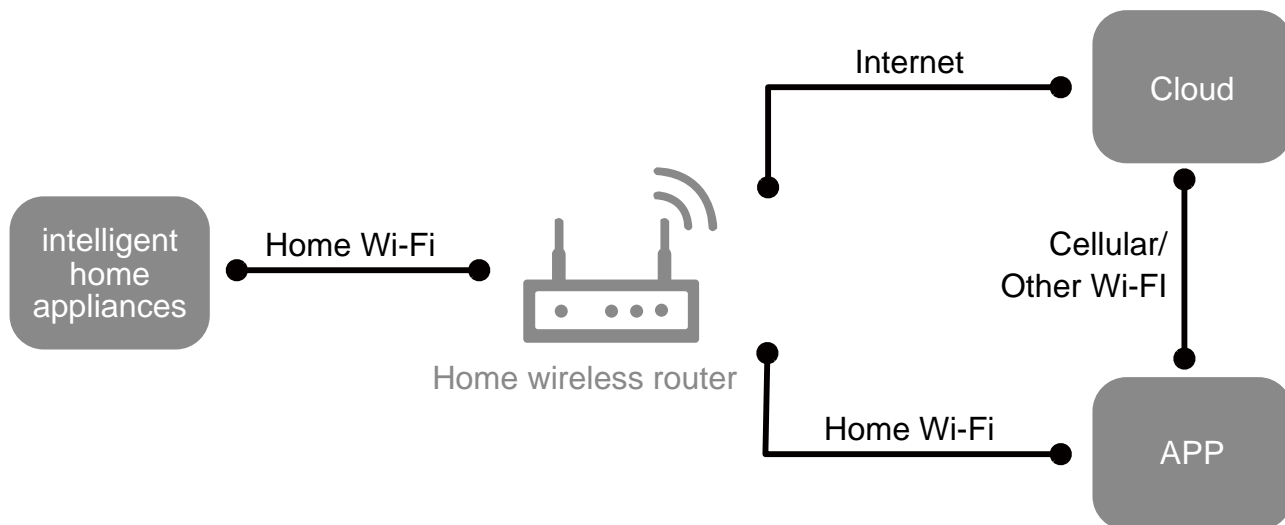

### Operating Systems

Requirement for User's smart phone:



iOS system  
Support iOS7.0 and  
above version



Android system  
Support Android 4.4 and  
above version

### Download and installation



App Download Linkage

Scan the QR code or search "Ewpe Smart" in the application market to download and install it. When "Ewpe Smart" App is installed, register the account and add the device to achieve long-distance control and LAN control of smart home appliances.

For more information, please refer to "Help" in App.



## 6.4 Brief Description of Models and Functions

### I. Main Functions

#### 1.1 Temperature Control

##### Definitions of Temperatures:

The definitions of temperatures are classified as following.

- Room temperature: temperature of lower part of the room
- Set temperature: temperature set by remote controller
- Room thermistor temperature: temperature detected by room temperature thermistor
- Target temperature: temperature determined by microcomputer

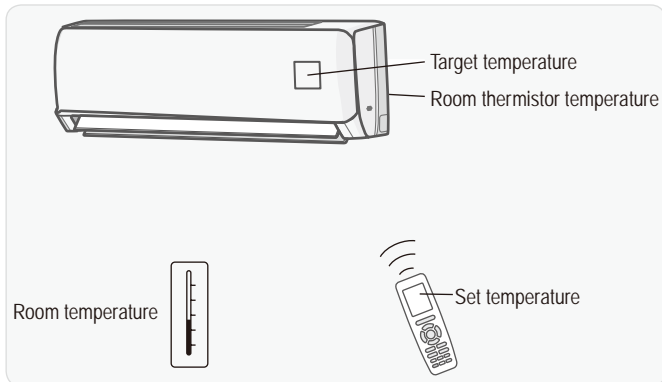

##### Temperature Control:

The temperature of the room is detected by the room temperature thermistor. However, there is a difference between the temperature detected by room temperature thermistor and the temperature of lower part of the room, depending on the type of the indoor unit or installation condition. Practically, the temperature control is done by the target temperature appropriately adjusted for the indoor unit and the temperature detected by room temperature thermistor.

##### Ambient temperature display function:

When the set temperature is set to be displayed by the remote controller, indoor unit displays current set temperature. When the remote control signal is switched to indoor ambient temperature display status from other display status, indoor ambient temperature will be displayed for 3s.

##### I Feel mode:

In order to make room thermistor temperature almost same as the actual operation environment temperature, I Feel mode is designed. After I Feel mode is turned on, the remote controller will send the ambient temperature to the controller of indoor unit intermittently and constantly adjusts the calculated target temperature to make the operation of the air conditioner more suitable for users' needs.

#### 1.2 Frequency Principle

##### Control Parameters:

The frequency of the compressor is controlled by the following 2 parameters:

- The load condition of the operating indoor unit
- The difference between the room thermistor temperature and the target temperature

The target frequency is adapted by additional parameters in the following cases:

- Frequency restrictions
- Initial settings

##### Inverter Features:

The inverter provides the following features:

- The regulating capacity can be changed according to the changes in the outdoor temperature and cooling/heating load.

##### ● Quick heating and quick cooling

The rotation speed of the compressor is increased when starting the heating (or cooling).

This enables to reach the set temperature quickly.

- Even during extreme cold weather, high capacity is achieved.

##### ● Comfortable air conditioning

A fine adjustment is integrated to keep the room temperature constant.

##### ● Energy saving heating and cooling

Once the set temperature is reached, the energy saving operation enables to maintain the room temperature at low power.

##### Frequency Limits:

The following functions regulate the maximum frequency:

- Discharge pipe temperature control. Refer to 3.4.
- Input current control. Refer to 3.5.
- Freeze-up protection control. Refer to 3.6
- Heating peak-cut control. Refer to 3.7

#### 1.3 Airflow Direction Control

##### Power-Airflow Flap:

The flap sends a large volume of air downward to the floor and provides an optimum control in cooling, dry, and heating operation.

##### Cooling/Dry

During cooling or dry operation, the flap directs airflow horizontal. Then, cool air can be blown far and distributed all over the room.

##### Heating

During heating operation, the flap directs airflow downward to spread the warm air to the entire room.

##### Wide-Angle Louvers:

The louvers, made of synthetic resin, provide a wide range of airflow that guarantees comfortable air distribution.

##### Auto swing angle range:

After setting auto swing function, the air guide louver automatically swing among L1-A1-B1-C1-D under cooling mode. Under heating mode, the air louver automatically swing among L-A-B-C-D. As for different unit, the angle value is different for L1, A1, B1, C1, D1, L, A, B, C and D.

##### COMFORT AIRFLOW Operation:

The flaps are controlled not to blow the air directly at the people in the room.

The airflow will be in the upward direction while in cooling operation and in the downward direction while in heating operation, which will provide a comfortable wind that will not come in direct contact with people.

When heating mode is just started up, the air guide louver will swing to the position where the cold air won't blow to the people for cold air prevention. When entering into defrosting stage, the air guide louver will also swing to the position where the cold air won't blow to the people.

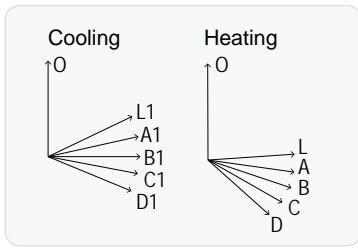

## 1.4 Fan Speed Control for Indoor Unit

### Fan:

Indoor fan operates at the fan speed set by the remote controller.

### AUTO:

The fan speed is regulated according to the indoor heat exchanger temperature and the difference between the room thermistor temperature and the target temperature. When the set temperature is quite different from the room temperature, it indicates there is high demand for cooling and heating. Indoor fan will operate at the high fan speed. When temperature difference between the set temperature and the room temperature is not big, it indicates there is medium demand for cooling and heating. Indoor fan will operate at the medium fan speed. When temperature difference between the set temperature and the room temperature is small, it indicates there is small demand for cooling and heating. Indoor fan will operate at the low fan speed.

## 1.5 Program Dry Operation

Program dry operation removes humidity while preventing the room temperature from lowering. Since the microcomputer controls both the temperature and airflow rate, the temperature adjustment and FAN setting buttons are inoperable.

## 1.6 X-fan Function

When the unit is under cooling or dry mode, the X-fan function can be turned on by pressing the "X-fan" button on the remote controller (if there is X-fan button on the remote controller). If X-fan function is turned, when the unit is turned off by the remote controller, the indoor fan will still operate for several minutes at the low fan speed. When the unit is operating under X-fan mode, the complete unit will be turned off immediately if use the remote controller to turn off the X-fan function.

## 1.7 Automatic Operation

### Automatic Cooling/Heating Function

When the automatic operation is selected with the remote controller, the microcomputer automatically determines the operation mode as cooling or heating according to the room temperature and the set temperature at start-up.

The unit automatically switches the operation mode to maintain the room temperature at the set temperature.

## 1.8. NIGHT SET Mode

Some models are only with good sleep mode.

NIGHT SET Mode continues operation at the target temperature for the first one hour, then automatically raises the target temperature slightly in the case of cooling, or lowers it slightly in the case of heating. This prevents excessive cooling in summer and excessive heating in winter to ensure comfortable sleeping conditions, and also conserves electricity.

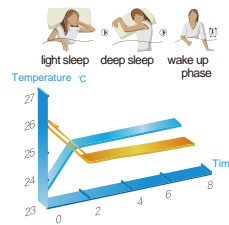

### • Sound sleep mode

set temperature is close to body temperature and will adjust automatically and intelligently.

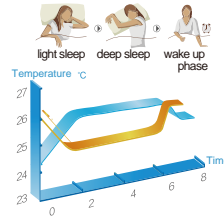

### • Good sleep mode

before you get up, set temperature will decrease or increase automatically to refresh you in the morning.

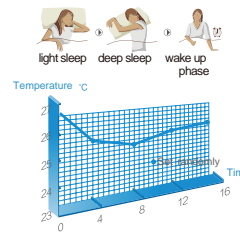

### • DIY mode

you can set temperature curve and sleep time as you like.

## 1.9 ECONO Operation

ECONO operation reduces the maximum operating current and the power consumption.

This operation is particularly convenient for energy-saving. It is also a major bonus when breaker capacity does not allow the use of multiple electrical devices and air conditioners. This function can be set only in cooling mode.

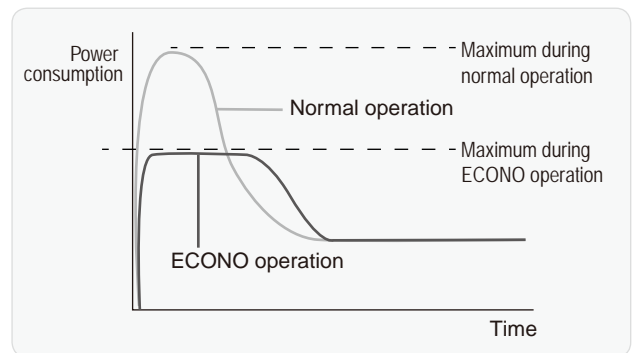

## 1.10 Timer Function

The timing function of the complete unit is divided into general timer and clock timer, which can be switched by equipping different remote controls.

### 1. General timer function:

#### Timer ON function:

Timer ON time can be set under unit off status (power is put through) through the remote control. Timer setting range is 0.5 ~ 24h in 30min increments.

#### Timer OFF function:

Timer OFF time can be set under unit on status through the remote control. Timer setting range is 0.5 ~ 24h in 30min increments.

### 2. Clock timer function

Unit on or unit off at a certain time can be set through the remote

control with the precision of 1min.

#### **Timer ON function:**

Timer ON time can be set under unit off status (power is put through) through the remote control. When the set timer ON time is reached, the unit will start to run according to previous setting mode. If timer ON is set during operation of the unit, the unit will continue to operate.

#### **Timer OFF function:**

Timer OFF time can be set under unit on status through the remote control. When the set timer OFF time is reached, the unit will stop operation. If timer OFF is set under unit off status, the system will keep standby status.

### **1.11 Refrigerant Recycling Function**

Under cooling mode, the unit will enter the refrigerant recycling mode after receiving the command set by the remote control, and the compressor will run at high frequency for refrigerant recycling.

**Control measure:** within 5min of energizing, turning on the unit in cooling mode with set temperature of 16°C, continuously press light button for 3 times within 3s to enter refrigerant recycling mode. Fo will be displayed and refrigerant recycling mode will be sent to the outdoor unit.

### **1.12 8°C Heating Mode**

Under heating mode, the set temperature is 8°C and indoor display board displays the set temperature 8°C (according to the "8" pattern displayed in the lower position and not displayed in the higher position). 46 is displayed in Fahrenheit temperature and the unit is in heating operation.

**Control measures:** according to the difference between the set temperature and the ambient temperature, the indoor fan chooses to run at different speeds.

1) When the compressor is running, the fan speed is adjusted according to the following automatic speed mode.

When  $(T_{amb.} - \Delta T_{supplementary}) \leq (T_{set} - 2^{\circ}C)$ , the indoor fan runs at high speed;

When  $(T_{set} - 2^{\circ}C) < (T_{amb.} - \Delta T_{supplementary}) < T_{set}$ , the indoor fan runs at medium speed;

When  $(T_{amb.} - \Delta T_{supplementary}) \geq T_{set}$ , the indoor fan runs at low speed;

2) High speed, medium speed and low speed are switched, and a minimum running time of 3 minutes and 30 seconds must be ensured.

### **1.13 Comfortable Energy-saving Mode**

Under cooling mode, when the comfortable energy-saving command is received from the remote control, the controller enters the comfortable energy-saving mode; the indoor unit executes set temperature of 27°C, and the horizontal louver turns to the angle that can blow cold air directly to the human body.

**Control measures:** under this mode, when the compressor is running, the fan speed is adjusted according to the automatic fan speed mode under the condition of energy-saving mode (see below); when the compressor stops, the indoor fan runs at a low speed.

1) When the compressor is running, the fan speed is adjusted according to the following automatic speed mode.

When  $(T_{amb.} - \Delta T_{supplementary}) \leq (T_{set} - 2^{\circ}C)$ , the indoor fan runs at low speed;

When  $(T_{set} - 2^{\circ}C) < (T_{amb.} - \Delta T_{supplementary}) < T_{set}$ , the indoor fan runs at

medium speed;

When  $(T_{amb.} - \Delta T_{supplementary}) \geq T_{set}$ , the indoor fan runs at high speed; 2) High speed, medium speed and low speed are switched, and a minimum running time of 3 minutes and 30 seconds must be ensured.

### **1.14 Mild Dry Function**

For the air conditioner with this function, if the indoor unit receives the normal humidity value sent by WiFi (not 0), the "Mild Dry" sign and humidity value will be sent to the outdoor unit; if the indoor unit doesn't receive the humidity value of the WiFi board, the "Without Mild Dry" sign will be sent to the outdoor unit;

After energization, as long as the normal humidity value sent by WiFi (not 0) is received, it is considered that there is a humidity sensor;

If the humidity sensor error or the WiFi communication error sent by the WiFi detection board is received and there is a humidity sensor, the humidity sensor error sign will be sent to the outdoor unit;

### **1.15 New Access Control Function**

(1) **Switch control function:** customers are required to install the dry contact and wire controller by themselves to detect whether there is anyone in the room through the dry contact. If there is anyone (detection signal is high level), it will be handled according to the last remote control or timer. If there is no one (detection signal is low level), it will keep shutdown or shut down after operating for 6 minutes;

(2) **Switch control function:** customers are required to install the dry contact and wire controller by themselves to detect whether there is anyone in the room through the dry contact. If there is anyone (detection signal is high level), it will be handled according to the last remote control or timer. If there is no one (detection signal is low level), it will keep shutdown or shut down after operating for 6 minutes;

### **1.16 FastCool Function**

Under cooling mode, when the FastCool command sent by the remote control is received, the controller enters the FastCool mode, and starts 20min timing. The running status is according to the remote control command. After 20 minutes, the temperature and fan speed will return to the cooling state before entering FastCool (if the cooling mode has not been run before entering FastCool after energization, it will run according to the automatic fan mode of 25°C); if the unit has ever been controlled by the APP, wired controller or auto button, FastCool mode will be exited.

### **1.17 Other Functions**

#### **1.17.1 Auto clean function**

When the remote control is under unit off status, holding the MODE button and FAN button for 5 seconds at the same time, the remote control displays "CL", and the unit enters the auto clean mode.

The auto clean function of the indoor unit includes preparation stage, condensing stage, frosting stage, defrosting and sterilization stage.

If the outer unit has auto clean function, the outdoor unit will enter the auto clean function after cleaning of indoor unit is completed. The auto clean function of outdoor unit includes condensing stage, frosting stage, defrosting and deducting stage. If the outdoor unit

doesn't have auto clean function, the indoor fan will exit the "auto clean" mode directly and operates according to the remote control setting.

Note: Auto clean function will be entered at a certain ambient temperature. For the heat pump models, auto clean of the indoor unit includes high-temperature sterilization stage. For cooling only models, there is no such sterilization stage.

### 1.17.2 Auto preheating function

Under standby status, after the compressor stops for 10 minutes, if  $T_{\text{outdoor amb.}} \leq -5^{\circ}\text{C}$  and  $T_{\text{discharge}} \leq -5^{\circ}\text{C}$ , the compressor coil starts preheating.

During the coil preheating period, if  $T_{\text{discharge}} > 0^{\circ}\text{C}$ , the compressor stops preheating. After the compressor stops preheating, if  $T_{\text{discharge}} \leq -5^{\circ}\text{C}$  and the outdoor ambient temperature meets the conditions for the compressor coil auto preheating control, it will enter the compressor coil auto preheating control again.

### 1.17.3 Buzzer

When the controller is energized or receives remote control signal, auto button and other valid control signals, the buzzer will give out a beep.

If the weak tone signal of buzzer is set by the remote control, the buzzer will give out weak tone. If the normal tone signal of buzzer is set by the remote control, the buzzer will give out normal tone.

### 1.17.4 Auto button

If this button is pressed under unit off status, the complete unit will operate in auto mode and IDU fan will operate at auto speed and swing function will be turned on. If this button is pressed under unit on status, the unit will be turned off.

### 1.17.5 Memory function

If a power failure (including one for just a moment) occurs during the operation, the operation restarts automatically when the power is restored in the same condition as before the power failure.

## 2. Thermistor Functions

### 2.1 Outdoor Heat Exchanger Thermistor

In cooling operation, the outdoor heat exchanger thermistor is used for high temperature protection.

In heating operation, the outdoor heat exchanger thermistor is used for Defrost Control

### 2.2 Discharge Pipe Thermistor

The discharge pipe thermistor is used for controlling discharge pipe temperature. If the discharge pipe temperature (used in place of the inner temperature of the compressor) rises abnormally, the operating frequency becomes lower.

The discharge pipe thermistor is used for detecting disconnection of the discharge pipe thermistor.

### 2.3 Indoor Heat Exchanger Thermistor

In cooling operation, the indoor heat exchanger thermistor is used for frozen-preventing protection high temperature protection.

In heating operation, the indoor heat exchanger thermistor is used for high temperature protection.

## 3. Control Specification

### 3.1 Frequency Control

#### Control Parameters

The frequency of the compressor is controlled by the following 2 parameters:

- 1 The load condition of the operating indoor unit
- 2 The difference between the room thermistor temperature and the target temperature

The target frequency is adapted by additional parameters in the following cases:

- Frequency restrictions
- Initial settings

#### Frequency limited

According to the building load, the outdoor ambient temperature determines the lower/upper limit of the frequency, and the frequency will also be limited according to the discharge temperature and the temperature value of the heat exchanger.

#### Inverter Features

The inverter provides the following features:

1. The regulating capacity can be changed according to the changes in the outdoor temperature and cooling/heating load.
  2. Quick heating and quick cooling
- The rotation speed of the compressor is increased when starting the heating (or cooling). This enables to reach the set temperature quickly.
3. Even during extreme cold weather, high capacity is achieved. It is maintained even when the outdoor temperature is  $2^{\circ}\text{C}$ .
  4. Comfortable air conditioning

A fine adjustment is integrated to keep the room temperature constant.

5. Energy saving heating and cooling

Once the set temperature is reached, the energy saving operation enables to maintain the room temperature at low power.

### 3.2 Power limiting operation

The function is for limiting power of the whole unit. Press "Mode" and "Sleep" buttons simultaneously, .The power is reduced to below 75% in low watt mode 1 and below 50% in low watt mode 2.

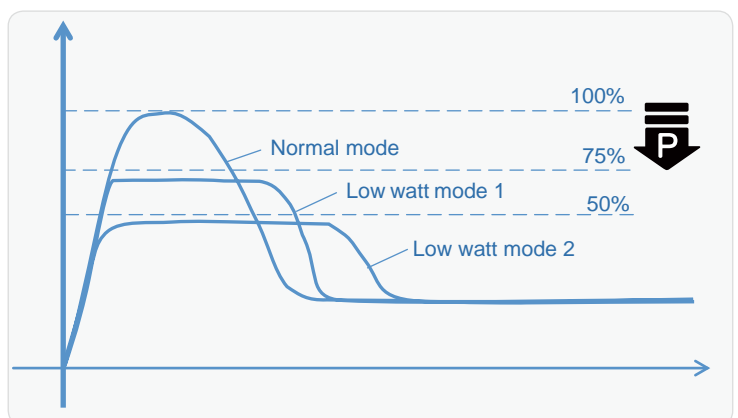

### 3.3 Mode Changing

#### 3.3.1 4-way valve control

The four way valve coil is energized/not energized depending on the operation (Heating: ON, Cooling/Dry/Defrost: OFF). In order to eliminate the switching sound as the four way valve coil switches

from ON to OFF when the heating is stopped, the OFF delay switch of the four way valve is carried out.

### 3.3.2 3-Minute Standby

Turning on the compressor is prohibited for 3 minutes after turning it off.

(The function is not activated when defrosting.)

### 3.3.3 Compressor protection function-stop point and stop time during frequency-increasing process

When turning the compressor from OFF to ON, there is stop point of frequency during the frequency-increasing process. It will stop for some at certain frequency. This stop time is determined by the system. (The function is not activated when defrosting.)

### 3.4 Discharge Pipe Temperature Control

The discharge pipe temperature is used as the internal temperature of the compressor. If the discharge pipe temperature rises above a certain level, the upper limit of frequency is set to keep the discharge pipe temperature from rising further.

### 3.5 Input Current Control

The microcomputer calculates the input current while the compressor is running, and sets the frequency upper limit based on the input current.

### 3.6 Evaporator frozen-preventing protection function

Whether decreasing frequency or not is determined by the temperature detected by the evaporator temperature sensor. If there is still frost after decreasing, the outdoor fan stops operation.

### 3.7 High Temperature Protection

Under cooling mode, the system is prevented from reaching abnormal high pressure by controlling the heat exchanger pipe temperature of the outdoor unit. Under heating mode, the system is prevented from reaching abnormal high pressure by controlling the heat exchanger pipe temperature of the indoor unit.

**Control measures:** Judge according to the temperature detected by the temperature sensor on the heat exchanger, and then control the frequency of the compressor.

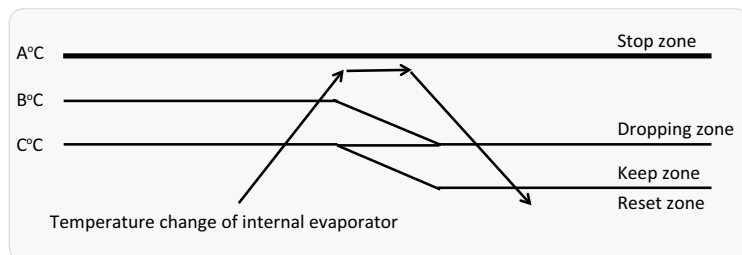

Outdoor unit temperature under cooling mode:

	A(°C)	B(°C)	C(°C)
9K	62	58	52
12K	66	62	59
18K cooling	64	61	58
18K heat pump	65	61	57
24K or above	68	64	62

Indoor unit's pipe temperature under heating mode:

	A(°C)	B(°C)	C(°C)
9K	62	56	50

12K	62	56	50
18K	62	57	52
24K or above	62	57	52

Zone	Control
Stop zone	When the temperature reaches the stop zone, the compressor stops.
Dropping zone	The upper limit of frequency decreases.
Keep zone	The upper limit of frequency is kept.
Reset zone	The upper limit of frequency is canceled.

### 3.8 Outdoor fan control

#### 3.8.1 Fan OFF control during defrosting

The outdoor fan is turned OFF during defrosting.

#### 3.8.2 Fan OFF delay when stopped

The outdoor fan is turned OFF 60 seconds after the compressor stops.

#### 3.8.3 The fan is started up before the compressor

The outdoor fan is turned on 20 seconds before the compressor starts.

#### 3.8.4 Outdoor fan speed control under low-temperature cooling mode

If the unit is with low-temperature cooling function, the speed of the outdoor fan is controlled to ensure that the evaporator is not defrosting during cooling operation with low outdoor temperature.

1. When the pipe temperature of outdoor unit is low, the rotation speed of the outdoor fan is reduced.

2. When the pipe temperature of outdoor unit is high, the rotation speed of the outdoor fan is controlled as well as normal operation.

#### 3.8.5. Fan speed control during indoor/outdoor unit quiet operation

The rotation speed of the outdoor fan is reduced by the command of the indoor/outdoor unit quiet operation.

#### 3.8.6. Fan ON/OFF control when operation (cooling, heating, dry) starts/stops

The outdoor fan is turned ON when the operation starts. The outdoor fan is turned OFF when the operation stops.

### 3.9 Cold Air Prevention Control

#### Outline

Under heating mode, in order to improve the user's comfort experience, prevent cold air blowing to the user when the evaporator temperature is not high.

#### Detail

Under heating mode, the position of the horizontal louver and the speed of the indoor unit are automatically adjusted according to the temperature of the indoor heat exchanger pipe:

(1) When the compressor starts or enters defrosting, the horizontal louver is adjusted to the first position. After the indoor heat exchanger pipe temperature rises, the horizontal louver is adjusted to the default position in heating or the set position.

(2) When the indoor ambient temperature and indoor heat exchanger pipe temperature are very low, the indoor fan does not operate, and the maximum time of non-operation is not more than 2 minutes. When the pipe temperature rises or the limit time of 2 minutes is reached, the indoor fan runs at a low speed, and the maximum time of low speed operation does not exceed 1 minute. When the pipe temperature continues to rise or the limit time of 1 minute is reached, the indoor fan runs at the set speed.

(3) When the indoor ambient temperature is high, but the indoor heat exchanger pipe temperature is low, the indoor fan runs at a low speed, and the maximum time of low speed operation is not more than 1 minute. When the pipe temperature rises or the limit time of 1 minute is reached, the indoor fan runs at the set speed.

### 3.10 Defrost Control

#### Outline:

Defrosting is carried out by the cooling cycle (reverse cycle). The defrosting time or outdoor heat exchanger temperature must be more than a certain value to finish defrosting.

#### Detail

##### Conditions for Starting Defrost

1. The starting conditions are determined with the outdoor temperature and the outdoor heat exchanger temperature.
2. The system is in heating operation.
3. The compressor operates for 10 minutes.
4. More than A minutes (depending on the duration of the previous defrost control) of accumulated time have passed since the start of the operation, or ending the previous defrosting.

##### Conditions for Canceling Defrost

The judgment is made with the outdoor heat exchanger temperature. (B°C)

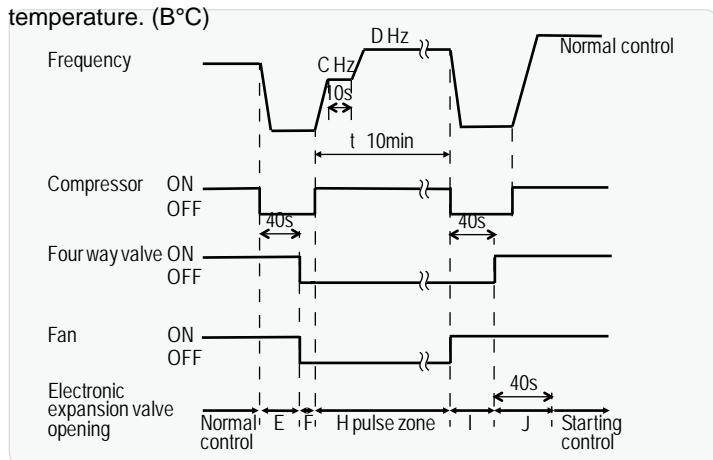

	9K	12K	18K	24K	30K\36K
A (minutes)	45	45	45	45	45
B (°C)	6~12	13~18	6~12	6~12	6~12
C (Hz)	60	60	60	60	60
D (Hz)	90	90	90	90	90
E (pulse)	480	480	480	480	480
F (pulse)	150	150	250	150	150
H (pulse)	250	280	300	250	250
I (pulse)	480	480	480	480	480
J (pulse)	250★	250★	300★	310★	320★

★ : Above data are different for different models.

### 3.11 Electronic Expansion Valve Control

#### Outline

The following items are included in the electronic expansion valve control.

##### Electronic expansion valve is fully opened

1. Electronic expansion valve is fully opened when turning off the power.
2. Pressure equalizing control.

##### Change Control

1. Electronic expansion valve control when starting operation.
2. Electronic expansion valve control when the frequency changes.
3. Electronic expansion valve control for defrosting
4. Electronic expansion valve control when the discharge pipe temperature is abnormally high.
5. Electronic expansion valve control when the air conditioner limits or decreases frequency.

#### Feedback Control

Target discharge pipe temperature control

##### 1. Changeing with Power ON

The electronic expansion valve is initialized when turning on the power. The opening position is set and the pressure is equalized.

##### 2. Pressure Equalizing Control

When the compressor is stopped, the pressure equalizing control is activated. The electronic expansion valve opens and the pressure is equalized.

##### 3. Opening Limit Control

The maximum and minimum opening of the electronic expansion valve are limited.

	pulse
Maximum opening	480
Minimum opening	50

The electronic expansion valve is fully opened when cooling operation stops, and is controlled at a fixed degree during defrosting.

##### 4. Starting Operation Control

The electronic expansion valve keeps initialized pulse 40s when the operation starts, thus preventing superheating or liquid compression.

##### 5. Control when the Frequency Changes

When the target discharge pipe temperature control is active, if the target frequency changes to a specified value in a certain time period, the target discharge pipe temperature control is canceled and the target opening of the electronic expansion valve is changed according to the frequency shift.

##### 6. High Discharge Pipe Temperature Control

When the compressor is operating, if the discharge pipe temperature exceeds a certain value, the electronic expansion valve opens and the refrigerant runs to the low pressure side. This procedure lowers the discharge pipe temperature.

##### 7. Frequency Limiting or Decreasing Control

When the system occurs frequency limiting or reduction for overcurrent, high temperature, overload and other reason, the opening degree of the electronic expansion valve is only allowed to increase but not allowed to decrease.

##### 8. Target Discharge Pipe Temperature Control

The target discharge pipe temperature is obtained from the indoor and outdoor environment temperature, and the electronic expansion valve opening is adjusted so that the actual discharge pipe temperature becomes close to the target discharge pipe temperature.

The electronic expansion valve opening and the target discharge pipe temperature are checked every 40 seconds.

### 3.12 Mainboard Module Overheating Protection

#### Outline

During operation, you can control the temperature of the mainboard module to prevent the mainboard from being damaged due to excessive temperature.

## Detail

According to the temperature and voltage output of the module on the mainboard, the temperature value is determined, and then the frequency of the compressor is controlled.

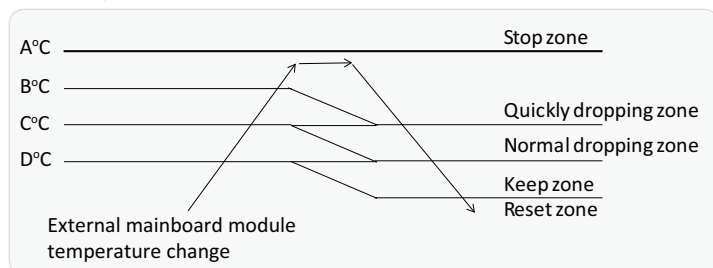

### Mainboard module overheating protection temperature:

	A(°C)	B(°C)	C(°C)	D(°C)
9K	100	96	93	90
12K	100	95	93	90
18K cooling	100	96	93	90
18K heat pump	95	93	90	87
24K and above	98	95	93	90

Zone	Control
Stop zone	When the temperature reaches the stop zone, the compressor stops.
Quickly dropping zone	The upper limit of frequency quickly decreases. until it drops to 44Hz or the lower limit.
Dropping zone	The upper limit of frequency decreases. until it drops to 44Hz or the lower limit.
Keep zone	The upper limit of frequency is kept.
Reset zone	The upper limit of frequency is canceled.

### Notice

If the unit stops for six consecutive times due to overheating protection of mainboard module, it cannot automatically resume operation, and ON/OFF shall be pressed to resume operation.

## 3.13 Refrigerant Lacking Protection

### Outline

In the initial stage of operation under cooling or dry mode, it will be judged according to the change of outdoor heat exchanger pipe temperature, the change of indoor heat exchanger pipe temperature and the difference between indoor heat exchanger pipe temperature and indoor ambient temperature, and the start and stop of the compressor is controlled to prevent the compressor from being damaged due to excessive temperature rise of the compressor motor.

### Detail

Under cooling or dry mode, when the compressor is operating, if the following conditions are met at the same time:

Outdoor heat exchanger pipe temperature change  $\leq 2^{\circ}\text{C}$

Indoor heat exchanger pipe temperature change  $\leq 2^{\circ}\text{C}$

The difference between the indoor heat exchanger pipe temperature and the indoor ambient temperature  $\leq 2^{\circ}\text{C}$

Compressor operating frequency  $\geq 30\text{Hz}$

It is determined that the system lacks refrigerant, and the complete unit is shut down for protection. If the unit stops for 3 consecutive times due to protection, the operation cannot be automatically resumed, and the indoor unit displays refrigerant lacking and valve blockage error code F0, which needs to be restored by re-energization.

## 3.14 Malfunctions

### 3.14.1 Sensor Malfunction Detection

Sensor malfunction can be detected in the following thermistors:

1. Outdoor heat exchanger thermistor
2. Discharge pipe thermistor
3. Outdoor temperature thermistor

When the temperature sensor error is detected, the complete unit will stop for protection.

### 3.14.2 Detection of Overcurrent and Overload

#### Outline

An excessive output current is detected and the overload temperature is observed to protect the compressor.

#### Detail

(1) If the overload (compressor head) temperature exceeds  $115^{\circ}\text{C}$ , the system shuts down the compressor.

(2) If the inverter current exceeds 10 ~ 22 A (depending on the model), the system shuts down the compressor.

# 7. Notes for Installation and Maintenance

## Safety Precautions: Important!

Please read the safety precautions carefully before installation and maintenance.

The following contents are very important for installation and maintenance.

**WARNING:** Installation Must be Performed in Accordance with the NEC/CEC by Authorized Personnel Only.

Please follow the instructions below.

- The installation or maintenance must accord with the instructions.
- Comply with all national electrical codes and local electrical codes.
- Pay attention to the warnings and cautions in this manual.
- All installation and maintenance shall be performed by distributor or qualified person.
- All electric work must be performed by a licensed technician according to local regulations and the instructions given in this manual.
- Be caution during installation and maintenance. Prohibit incorrect operation to prevent electric shock, casualty and other accidents.



## WARNINGS

### Electrical Safety Precautions:

1. Cut off the power supply of air conditioner before checking and maintenance.
2. The air condition must apply specialized circuit and prohibit share the same circuit with other appliances.
3. The air conditioner should be installed in suitable location and ensure the power plug is touchable.
4. Make sure each wiring terminal is connected firmly during installation and maintenance.
5. Have the unit adequately grounded. The grounding wire can't be used for other purposes.
6. Must apply protective accessories such as protective boards, cable-cross loop and wire clip.
7. The live wire, neutral wire and grounding wire of power supply must be corresponding to the live wire, neutral wire and grounding wire of the air conditioner.
8. The power supply cord and power connection wires can't be pressed by hard objects.
9. If power supply cord or connection wire is broken, it must be replaced by a qualified person.
10. If the power supply cord or connection wire is not long enough, please get the specialized power supply cord or connection wire from the manufacture or distributor. Prohibit

prolong the wire by yourself.

11. For the air conditioner without plug, an air switch must be installed in the circuit. The air switch should be all-pole parting and the contact parting distance should be more than 3mm.
12. Make sure all wires and pipes are connected properly and the valves are opened before energizing.
13. Check if there is electric leakage on the unit body. If yes, please eliminate the electric leakage.
14. Replace the fuse with a new one of the same specification if it is burnt down; dont replace it with a cooper wire or conducting wire.
15. If the unit is to be installed in a humid place, the circuit breaker must be installed.

### Installation Safety Precautions:

1. Select the installation location according to the requirement of this manual.(See the requirements in installation part)
2. Handle unit transportation with care; the unit should not be carried by only one person if it is more than 20kg.
3. When installing the indoor unit and outdoor unit, a sufficient fixing bolt must be installed; make sure the installation support is firm.
4. Ware safety belt if the height of working is above 2m.
5. Use equipped components or appointed components during installation.
6. Make sure no foreign objects are left in the unit after finishing installation.

### Refrigerant Safety Precautions:

1. When refrigerant leaks or requires discharge during installation, maintenance, or disassembly, it should be handled by certified professionals or otherwise in compliance with local laws and regulations.
- 2.Avoid contact between refrigerant and fire as it generates poisonous gas; Prohibit prolong the connection pipe by welding.
3. Apply specified refrigerant only. Never have it mixed with any other refrigerant. Never have air remain in the refrigerant line as it may lead to rupture or other hazards.
4. Make sure no refrigerant gas is leaking out when installation is completed.
5. If there is refrigerant leakage, please take sufficient measure to minimize the density of refrigerant.
6. Never touch the refrigerant piping or compressor without wearing glove to avoid scald or frostbite.

**Improper installation may lead to fire hazard, explosion, electric shock or injury.**



## Safety Precautions for Installing and Relocating the Unit:

To ensure safety, please be mindful of the following precautions.

### WARNINGS

**1. When installing or relocating the unit, be sure to keep the refrigerant circuit free from air or substances other than the specified refrigerant.**

Any presence of air or other foreign substance in the refrigerant circuit will cause system pressure rise or compressor rupture, resulting in injury.

**2. When installing or moving this unit, do not charge the refrigerant which is not comply with that on the nameplate or unqualified refrigerant.**

Otherwise, it may cause abnormal operation, wrong action, mechanical malfunction or even series safety accident.

**3. When refrigerant needs to be recovered during relocating or repairing the unit, be sure that the unit is running in cooling mode. Then, fully close the valve at high pressure side (liquid valve). About 30-40 seconds later, fully close the valve at low pressure side (gas valve), immediately stop the unit and disconnect power. Please note that the time for refrigerant recovery should not exceed 1 minute.**

If refrigerant recovery takes too much time, air may be sucked in and cause pressure rise or compressor rupture, resulting in injury.

**4. During refrigerant recovery, make sure that liquid valve and gas valve are fully closed and power is disconnected before detaching the connection pipe.**

If compressor starts running when stop valve is open and connection pipe is not yet connected, air will be sucked in and cause pressure rise or compressor rupture, resulting in injury.

**5. When installing the unit, make sure that connection pipe is securely connected before the compressor starts running.**

If compressor starts running when stop valve is open and connection pipe is not yet connected, air will be sucked in and cause pressure rise or compressor rupture, resulting in injury.

**6. Prohibit installing the unit at the place where there may be leaked corrosive gas or flammable gas.**

If there leaked gas around the unit, it may cause explosion and other accidents.

**7. Do not use extension cords for electrical connections. If the electric wire is not long enough, please contact a local service center authorized and ask for a proper electric wire.**

Poor connections may lead to electric shock or fire.

**8. Use the specified types of wires for electrical connections between the indoor and outdoor units. Firmly clamp the wires so that their terminals receive no external stresses.**

Electric wires with insufficient capacity, wrong wire connections and insecure wire terminals may cause electric shock or fire.



## R32 refrigerant warning

- To realize the function of the air conditioner unit, a special refrigerant circulates in the system. The used refrigerant is the fluoride R32, which is specially cleaned. The refrigerant is flammable and odorless. Furthermore, it can lead to explosion under certain conditions. But the flammability of the refrigerant is very low. It can be ignited only by fire.
- Compared to common refrigerants, R32 is a nonpolluting refrigerant with no harm to the ozone layer. The influence upon the greenhouse effect is also lower. R32 has got very good thermodynamic features which lead to a really high energy efficiency. The units therefore need a less filling.
- This product uses R32 difluoromethane refrigerant, which is a mildly flammable gas class A2L according to ISO 817 or ANSI/ASHRAE 34.
- "ANSI/ASHRAE 15 (USA) and CSA 852 (Canada)" stipulate that it must be handled by a refrigeration mechanic with an appropriate refrigerant handling licence.
- The appliance shall be stored in a room without continuously operating ignition sources. (for example: open flames, an operating gas appliance or an operating electric heater.)
- The appliance shall be stored in a well-ventilated area where the room size corresponds to the room area as specified for operation.
- The appliance shall be stored so as to prevent mechanical damage from occurring.
- Ducts connected to an appliance shall not contain an ignition source.
- Keep any required ventilation openings clear of obstruction.
- Do not pierce or burn.
- Be aware that refrigerants may not contain an odour.
- Do not use means to accelerate the defrosting process or to clean, other than those recommended by the manufacturer.
- Servicing shall be performed only as recommended by the manufacturer.
- Should repair be necessary, contact your nearest authorized Service Centre. Any repairs carried out by unqualified personnel may be dangerous.
- Compliance with national gas regulations shall be observed. Read specialist's manual.



- That pipe-work including piping material, pipe routing, and installation shall include protection from physical damage in operation and service, and be in compliance with national and local codes and standards, such as ASHRAE 15, ASHRAE 15.2, IAPMO Uniform Mechanical Code, ICC

International Mechanical Code, or CSA B52. All field joints shall be accessible for inspection prior to being covered or enclosed.

### Safety Operation of Flammable Refrigerant Aptitude requirement for maintenance man (repairs should be done only by specialists).

- Any person who is involved with working on or breaking into a refrigerant circuit should hold a current valid certificate from an industry-accredited assessment authority, which authorises their competence to handle refrigerants safely in accordance with an industry recognised assessment specification.
- Servicing shall only be performed as recommended by the equipment manufacturer. Maintenance and repair requiring the assistance of other skilled personnel shall be carried out under the supervision of the person competent in the use of flammable refrigerants

### Safety preparation work

This product uses mildly flammable R32 refrigerant. Certain levels of refrigerant require minimum room sizes. Please ensure that these minimum room sizes are adhered to for standard installations. (Note: Please refer to the nameplate for the charging quantity of R32).

Appliance shall be installed, operated and stored in a room with a floor area larger than  $Xm^2$ . (Please refer to table "a")

table a - Minimum room area ( $m^2$ )

Charge amount (kg)	Height of ventilation opening (m)			
	0.6	1.8	2.2	2.5
Minimum room area ( $m^2$ )				
≤1.836	/	/	/	/
1.85	29.39	6.72	5.50	4.84
1.9	31.01	6.90	5.65	4.97
1.95	32.66	7.09	5.80	5.10
2	34.35	7.27	5.95	5.23
2.05	36.09	7.45	6.10	5.36
2.1	37.87	7.63	6.24	5.50
2.15	39.70	7.81	6.39	5.63
2.2	41.57	7.99	6.54	5.76
2.3	45.43	8.36	6.84	6.02
2.4	49.47	8.72	7.14	6.28
2.5	53.68	9.08	7.43	6.54
2.6	58.05	9.45	7.73	6.80
2.7	62.61	9.81	8.03	7.06
2.8	67.33	10.17	8.32	7.33
2.9	72.22	10.54	8.62	7.59
3	77.29	10.90	8.92	7.85
3.1	82.53	11.26	9.21	8.11
3.2	87.94	11.62	9.51	8.37
3.3	93.52	11.99	9.81	8.63
3.4	99.27	12.35	10.11	8.89
3.5	105.20	12.71	10.40	9.16

### Information on servicing

#### Checks to the area

Prior to beginning work on systems containing FLAMMABLE REFRIGERANTS, Safety checks are necessary to ensure that the risk of ignition is minimised. For repair to the REFRIGERATING SYSTEM, the following precautions shall be completed prior to

conducting work on the system.

### **Work procedure**

Work shall be undertaken under a controlled procedure so as to minimise the risk of a flammable gas or vapour being present while the work is being performed.

### **General work area**

All maintenance staff and others working in the local area shall be instructed on the nature of work being carried out. Work in confined spaces shall be avoided.

### **Checking for presence of refrigerant**

The area shall be checked with an appropriate refrigerant detector prior to and during work, to ensure the technician is aware of potentially toxic or flammable atmospheres. Ensure that the leak detection equipment being used is suitable for use with all applicable refrigerants, i.e. non-sparking, adequately sealed or intrinsically safe.

### **Presence of fire extinguisher**

If any hot work is to be conducted on the refrigerating equipment or any associated parts, appropriate fire extinguishing equipment shall be available to hand. Have a dry powder or CO<sub>2</sub> fire extinguisher adjacent to the charging area.

### **No ignition sources**

No person carrying out work in relation to a REFRIGERATING SYSTEM which involves exposing any pipe work shall use any sources of ignition in such a manner that it may lead to the risk of fire or explosion. All possible ignition sources, including cigarette smoking, should be kept sufficiently far away from the site of installation, repairing, removing and disposal, during which refrigerant can possibly be released to the surrounding space. Prior to work taking place, the area around the equipment is to be surveyed to make sure that there are no flammable hazards or ignition risks. "No Smoking" signs shall be displayed.

### **Ventilated area**

Ensure that the area is in the open or that it is adequately ventilated before breaking into the system or conducting any hot work. A degree of ventilation shall continue during the period that the work is carried out. The ventilation should safely disperse any released refrigerant and preferably expel it externally into the atmosphere.

### **Checks to the refrigerating equipment**

Where electrical components are being changed, they shall be fit for the purpose and to the correct specification. At all times the manufacturer's maintenance and service guidelines shall be followed. If in doubt, consult the manufacturer's technical department for assistance.

The following checks shall be applied to installations using FLAMMABLE REFRIGERANTS:

- the actual REFRIGERANT CHARGE is in accordance with the room size within which the refrigerant containing parts are installed.
- the ventilation machinery and outlets are operating adequately and are not obstructed;
- if an indirect refrigerating circuit is being used, the secondary circuit shall be checked for the presence of refrigerant;
- marking to the equipment continues to be visible and legible. Markings and signs that are illegible shall be corrected.
- refrigerating pipe or components are installed in a position where they are unlikely to be exposed to any substance which may corrode refrigerant containing components, unless the

components are constructed of materials which are inherently resistant to being corroded or are suitably protected against being so corroded.

### **Checks to electrical devices**

Repair and maintenance to electrical components shall include initial safety checks and component inspection procedures. If a fault exists that could compromise safety, then no electrical supply shall be connected to the circuit until it is satisfactorily dealt with. If the fault cannot be corrected immediately but it is necessary to continue operation, an adequate temporary solution shall be used. This shall be reported to the owner of the equipment so all parties are advised.

Initial safety checks shall include:

- that capacitors are discharged: this shall be done in a safe manner to avoid possibility of sparking;
- that no live electrical components and wiring are exposed while charging, recovering or purging the system;
- that there is continuity of earth bonding.

### **Repairs to sealed components**

Sealed electrical components shall be replaced.

### **Repair to intrinsically safe components**

Intrinsically safe components must be replaced.

### **Cabling**

Check that cabling will not be subject to wear, corrosion, excessive pressure, vibration, sharp edges or any other adverse environmental effects. The check shall also take into account the effects of aging or continual vibration from sources such as compressors or fans.

### **Detection of flammable refrigerants**

Under no circumstances shall potential sources of ignition be used in the searching for or detection of refrigerant leaks. A halide torch (or any other detector using a naked flame) shall not be used.

The following leak detection methods are deemed acceptable for all refrigerant systems.

Electronic leak detectors may be used to detect refrigerant leaks but, in the case of FLAMMABLE REFRIGERANTS, the sensitivity may not be adequate, or may need re-calibration. (Detection equipment shall be calibrated in a refrigerant-free area.) Ensure that the detector is not a potential source of ignition and is suitable for the refrigerant used. Leak detection equipment shall be set at a percentage of the LFL of the refrigerant and shall be calibrated to the refrigerant employed, and the appropriate percentage of gas (25% maximum) is confirmed.

Leak detection fluids are also suitable for use with most refrigerants but the use of detergents containing chlorine shall be avoided as the chlorine may react with the refrigerant and corrode the copper pipe-work.

NOTE Examples of leak detection fluids are

- bubble method,
- fluorescent method agents

If a leak is suspected, all naked flames shall be removed/ extinguished.

If a leakage of refrigerant is found which requires brazing, all of the refrigerant shall be recovered from the system, or isolated

(by means of shut off valves) in a part of the system remote from the leak. Removal of refrigerant shall be according to Clause "Removal and evacuation".

## Removal and evacuation

When breaking into the refrigerant circuit to make repairs -or for any other purpose -conventional procedures shall be used. However,for flammable refrigerants it is important that best practice be followed,since flammability is a consideration. The following procedure shall be adhered to:

- Safely remove refrigerant following local and national regulations;
- evacuate;
- purge the circuit with inert gas (optional for A2L);
- evacuate (optionalforA2L);
- continuously flush or purge with inert gas when using flame to open circuit;and
- open the circuit.

The refrigerant charge shall be recovered into the correct recovery cylinders if venting is not allowed by local and national codes. For appliances containing flammable refrigerants,the system shall be purged with oxygen-free nitrogen to render the appliance safe for flammable refrigerants. This process might need to be repeated several times. Compressed air or oxygen shall not be used for purging refrigerant systems.

For appliances containing flammable refrigerants,refrigerants purging shall be achieved by breaking the vacuum in the system with oxygen-free nitrogen and continuing to fill until the working pressure is achieved,then venting to atmosphere,and finally pulling down to a vacuum (optional for A2L).This process shall be repeated until no refrigerant is within the system (optional for A2L). When the final oxygen-free nitrogen charge is used,the system shall be vented down to atmospheric pressure to enable work to take place.

The outlet for the vacuum pump shall not be close to any potential ignition sources,and ventilation shall be available

## Charging procedures

In addition to conventional charging procedures,the following requirements shall be followed.

- Ensure that contamination of different refrigerants does not occur when using charging equipment.
- Hoses or lines shall be as short as possible to minimise the amount of refrigerant contained in them.
- Cylinders shall be kept in an appropriate position according to the instructions.
  - Ensure that the REFRIGERATING SYSTEM is earthed prior to charging the system with refrigerant.
  - Label the system when charging is complete(if not already).
  - Extreme care shall be taken not to overfill the REFRIGERATING SYSTEM.

Prior to recharging the system, it shall be pressure-tested with the appropriate purging gas. The system shall be leak-tested on completion of charging but prior to commissioning. A follow up leak test shall be carried out prior to leaving the site.

## Decommissioning

Before carrying out this procedure,it is essential that the technician is completely familiar with the equipment and all its detail.It is recommended good practice that all refrigerants are recovered

safely. Prior to the task being carried out,an oil and refrigerant sample shall be taken in case analysis is required prior to re-use of recovered refrigerant. It is essential that electrical power is available before the task is commenced.

- a) Become familiar with the equipment and its operation.
- b) Isolate system electrically
- c) Before attempting the procedure,ensure that:
  - mechanical handling equipment is available, if required,for handling refrigerant cylinders;
  - all personal protective equipment isavailable and being used correctly;
  - the recovery process is supervised at all times by a competent person;
  - recovery equipment and cylinders conform to the appropriate standards.
- d) Pump down refrigerant system,if possible
- e) If a vacuum is not possible,make a manifold so that refrigerant can be removed from various parts of the system.
- f) Make sure that cylinder is situated on the scales before recovery takes place
- g) Start the recovery machine and operate in accordance with instructions
- h) Do not overfill cylinders (no more than 80 % volume liquid charge.
- i) Do not exceed the maximum working pressure of the cylinder even temporarily.
- j) When the cylinders have been filled correctly and the process completed, make sure that the cylinders and the equipment are removed from site promptly and all isolation valves on the equipment are closed off.
- k) Recovered refrigerant shall not be charged into another REFRIGERATING SYSTEM unless it has been cleaned and checked.

## Labelling

Equipment shall be labelled stating that it has been de-commissioned and emptied of refrigerant. The label shall be dated and signed. For appliances containing FLAMMABLE REFRIGERANTS,ensure that there are labels on the equipment stating the equipment contains FLAMMABLE REFRIGERANT.

## Recovery

When removing refrigerant from a system, either for servicing or decommissioning, it is recommended good practice that all refrigerants are removed safely.

When transferring refrigerant into cylinders,ensure that only appropriate refrigerant recovery cylinders are employed. Ensure that the correct number of cylinders for holding the total system charge is available. All cylinders to be used are designated for the recovered refrigerant and labelled for that refrigerant (i.e. special cylinders for the recovery of refrigerant). Cylinders shall be complete with pressure-relief valve and associated shut-off valves in good working order. Empty recovery cylinders are evacuated and,if possible cooled before recovery occurs.

The recovery equipment shall be in good working order with a set of instructions concerning the equipment that is at hand and shall be suitable for the recovery of the flammable refrigerant. If in doubt,the manufacturer should be consulted. In addition,a set of calibrated weighing scales shall be available and in good

working order. Hoses shall be complete with leak-free disconnect couplings and in good condition.

The recovered refrigerant shall be processed according to local legislation in the correct recovery cylinder, and the relevant waste transfer note arranged. Do not mix refrigerants in recovery units and especially not in cylinders.

If compressors or compressor oils are to be removed, ensure that they have been evacuated to an acceptable level to make certain that flammable refrigerant does not remain within the lubricant.

The compressor body shall not be heated by an open flame or other ignition sources to accelerate this process. When oil is drained from a system, it shall be carried out safely.

## Main Tools for Installation and Maintenance



Level meter



Measuring tape



Screw driver



Impact drill



Drill head



Electric drill



Electroprobe



Universal meter



Torque wrench



Open-end wrench



Inner hexagon spanner



Electronic leakage detector



Vacuum pump



Pressure meter



Pipe pliers



Pipe pliers



Pipe cutter



Pipe expander



Pipe bender



Soldering appliance



Refrigerant container



Electronic scale

# 8. Installation

## 8.1 Installation Dimension Diagram

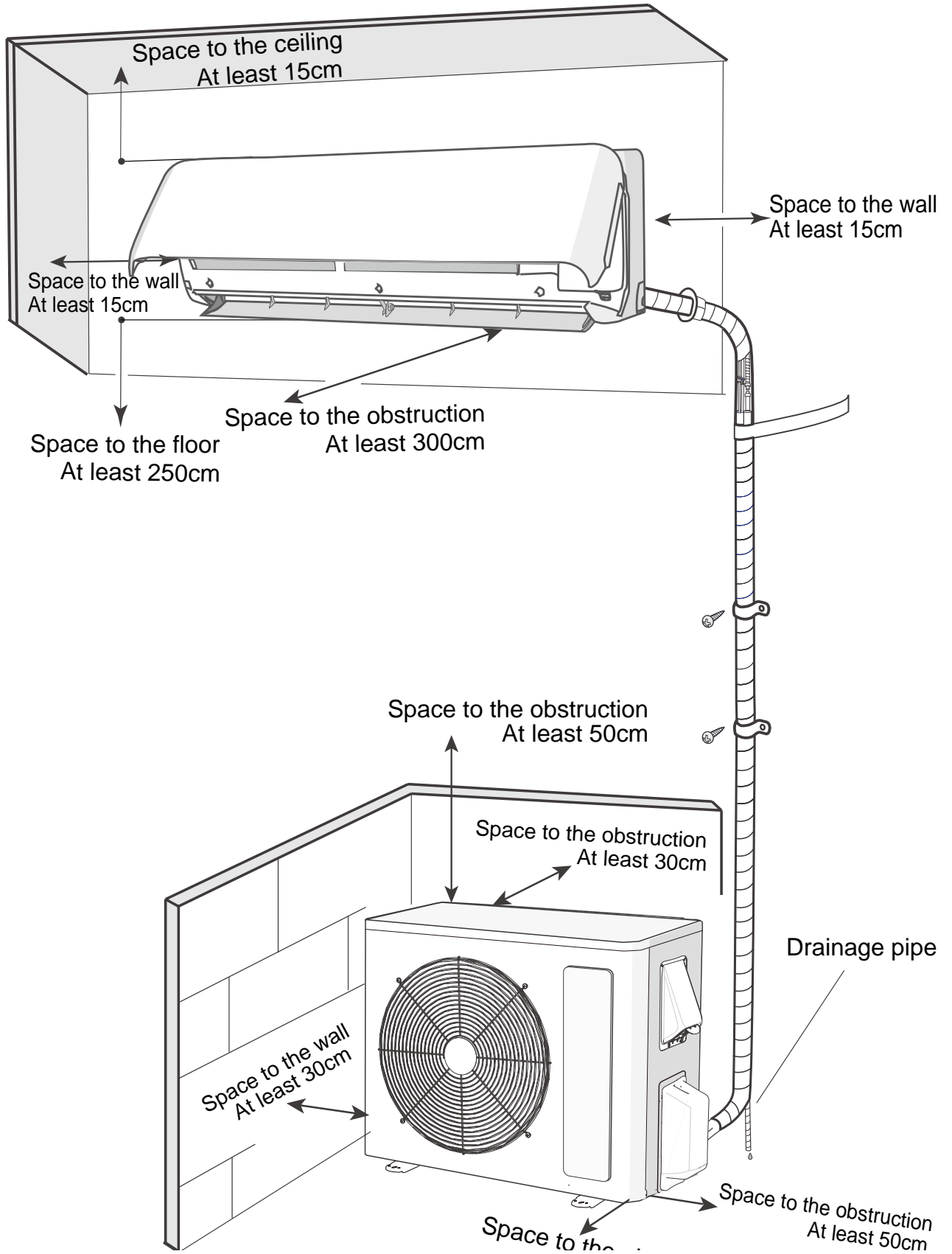

## Installation Procedures

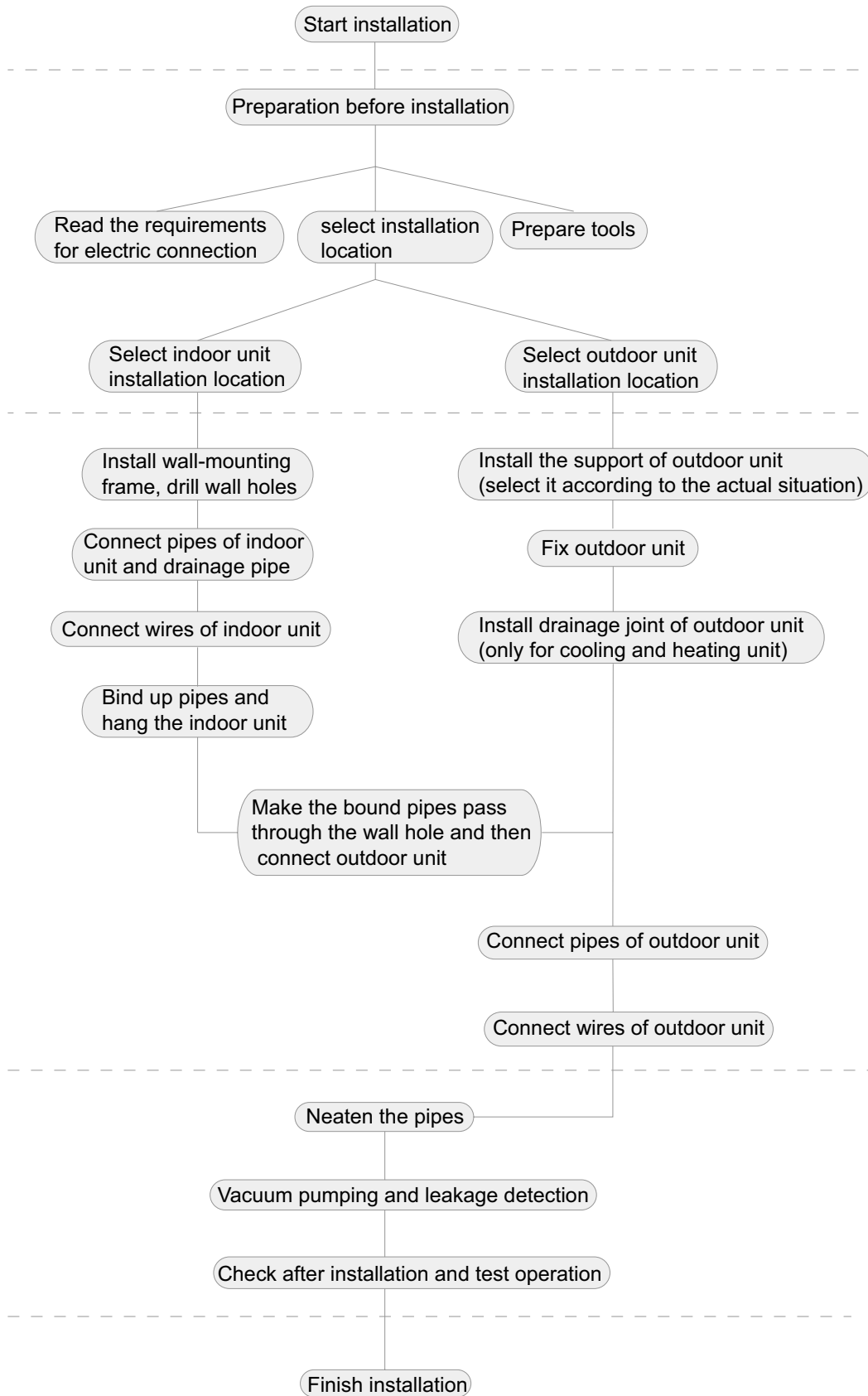

Note: this flow is only for reference; please find the more detailed installation steps in this se



## 8.2 Installation Parts-checking

No.	Name
1	Indoor unit
2	Outdoor unit
3	Connection pipe
4	Drainage pipe
5	Wall-mounting frame
6	Connecting cable(power supply cord)
7	Wall pipe
8	Sealing gum
9	Wrapping tape
10	Support of outdoor unit
11	Fixing screw
12	Drainage plug(cooling and heating unit)
13	Owners manual, remote controller

### ⚠ Note:

1. Please contact the local agent for installation.
2. Don't use unqualified power supply cord.

## 8.3 Selection of Installation Location

### 1. Basic Requirement:

Installing the unit in the following places may cause malfunction. If it is unavoidable, please consult the local dealer:

- (1) The place with strong heat sources, vapors, flammable or explosive gas, or volatile objects spread in the air.
- (2) The place with high-frequency devices (such as welding machine, medical equipment).
- (3) The place near coast area.
- (4) The place with oil or fumes in the air.
- (5) The place with sulfured gas.
- (6) Other places with special circumstances.
- (7) The appliance shall not be installed in the laundry.
- (8) It's not allowed to be installed on the unstable or motive base structure (such as truck) or in the corrosive environment (such as chemical factory).

### 2. Indoor unit:

- (1) There should be no obstruction near air inlet and air outlet.
- (2) Select a location where the condensation water can be dispersed easily and won't affect other people.
- (3) Select a location which is convenient to connect the outdoor unit and near the power socket.
- (4) Select a location which is out of reach for children.
- (5) The location should be able to withstand the weight of indoor unit and won't increase noise and vibration.
- (6) The appliance must be installed 2.5m above floor.
- (7) Don't install the indoor unit right above the electric appliance.
- (8) Please try your best to keep away from fluorescent lamp.

### 3. Outdoor Unit:

- (1) Select a location where the noise and outflow air emitted by the outdoor unit will not affect neighborhood.
- (2) The location should be well ventilated and dry, in which the outdoor unit won't be exposed directly to sunlight or strong wind.
- (3) The location should be able to withstand the weight of outdoor unit.
- (4) Make sure that the installation follows the requirement of installation dimension diagram.
- (5) Select a location which is out of reach for children and far away from animals or plants. If it is unavoidable, please add fence for safety purpose.

## 8.4 Electric Connection Requirement

### 1. Safety Precaution

- (1) Must follow the electric safety regulations when installing the unit.
- (2) According to the local safety regulations, use qualified power supply circuit and air switch.
- (3) Make sure the power supply matches with the requirement of air conditioner. Unstable power supply or incorrect wiring may result in electric shock, fire hazard or malfunction. Please install proper power supply cables before using the air conditioner.
- (4) Properly connect the live wire, neutral wire and grounding wire of power socket.
- (5) Be sure to cut off the power supply before proceeding any work related to electricity and safety.
- (6) Do not put through the power before finishing installation.
- (7) If the supply cord is damaged, it must be replaced by the manufacturer, its service agent or similarly qualified persons in order to avoid a hazard.
- (8) The temperature of refrigerant circuit will be high, please keep the interconnection cable away from the copper tube.
- (9) The appliance shall be installed in accordance with national wiring regulations.

### 2. Grounding Requirement:

- (1) The air conditioner is the first class electric appliance. It must be properly grounded with specialized grounding device by a professional.

Please make sure it is always grounded effectively, otherwise it may cause electric shock.

- (2) The yellow-green wire in air conditioner is grounding wire, which can't be used for other purposes.
- (3) The grounding resistance should comply with national electric safety regulations.
- (4) An all-pole disconnection switch having a contact separation of at least 3mm in all poles should be connected in fixed wiring.
- (5) Including an air switch with suitable capacity, please note the following nameplate. Air switch should be included magnet buckle and heating buckle function, it can protect the circuit-short and overload. (Caution: please do not use the fuse only for protect the circuit)

## 8.5 Installation of Indoor Unit

### 1. Choosing Installation location

Recommend the installation location to the client and then confirm it with the client.

### 2. install wall-mounting frame

(1) Hang the wall-mounting frame on the wall; adjust it in horizontal position with the level meter and then point out the screw fixing holes on the wall.

(2) Drill the screw fixing holes on the wall with impact drill (the specification of drill head should be the same as the plastic expansion particle) and then fill the plastic expansion particles in the holes.

(3) Fix the wall-mounting frame on the wall with tapping screws and then check if the frame is firmly installed by pulling the frame. If the plastic expansion particle is loose, please drill another fixing hole nearby.

#### Note:

(1) Pay attention to dust prevention and take relevant safety measures when opening the hole.

(2) The plastic expansion particles are not provided.

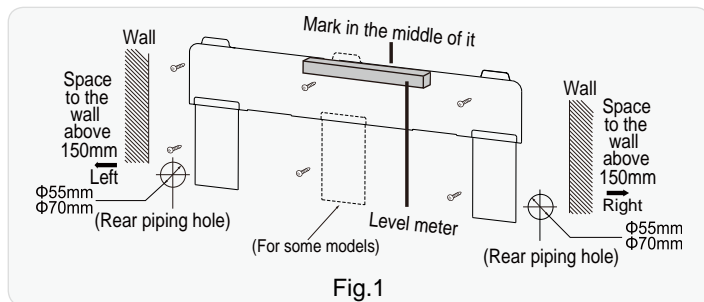

### 3. Drill Piping Hole

(1) Choose the position of piping hole according to the direction of outlet pipe. The position of piping hole should be a little lower than the wall-mounted frame, shown as below. (As show in Fig.1)

(2) Open a piping hole with the diameter of  $\Phi 55\text{mm}$  or  $\Phi 70\text{mm}$  on the selected outlet pipe position. In order to drain smoothly, slant the piping hole on the wall slightly downward to the outdoor side with the gradient of  $5\text{-}10^\circ$ . (As show in Fig.2)

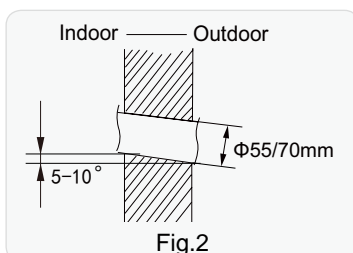

### 4. Outlet Pipe

(1) The pipe can be led out in the direction of right, rear right, left or rear left. (As show in Fig.3)

(2) When selecting leading out the pipe from left or right, please cut off the corresponding hole on the bottom case. (As show in Fig.4)

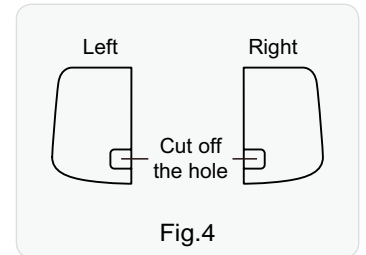
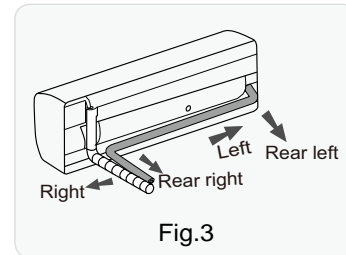

### 5. Connect the Pipe of Indoor Unit

(1) Aim the pipe joint at the corresponding bellmouth. (As show in Fig.5)

(2) Pretightening the union nut with hand.

(3) Adjust the torque force by referring to the following sheet. Place the open-end wrench on the pipe joint and place the torque wrench on the union nut. Tighten the union nut with torque wrench. (As show in Fig.6)

(4) Wrap the indoor pipe and joint of connection pipe with insulating pipe, and then wrap it with tape. (As show in Fig.7)

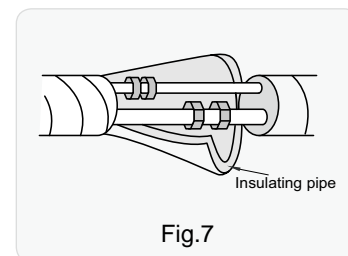
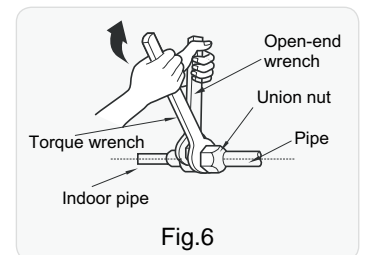
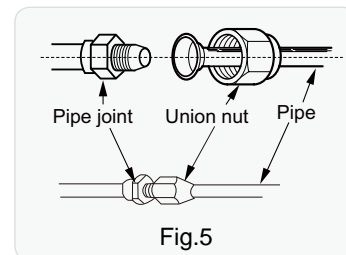

Refer to the following table for wrench moment of force:

Piping size(inch)	Tightening torque(N·m)
1/4	15~20
3/8	30~40
1/2	45~55
5/8	60~65
3/4	70~75

## 6. install drain hose

(1) Connect the drain hose to the outlet pipe of indoor unit.(As show in Fig.8)

(2) Bind the joint with tape.(As show in Fig.9)

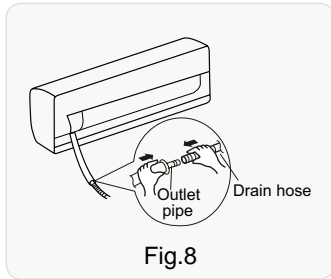

Fig.8

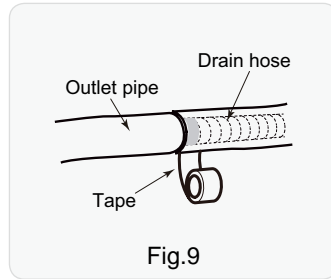

Fig.9

### Note:

Add insulating pipe in the indoor drain hose in order to prevent condensation.(As show in Fig.10)

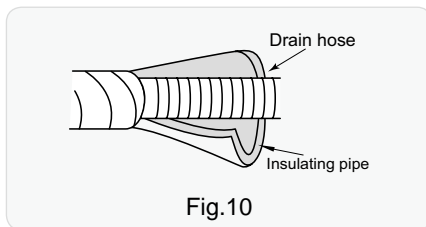

Fig.10

## 7. connect wire of indoor unit

(1) Open the panel, remove the screw on the wiring cover and then take down the cover.(As show in Fig.11)

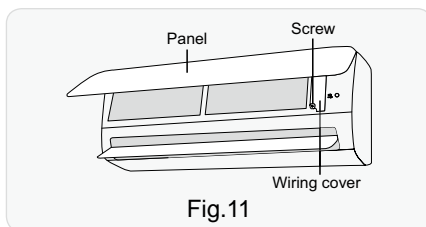

Fig.11

(2) Fix the connection wire sleeve on wire crossing board of the bottom case; the power connection wire passes through the wire crossing hole at the back of indoor unit shell after passing through the connection wire sleeve, and then pulls it out from the front. (As show in Fig.12)

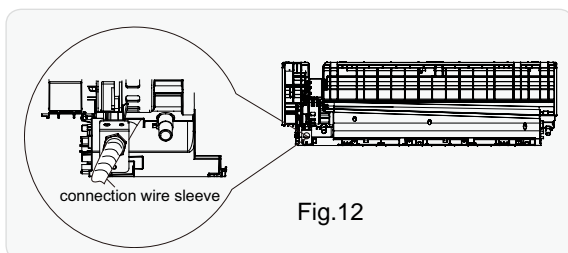

Fig.12

(3) Remove the wire clip; connect the power connection wire to the wiring terminal according to the color; tighten the screw and then fix the power connection wire with wire clip.(As show in Fig.13)

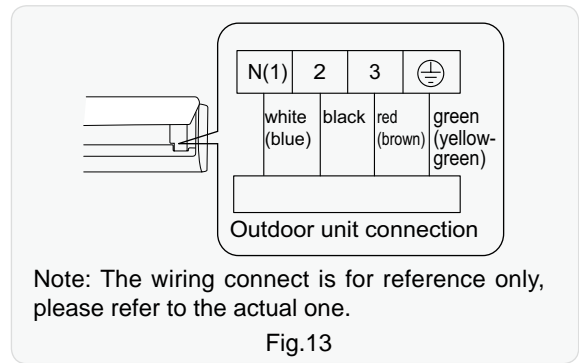

Fig.13

Model	power connection wire
9~36K	4x AWG18

(4) Put wiring cover back and then tighten the screw.

(5) Close the panel.

### ⚠ WARNING

(1) All wires of indoor unit and outdoor unit should be connected by a professional.

(2) If the length of power connection wire is insufficient, please contact the supplier for a new one. Avoid extending the wire by yourself.

## 8. Bind up Pipe

(1) Bind up the connection pipe and drain hose with the band.(As show in Fig.14)

(2) Reserve a certain length of drain hose for installation when binding them. When binding to a certain degree, separate the drain hose.(As show in Fig.15)

(3) Bind them evenly.

(4) The liquid pipe and gas pipe should be bound separately at the end.

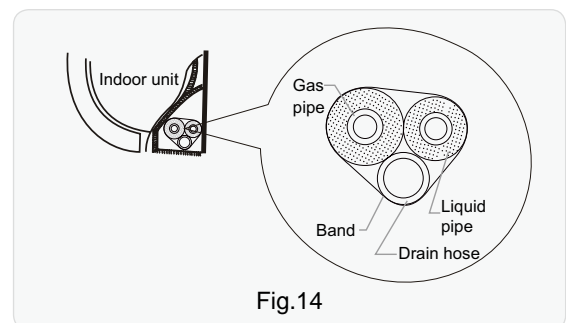

Fig.14

### NOTICE:

The drain hose should be bound at the bottom.

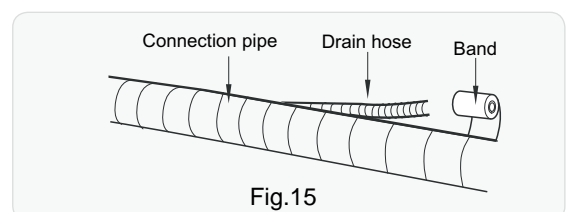

Fig.15

## 9. Hang the Indoor Unit

- (1) Put the bound pipes in the wall pipe and then make them pass through the wall hole.
- (2) Hang the indoor unit on the wall-mounting frame.
- (3) Stuff the gap between pipes and wall hole with sealing gum.
- (4) Fix the wall pipe.(As show in Fig.16)
- (5) Check if the indoor unit is installed firmly and closed to the wall.(As show in Fig.17)

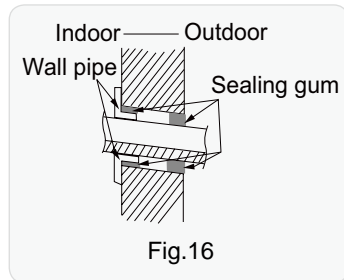

Fig.16

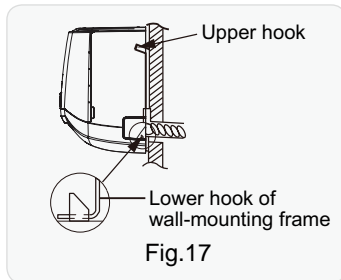

Fig.17

### Note:

Do not bend the drain hose too excessively in order to prevent blocking.

## 8.6 Installation of Outdoor unit

### 1. Fix the Support of Outdoor Unit(Select it according to the actual installation situation)

- (1) Select installation location according to the house structure.
- (2) Fix the support of outdoor unit on the selected location with expansion screws.

### Note:

- (1) Take sufficient protective measures when installing the outdoor unit.
- (2) Make sure the support can withstand at least four times the unit weight.
- (3) The outdoor unit should be installed at least 3cm above the floor in order to install drain joint.(As show in Fig.18)
- (4) For the unit with cooling capacity of 2300W~5000W, 6 expansion screws are needed; for the unit with cooling capacity of 6000W~8000W, 8 expansion screws are needed; for the unit with cooling capacity of 10000W~16000W, 10 expansion screws are needed.

### 2. Install Drain Joint(Only for cooling and heating unit)

- (1) Connect the outdoor drain joint into the hole on the chassis.
  - (2) Connect the drain hose into the drain vent.
- (As show in Fig.19)

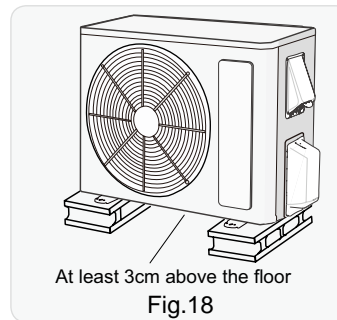

Fig.18

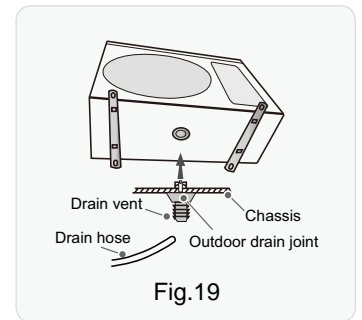

Fig.19

### 3. Fix Outdoor Unit

- (1) Place the outdoor unit on the support.
  - (2) Fix the foot holes of outdoor unit with bolts.
- (As show in Fig.20)

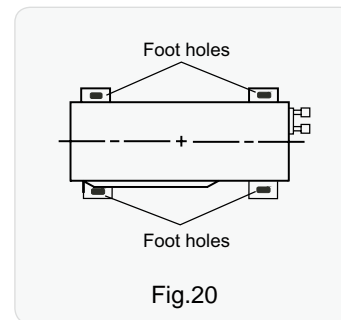

Fig.20

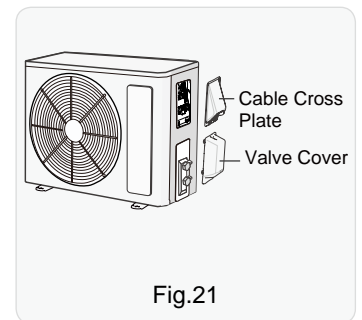

Fig.21

### 4. Connect Indoor and Outdoor Pipes

- (1) Remove the screw on the valve cover of outdoor unit and then remove the valve cover.(As show in Fig.21)
- (2) Remove the screw cap of valve and aim the pipe joint at the bellmouth of pipe.(As show in Fig.22)

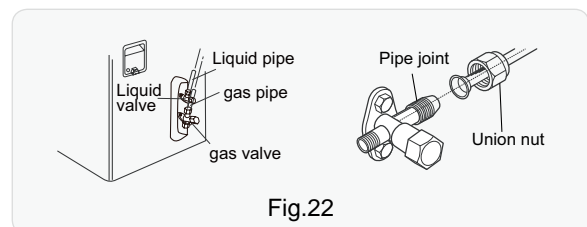

Fig.22

- (3) Pretightening the union nut with hand.
- (4) Tighten the union nut with torque wrench .

Refer to the following table for wrench moment of force:

Piping size(inch)	Tightening torque(N·m)
1/4	15~20
3/8	30~40
1/2	45~55
5/8	60~65
3/4	70~75

## 5. Connect Outdoor Electric Wire

- (1) Remove the screw on the cable cross plate, then remove it.
- (2) Let the connection wire sleeve go through the two holes of baffle; tighten the connection joint of sleeve and cable cross plate; remove the wire clip; connect the power connection wire and power supply cord to the wiring terminal according to the color; fix them with screws. (As show in Fig.23)
- (3) Fix the power connection wire and power supply cord with wire clip.
- (4) Fix the cable cross plate on right side plate with screw.

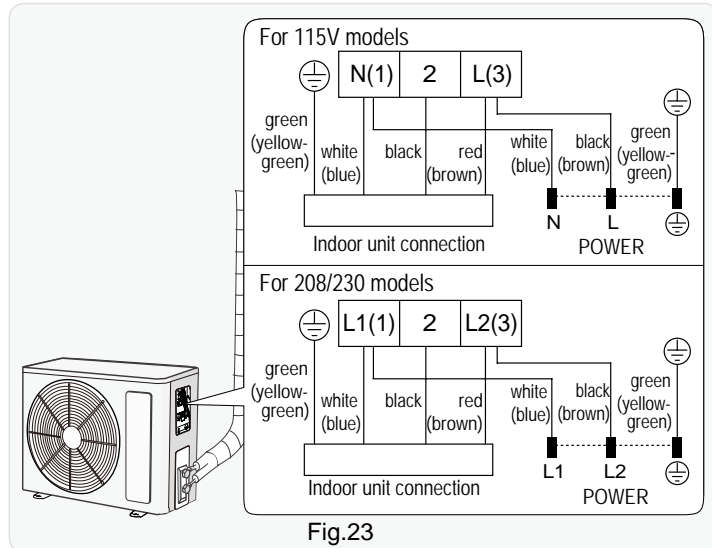

Note: the wiring connect is for reference only, please refer to the actual one.

### ⚠ CAUTION

- (1) After tightening the screw, pull the power supply cord slightly to check if it is firm.
- (2) Never cut the power connection wire to prolong or shorten the distance.
- (3) The power connection wire and connection pipe can't touch each other.
- (4) Top cover of outdoor unit and electric box assembly should be fixed by the screw. Otherwise, it can cause a fire, or short circuit caused by water or dust.
- (5) For the air conditioner without plug, an air switch must be installed in the line. The air switch should be all-pole parting and the contact parting distance should be more than 3mm.

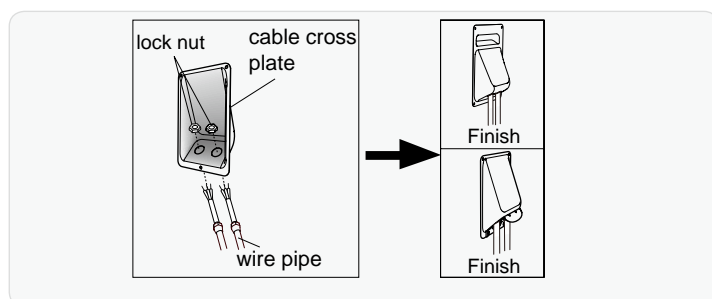

## 6. Neaten the Pipes

- (1) The pipes should be placed along the wall, bent reasonably and hidden possibly. Min. semidiameter of bending the pipe is 10cm.
- (2) If the outdoor unit is higher than the wall hole, you must set a U-shaped curve in the pipe before pipe goes into the room, in order to prevent rain from getting into the room. (As show in Fig.24)

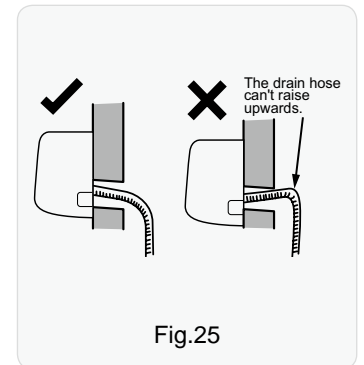
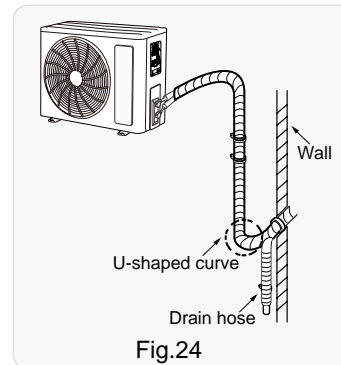

### Note:

- (1) The through-wall height of drain hose shouldnt be higher than the outlet pipe hole of indoor unit. (As show in Fig.25)
- (2) Slant the drain hose slightly downwards. The drain hose can't be curved, raised and fluctuant, etc. (As show in Fig.26)
- (3) The water outlet can't be placed in water in order to drain smoothly. (As show in Fig.27)

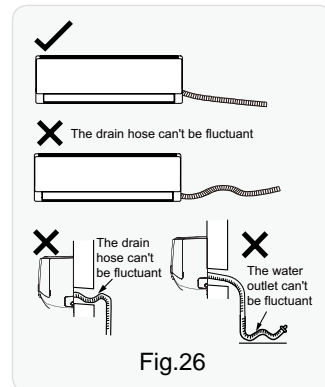

## 8.7 Vacuum Pumping and Leak Detection

### 1. Use Vacuum Pump

(1) Remove the valve caps on the liquid valve and gas valve and the nut of refrigerant charging vent.

(2) Connect the charging hose of piezometer to the refrigerant charging vent of gas valve and then connect the other charging hose to the vacuum pump.

(3) Open the piezometer completely and operate for 10-15min to check if the pressure of piezometer remains in -0.1MPa.

(4) Close the vacuum pump and maintain this status for 1-2min to check if the pressure of piezometer remains in -0.1MPa. If the pressure decreases, there may be leakage.

(5) Remove the piezometer, open the valve core of liquid valve and gas valve completely with inner hexagon spanner.

(6) Tighten the screw caps of valves and refrigerant charging vent.(As show in Fig.28)

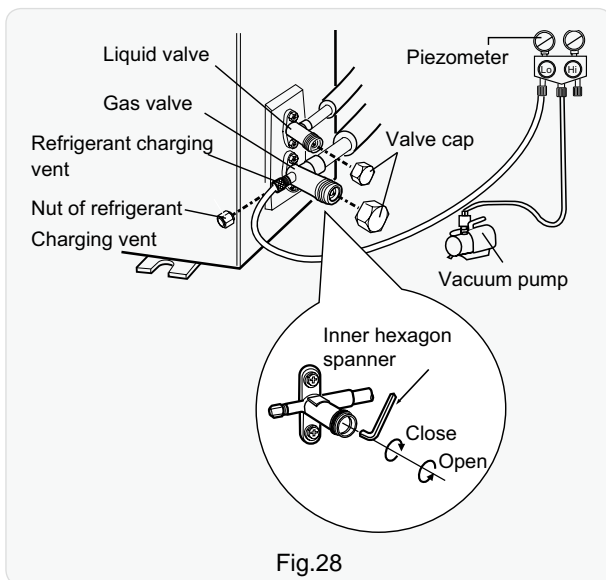

Fig.28

### 2. Leakage Detection

#### (1) With leakage detector:

Check if there is leakage with leakage detector.

#### (2) With soap water:

If leakage detector is not available, please use soap water for leakage detection. Apply soap water at the suspected position and keep the soap water for more than 3min. If there are air bubbles coming out of this position, there's a leakage.

## 8.8 Check after Installation and Test operation

### 1. Check after Installation

Check according to the following requirement after finishing installation.

NO.	Items to be checked	Possible malfunction
1	Has the unit been installed firmly?	The unit may drop, shake or emit noise.
2	Have you done the refrigerant leakage test?	It may cause insufficient cooling (heating) capacity.
3	Is heat insulation of pipeline sufficient?	It may cause condensation and water dripping.
4	Is water drained well?	It may cause condensation and water dripping.
5	Is the voltage of power supply according to the voltage marked on the nameplate?	It may cause malfunction or damage the parts.
6	Is electric wiring and pipeline installed correctly?	It may cause malfunction or damage the parts.
7	Is the unit grounded securely?	It may cause electric leakage.
8	Does the power supply cord follow the specification?	It may cause malfunction or damage the parts.
9	Is there any obstruction in air inlet and air outlet?	It may cause insufficient cooling (heating) capacity.
10	The dust and sundries caused during installation are removed?	It may cause malfunction or damaging the parts.
11	The gas valve and liquid valve of connection pipe are open completely?	It may cause insufficient cooling (heating) capacity.
12	Is the inlet and outlet of piping hole been covered?	It may cause insufficient cooling(heating) capacity or waster eletricity.

### 2. Test Operation

#### (1) Preparation of test operation

- The client approves the air conditioner installation.
- Specify the important notes for air conditioner to the client.

#### (2) Method of test operation

- Put through the power, press ON/OFF button on the remote controller to start operation.
- Press MODE button to select AUTO, COOL, DRY, FAN and HEAT to check whether the operation is normal or not.
- If the ambient temperature is lower than 16°C, the air conditioner can't start cooling.

# 9. Maintenance

## 9.1 Error Code List

Error code	Malfunction name	AC status	Possible causes
<b>C5</b>	Malfunction of jumper cap	The complete unit stops operation	<ol style="list-style-type: none"> <li>1. Jumper cap is not installed in control panel;</li> <li>2. Poor contact of jumper cap;</li> <li>3. Jumper cap is damaged;</li> <li>4. The tested circuit of jumper cap on control panel is abnormal.</li> </ol>
<b>E6</b>	Communication malfunction between indoor unit and outdoor unit	Cool: compressor stops operation, while indoor fan operates; Heat: all loads stops operation.	See "Communication malfunction"
<b>H5</b>	IPM protection	Cool/Dry: compressor stops operation, while indoor fan operates. Heat: all loads stops operation.	See "IPM protection, over-phase current of compressor"
<b>L3 LA</b>	Malfunction of outdoor fan/ malfunction of DC motor	Cool/Dry: all loads stops operation except indoor fan. Heat: all loads stops operation.	<ol style="list-style-type: none"> <li>1. Outdoor condenser, air inlet and air outlet are blocked by filth or dirt;</li> <li>2. Fan is blocked or loosened;</li> <li>3. Motor or connection wire of motor is damaged;</li> <li>4. Main board of outdoor unit is damaged;</li> </ol> (As for dual-outdoor fan, L3 indicates fan 1; LA indicates fan 2)
<b>H3</b>	Overload protection of compressor	Cool/Dry: compressor stops operation, while indoor fan operates. Heat: all loads stops operation.	<ol style="list-style-type: none"> <li>1. Overload wire of compressor is loose;</li> <li>2. The overload protector is damaged. Under normal circumstances, the resistance between both ends of terminal is less than 1ohm.</li> <li>3. See "Overload protection of compressor , High discharge temperature protection of compressor"</li> </ol>
<b>F0</b>	Refrigerant insufficient protection, cut-off protection of refrigerant	Cool: compressor and outdoor fan stops operation, while indoor fan operates; Heat: Compressor, outdoor fan and indoor fan stops operation.	<ol style="list-style-type: none"> <li>1. Is system cooling under high humidity environment, thus temperature difference of heat transfer is small;</li> <li>2. Check whether the big valve and small valve of outdoor unit are opened completely;</li> <li>3. Is the temperature sensor of evaporator of indoor unit loose?</li> <li>4. Is the temperature sensor of condenser of outdoor unit loose?</li> <li>5. Is the capillary or the electronic expansion valve blocked?</li> <li>6. Is refrigerant leaking?</li> </ol>
<b>F1</b>	Indoor ambient temperature sensor is open/short-circuited	Cool/Dry: indoor fan operates, while compressor and outdoor fan stops operation; Heat: all loads stops operation.	<ol style="list-style-type: none"> <li>1. Temperature sensor is not well connected;</li> <li>2. Temperature sensor is damaged</li> <li>3. Main board of indoor unit is damaged.</li> </ol>
<b>F2</b>	Indoor evaporator temperature sensor is open/short-circuited	Cool/Dry: indoor fan operates, while compressor and outdoor fan stops operation; Heat: all loads stops operation.	<ol style="list-style-type: none"> <li>1. Temperature sensor is not well connected;</li> <li>2. Temperature sensor is damaged</li> <li>3. Main board of indoor unit is damaged.</li> </ol>
<b>H6</b>	No feedback from indoor unit's motor	The complete unit stops operation	<ol style="list-style-type: none"> <li>1. Is the fan blocked?</li> <li>2. Is the motor terminal loose?</li> <li>3. Is the connection wire of motor damaged?</li> <li>4. Is the motor damaged?</li> <li>5. Is the main board of indoor unit damaged?</li> </ol>
<b>LP</b>	Indoor unit and outdoor can be matched with each other	Heat: compressor, outdoor unit and indoor fan stops operation.	Capacity of indoor unit and outdoor unit can't be matched.
<b>C4</b>	Malfunction of jumper cap of outdoor unit	Heat: all loads are stopped; other modes: outdoor unit stops operation.	Jumper cap of outdoor unit hasn't been installed.
<b>b7</b>	Gas valve temperature sensor is ON / short-circuited		<ol style="list-style-type: none"> <li>1. Temperature sensor is not well connected or damaged;</li> <li>2. The wire of temperature sensor is damaged, causing short circuit to copper pipe or outer casing;</li> <li>3. Main board of outdoor unit is damaged.</li> </ol>

Error code	Malfunction name	AC status	Possible causes
<b>b5</b>	Liquid valve temperature sensor is ON / short-circuited		<ol style="list-style-type: none"> <li>1. Temperature sensor is not well connected or damaged;</li> <li>2. The wire of temperature sensor is damaged, causing short circuit to copper pipe or outer casing;</li> <li>3. Main board of outdoor unit is damaged.</li> </ol>
<b>E1</b>	High pressure protection of system	Cool/Dry: all loads stops operation except indoor fan; Heat: all loads stops operation.	<ol style="list-style-type: none"> <li>1. Heat exchange of outdoor unit is too dirty, or it blocked the air inlet/outlet;</li> <li>2. Is power voltage normal; (three-phase unit)</li> <li>3. Ambient temperature is too high;</li> <li>4. Wiring of high pressure switch is loose or high pressure switch is damaged;</li> <li>5. The internal system is blocked; (dirt blockage, ice blockage, oil blockage, angle valve is not completely opened)</li> <li>6. Main board of outdoor unit is damaged;</li> <li>7. Refrigerant is too much.</li> </ol>
<b>E3</b>	Low pressure/low system pressure protection/ compressor low pressure protection	Cool: compressor, outdoor fan and indoor fan stop operation; Heat: compressor and outdoor fan stop operation at first. About 1min later, indoor fan stops operation; 2mins later, the 4-way valve stop operation.	<ol style="list-style-type: none"> <li>1. Low pressure switch is damaged;</li> <li>2. Refrigerant inside the system is insufficient.</li> </ol>
<b>E4</b>	High discharge temperature protection of compressor	Cool/Dry: compressor and outdoor fan stops operation, while indoor fan operates; Heat: all loads stops operation.	See "Overload protection of compressor , High discharge temperature protection of compressor"
<b>E5</b>	AC overcurrent protection	Cool/Dry: compressor and outdoor fan stops operation, while indoor fan operates; Heat: all loads stops operation.	<ol style="list-style-type: none"> <li>1. Power voltage is unstable;</li> <li>2. Power voltage is too low;</li> <li>3. System load is too high, which leads to high current;</li> <li>4. Heat exchange of indoor unit is too dirty, or it blocked the air inlet/outlet;</li> <li>5. Fan motor operation is abnormal; the fan speed is too low or not functioning;</li> <li>6. Compressor is blocked;</li> <li>7. The internal system is blocked; (dirt blockage, ice blockage, oil blockage, angle valve is not completely opened)</li> <li>8. Main board of outdoor unit is damaged.</li> </ol> See "AC overcurrent protection"
<b>E7</b>	Mode shock/sysmte mode shock	Load of indoor unit stops operation (indoor fan, E-heater, swing)	Malfunction of one-to-more system; there may be two indoor units which has set the shock mode, such as one is cooling and the other is heating.
<b>E8</b>	High temperature prevention protection	Cool: compressor stops operation while indoor fan operates; Heat: all loads stops operation.	See "High temperature prevention protection; high power; system isabnormal"
<b>EE</b>	Malfunction of EEPROM	Cool/Dry: compressor stops operation, while indoor fan operates; Heat: all loads stops operation.	Main board of outdoor unit is damaged.
<b>F0</b>	Refrigerant-recovery mode	Cool/Dry: compressor and outdoor fan stops operation, while indoor fan operates.	Refrigerant recovery. The maintenance personnel operate it when he is maintaining the unit.
<b>F3</b>	Outdoor ambient temperature is open/short-circuited	Cool/Dry: compressor and outdoor fan stop operation, while indoor fan operates; Heat: all loads stops operation.	<ol style="list-style-type: none"> <li>1. Temperature sensor is not connected well or damaged;</li> <li>2. Temperature sensor wire of outdoor unit is damaged; short circuit between the temperature sensor and copper pipe or outer case</li> <li>3. Main board of outdoor unit is damaged;</li> </ol>



Error code	Malfunction name	AC status	Possible causes
F4	Outdoor condenser temperature sensor is open/short-circuited	Cool/Dry: compressor and outdoor fan stop operation, while indoor fan operates; Heat: after operating for 3mins, all loads stops operation.	1. Temperature sensor is not connected well or damaged; 2. Temperature sensor wire of outdoor unit is damaged; short circuit between the temperature sensor and copper pipe or outer case; 3. Main board of outdoor unit is damaged.
F5	Outdoor air discharge temperature is open/short-circuited	Complete unit stops operation; motor of sliding door is cut off power.	1. The exhaust temperature sensor is not connected well or damaged. 2. Temperature sensor wire of outdoor unit is damaged; short circuit between the temperature sensor and copper pipe or outer case 3. Main board of outdoor unit is damaged;
FC	Malfunction of micro switch	Cool/Dry: compressor stops operation, while indoor fan operates; Heat: all loads stops operation.	1. The sliding door is blocked; 2. Malfunction of the photoelectric inspection panel of sliding door;
H4	System is abnormal	Cool/Dry: all loads stops operation except indoor fan; Heat: all loads stops operation.	See "High temperature prevention protection; high power; system is abnormal"
H7	Desynchronizing of compressor	Cool/Dry: compressor stops operation, while indoor fan operates; Heat: all loads stops operation.	See "Desynchronization diagnosis for compressor"
HC	PFC protection	Cool/Dry: compressor stops operation, while indoor fan operates; Heat: all loads stops operation.	1. The power grid quality is bad; AC input voltage fluctuates sharply; 2. Power plug of air conditioner or wiring board or reactor is not connected reliably; 3. Indoor and outdoor heat exchanger is too dirty, or air inlet/outlet is blocked; 4. Main board of outdoor unit is damaged.
HE	Demagnetization protection of compressor	Cool: compressor and outdoor fan stop operation; Heat: compressor and outdoor fan stop operation at first; about 1min later, indoor fan stops operation.	1. The main board of outdoor unit is damaged; 2. Compressor is damaged;
UF	Communication malfunction between indoor unit and inspection board	Normal operation	1. Poor connection between the indoor unit and the inspection board. 2. The main board of indoor unit is damaged; 3. The inspection board is damaged;
L1	Malfunction of humidity sensor	Compressor, outdoor fan and indoor fan stop operation;	The inspection board is damaged.
L9	High power protection	Cool: compressor and outdoor fan stops operation, while indoor fan operates.	See "High temperature prevention protection; high power; system is abnormal"
Lc	Start-up failed	Cool/Dry: compressor stops, while indoor fan operates; Heat: all loads stops operation.	See "Malfunction diagnosis for failure startup"
Ld	Lost phase	Cool: compressor and outdoor fan stop operation; Heat: compressor and outdoor fan stop operation at first; about 1min later, indoor fan stops operation.	1. The main board of outdoor unit is damaged; 2. The compressor is damaged; 3. The connection wire of compressor is not connected well.
PS	Over-phase current protection of compressor	Cool/Dry: compressor stops operation, while indoor fan operates; Heat: all loads stops operation.	See "Overload protection of compressor , High discharge temperature protection of compressor"

<b>Error code</b>	<b>Malfunction name</b>	<b>AC status</b>	<b>Possible causes</b>
<b>OE</b>	Undefined outdoor unit error	Cool: compressor and outdoor fan stops operation, while indoor fan operates; Heat: compressor, outdoor fan and indoor fan stop operation.	1. Outdoor ambient temperature exceeds the operation range of unit (eg: less than -20°C or more than 60°C for cooling; more than 30°C for heating); 2. Are wires of compressor not connected tightly? 3. Failure startup of compressor? 4. Is compressor damaged? 5. Is main board damaged?
<b>PE</b>	Communication malfunction between the drive board and the main board	Cool: compressor and outdoor fan stops operation; Heat: compressor and outdoor fan stop at first; about 1min later, indoor fan stops operation;	1. The drive board is damaged; 2. The main board of outdoor unit is damaged; 3. The drive board and the main board is not connected well.
<b>PE</b>	Circuit malfunction of module temperature sensor	Cool/Dry: compressor stops operation, while indoor fan operates; Heat: all loads stops operation.	Replace outdoor control board
<b>PE</b>	Module overheating protection	Cool: compressor stops operation, while indoor fan operates; Heat: all loads stops operation.	1. Air inlet / air outlet of outdoor unit are blocked by filth or dirt; 2. Condenser of outdoor unit is blocked by filth or dirt; 3. IPM screw of main board is not tightened; 4. Main board of outdoor unit is damaged;
<b>PE</b>	Malfunction of ambient temperature sensor of drive board	Cool: compressor, outdoor fan and indoor fan stop operation; Heat: compressor and outdoor fan stop operation at first; about 1min later, indoor fan stops operation.	1. The ambient temperature sensor of the drive board is not connected well; 2. Malfunction of the ambient temperature sensor of drive board.
<b>PH</b>	DC bus voltage is too high	Cool/Dry: compressor stops operation, while indoor fan operates; Heat: all loads stops operation.	1. Measure the voltage between position L and position N on the wiring board (XT). If it's higher than 265 VAC, please turn on the unit until the power voltage is decreased to the normal range; 2. If the AC input is normal, please replace the outdoor control board.
<b>PL</b>	DC bus voltage is too low	Cool/Dry: compressor stops operation, while indoor fan operates; Heat: all loads stops operation.	1. Measure the voltage between position L and position N on the wiring board (XT). If it's lower than 150 VAC, please turn on the unit until the power voltage is increased to the normal range; 2. If the AC input is normal, please replace the outdoor control board.
<b>PU</b>	Charging malfunction of capacitor	Cool/Dry: compressor stops operation, while indoor fan operates; Heat: all loads stops operation.	See "Charging malfunction of capacitor"
<b>RF</b>	Malfunction of RF module	Cool: compressor and outdoor fan stop operation; Heat: compressor and outdoor fan stop operation at first; about 1min later, indoor fan stops operation.	1. The connection wire of RF module is not connected well. 2. Malfunction of RF module;
<b>U1</b>	Phase current detection circuit malfunction of	Cool: compressor and outdoor fan stops operation, while indoor fan operates; Heat: compressor, outdoor fan and indoor fan stops operation.	The control board is damaged
<b>U2</b>	Lost phase protection of compressor	Cool: compressor and outdoor fan stop operation; Heat: compressor and outdoor fan stop operation at first; about 1min later, indoor fan stops operation.	1. The main board of outdoor unit is damaged; 2. The compressor is damaged; 3. The connection wire of compressor is not connected well.

Error code	Malfunction name	AC status	Possible causes
<b>U3</b>	DC bus voltage drop malfunction	Cool/Dry: compressor stops operation, while indoor fan operates; Heat: all loads stops operation.	The power voltage is unstable.
<b>U5</b>	Current detection malfunction of unit	Cool: compressor and outdoor fan stops operation, while indoor fan operates; Heat: compressor, outdoor fan and indoor fan stops operation.	1. Is the complete unit lacking of refrigerant? 2. There's malfunction for the circuit of control board of outdoor unit. Replace the control board of outdoor unit.
<b>U7</b>	4-way valve is abnormal	This malfunction occurs when the unit is heating. All loads stops operation.	1. Power voltage is lower than AC175V; 2. Wiring terminal of 4-way valve is loose or broken; 3. 4-way valve is damaged. Replace the 4-way valve.
<b>U8</b>	Malfunction of zero-crossing signal of indoor unit	Compressor, outdoor fan and indoor fan stop operation.	1. The power is abnormal; 2. Main board of indoor unit is damaged.
<b>U9</b>	Zero-crossing malfunction of outdoor unit	Cool: compressor stops operation, while indoor fan operates; Heat: all loads stops operation.	Replace the control board of outdoor unit.
<b>EA</b>	Refrigerant leak alarm		The air conditioner may have refrigerant leakage.
<b>E2</b>	Evaporator anti-freezing protection		Not error code, it is the status code in cooling process
<b>E9</b>	Anti cold air protection		Not error code, it is the status code in cooling process
	Defrosting	Heat indicator Flash once/10s	Not error code, it is the status code in cooling process

## Analysis or processing of some of the malfunction display:

### 1. Compressor discharge protection

Possible causes: shortage of refrigerant; blockage of air filter; poor ventilation or air flow short pass for condenser; the system has non-condensing gas (such as air, water etc.); blockage of capillary assy (including filter); leakage inside four-way valve causes incorrect operation; malfunction of compressor; malfunction of protection relay; malfunction of discharge sensor; outdoor temperature too high.

Processing method: refer to the malfunction analysis in the above section.

### 2. Low voltage overcurrent protection

Possible cause: Sudden drop of supply voltage.

3. Communication malfunction

Processing method: Check if communication signal cable is connected reliably.

### 4. Sensor open or short circuit

Processing method: Check whether sensor is normal, connected with the corresponding position on the controller and if damage of lead wire is found.

### 5. Compressor over load protection

Possible causes: insufficient or too much refrigerant; blockage of capillary and increase of suction temp.; improper running of compressor, burning in or stuck of bearing, damage of discharge valve; malfunction of protector.

Processing method: adjust refrigerant amount; replace the capillary; replace the compressor; use universal meter to check if the contactor of compress or is fine when it is not overheated, if not replace the protector.

### 6. System malfunction

i.e. overload protection. When tube temperature (Check the temperature of outdoor heat exchanger when cooling and check the temperature of indoor heat exchanger when heating) is too high, protection will be activated.

Possible causes: Outdoor temperature is too high when cooling; insufficient outdoor air circulation; refrigerant flow malfunction.

please refer to the malfunction analysis in the previous section for handling method .

### 7. IPM module protection

Processing method: Once the module malfunction happens, if it persists for a long time and can not be self canceled, cut off the power and turn off the unit, and then re-energize the unit again after about 10 min. After repeating the procedure for sever times, if the malfunction still exists, replace the module.

## 9.2 Procedure of Troubleshooting

### 1. Troubleshooting for jumper cap C5

Main check points:

- (1) jumper cap
- (2) control board of indoor unit

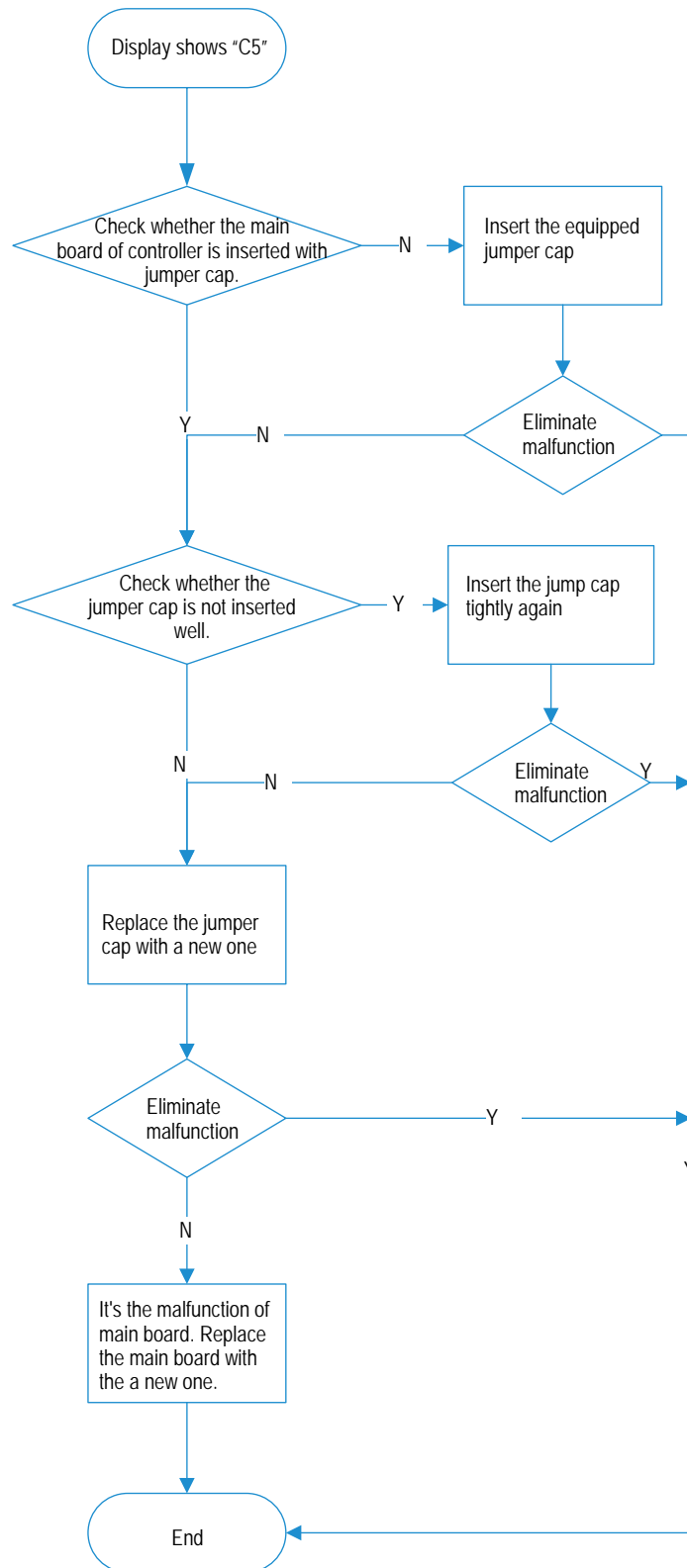

## 2. Communication malfunction E5

Main check points:

- (1) Connection wire between indoor unit and outdoor unit
- (2) Wiring inside the unit
- (3) Communication circuit of control board of indoor unit
- (4) Communication circuit of control board of outdoor unit

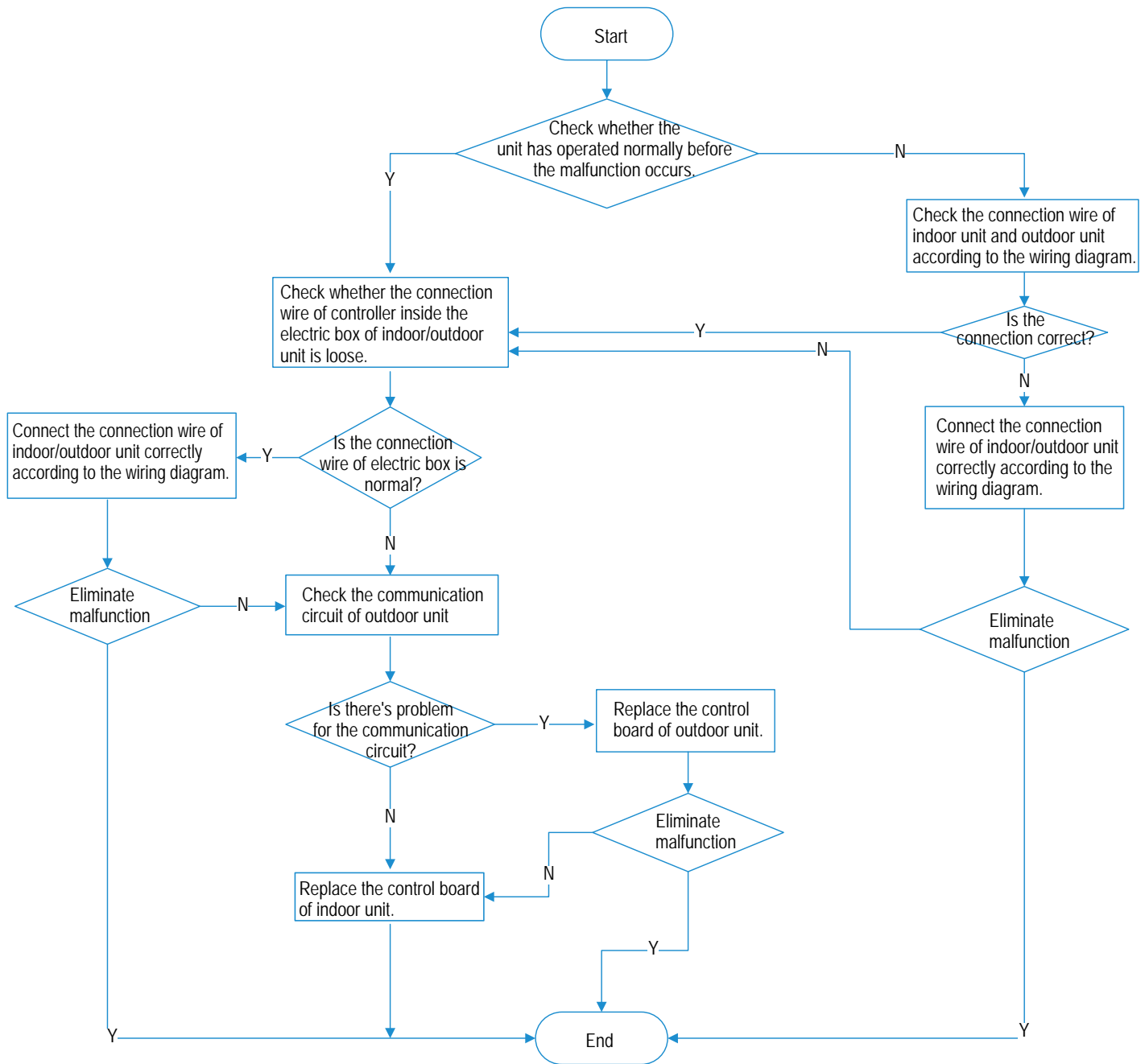

**Note:** method for checking the communication circuit of inverter split type and floor standing unit: cut off the communication wires of indoor/outdoor unit, and then measure the voltage between COM and N of the control board of outdoor unit (DC notch, about 56V)

### 3. IPM protection H5, over-phase current of compressor P5

Main check points:

- (1) compressor COMP terminal
- (2) power supply voltage
- (3) compressor
- (4) charging amount of refrigerant
- (5) air inlet and air outlet of indoor/outdoor unit

NOTE: The control board as below means the control board of outdoor unit.

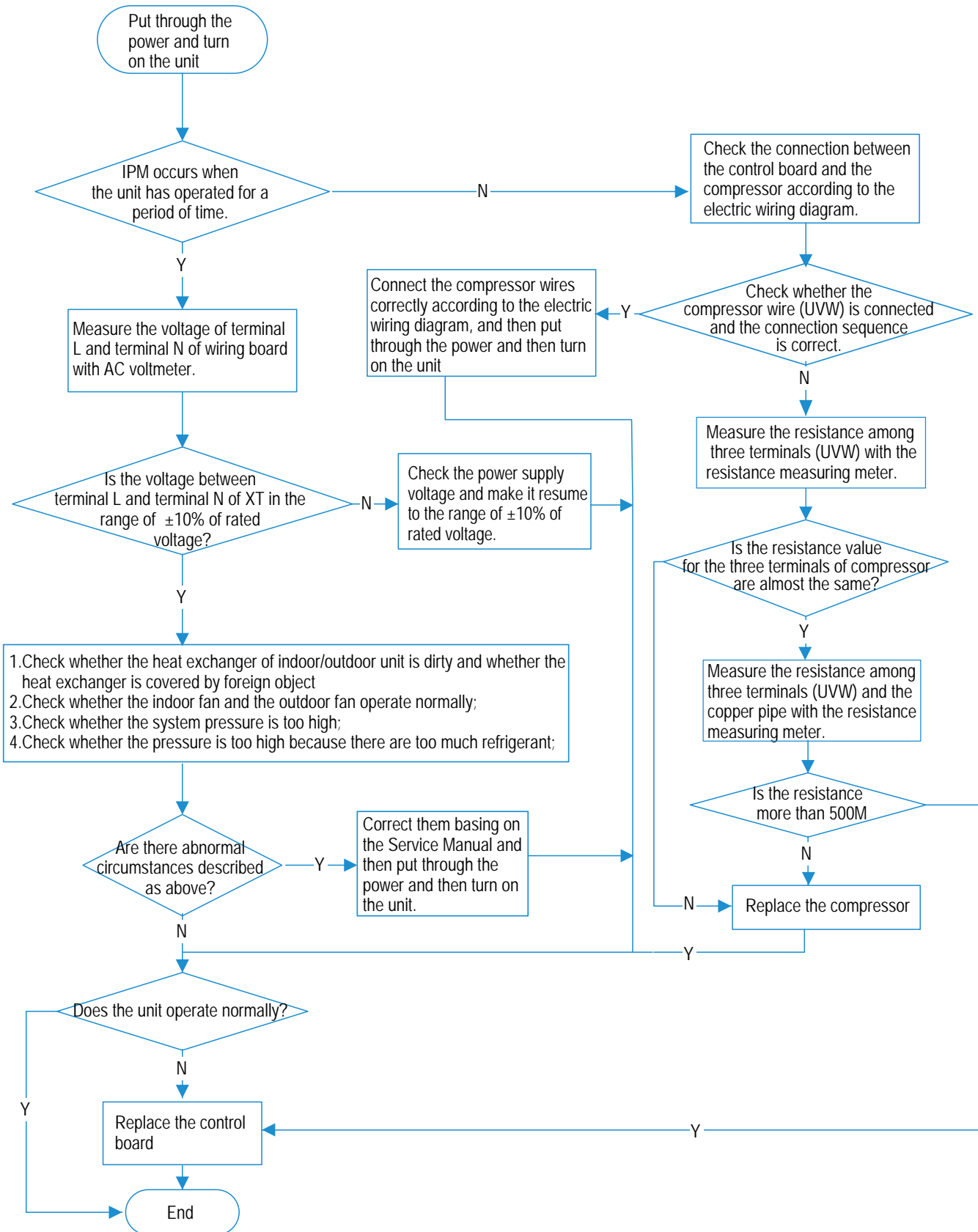

## 4. Overload protection of compressor H3, high discharge temperature, protection of compressor E4

Main check points:

- (1) electronic expansion valve
- (2) expansion valve terminal
- (3) charging amount of refrigerant
- (4) overload protector

NOTE: The control board as below means the control board of outdoor unit.

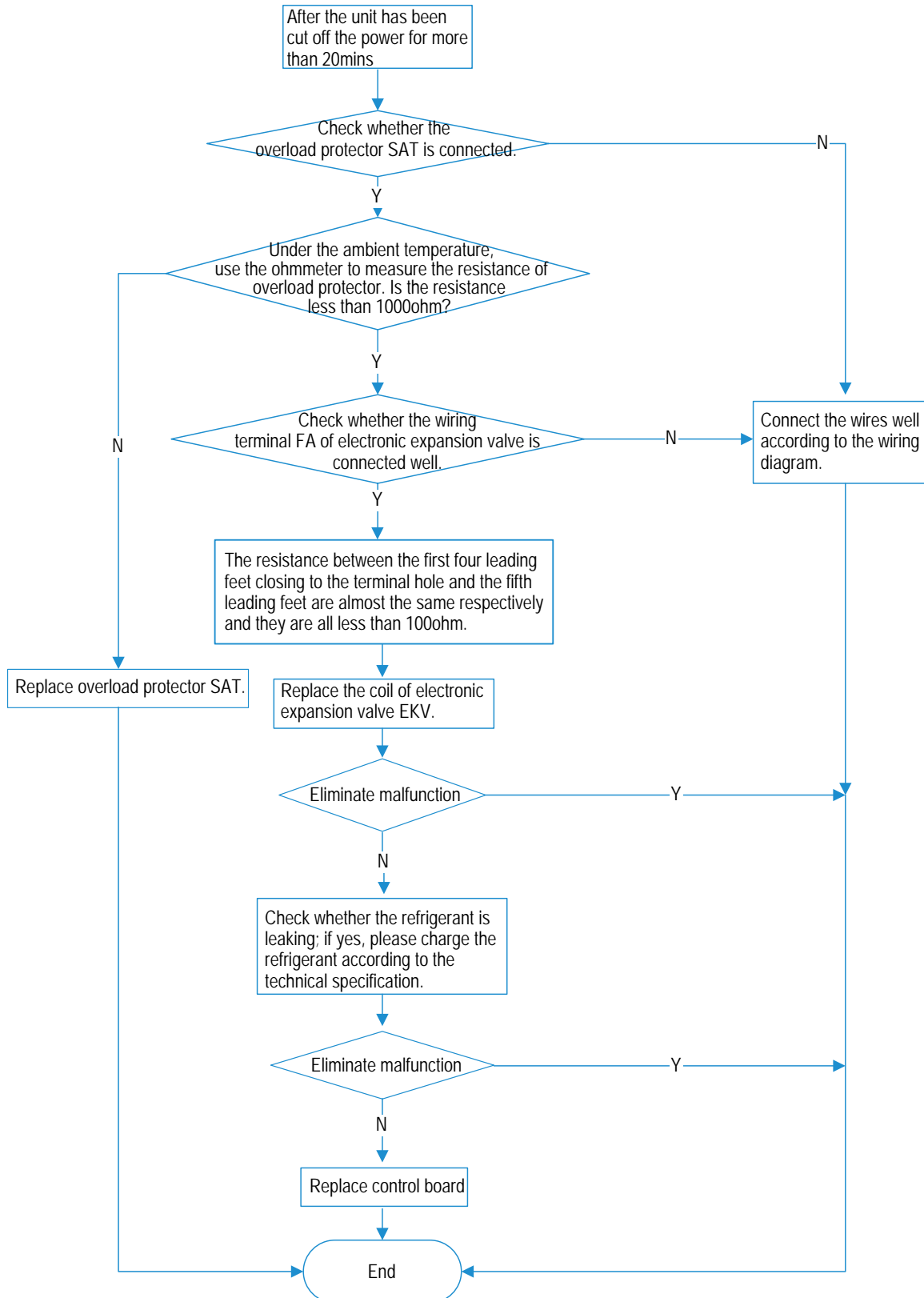

## 5. Troubleshooting for temperature sensor F1, F2, F3, F4, F5

Main check points:

(1) connection terminal (2) temperature sensor (3) main board

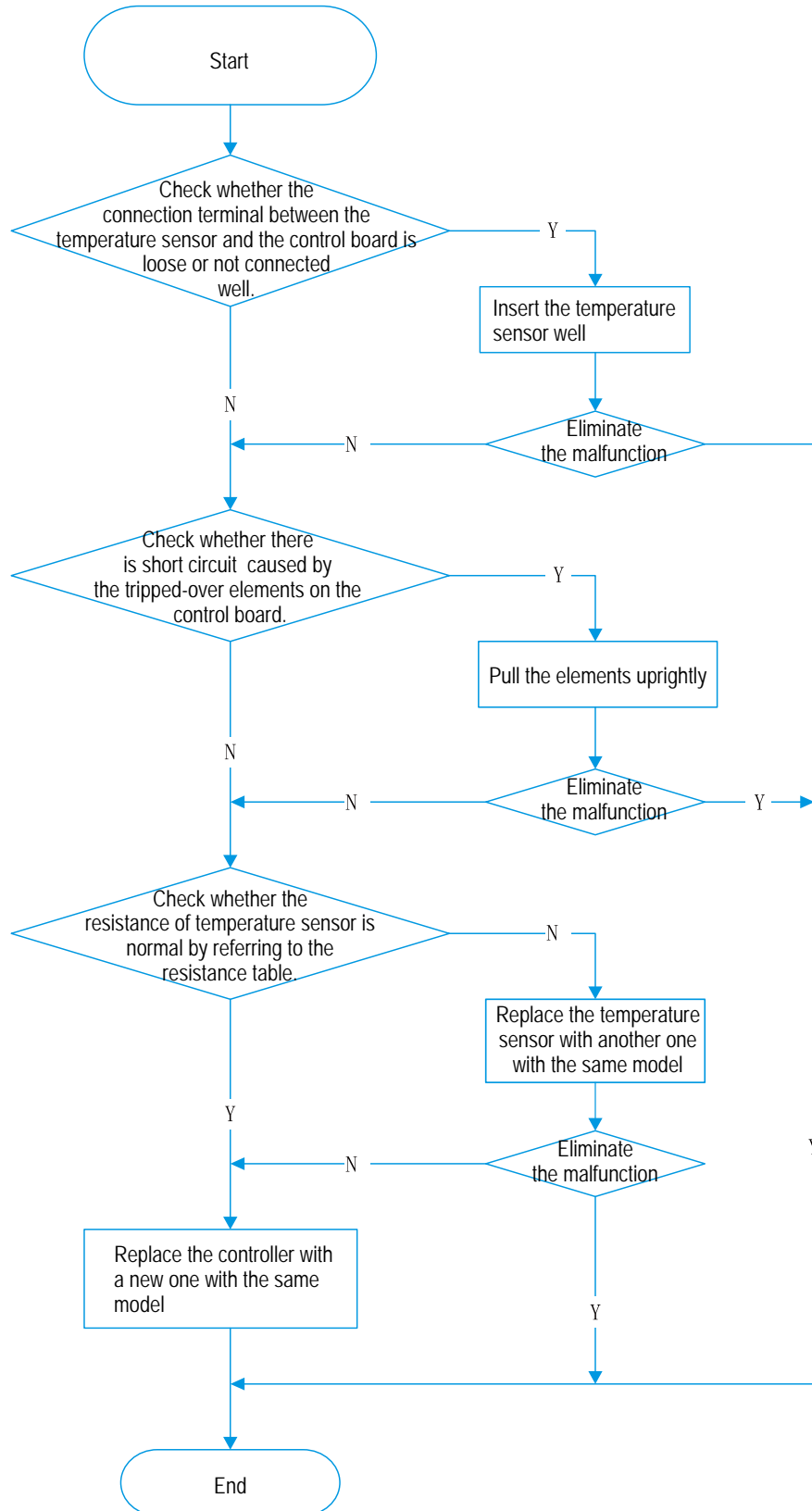



## 6.High temperature prevention protection E8; high power L9; system is abnormal H4

Main check points:

(1) outdoor temperature (2) fan (3)air inlet and air outlet of indoor/outdoor unit

NOTE:The control board as below means the control board of outdoor unit.

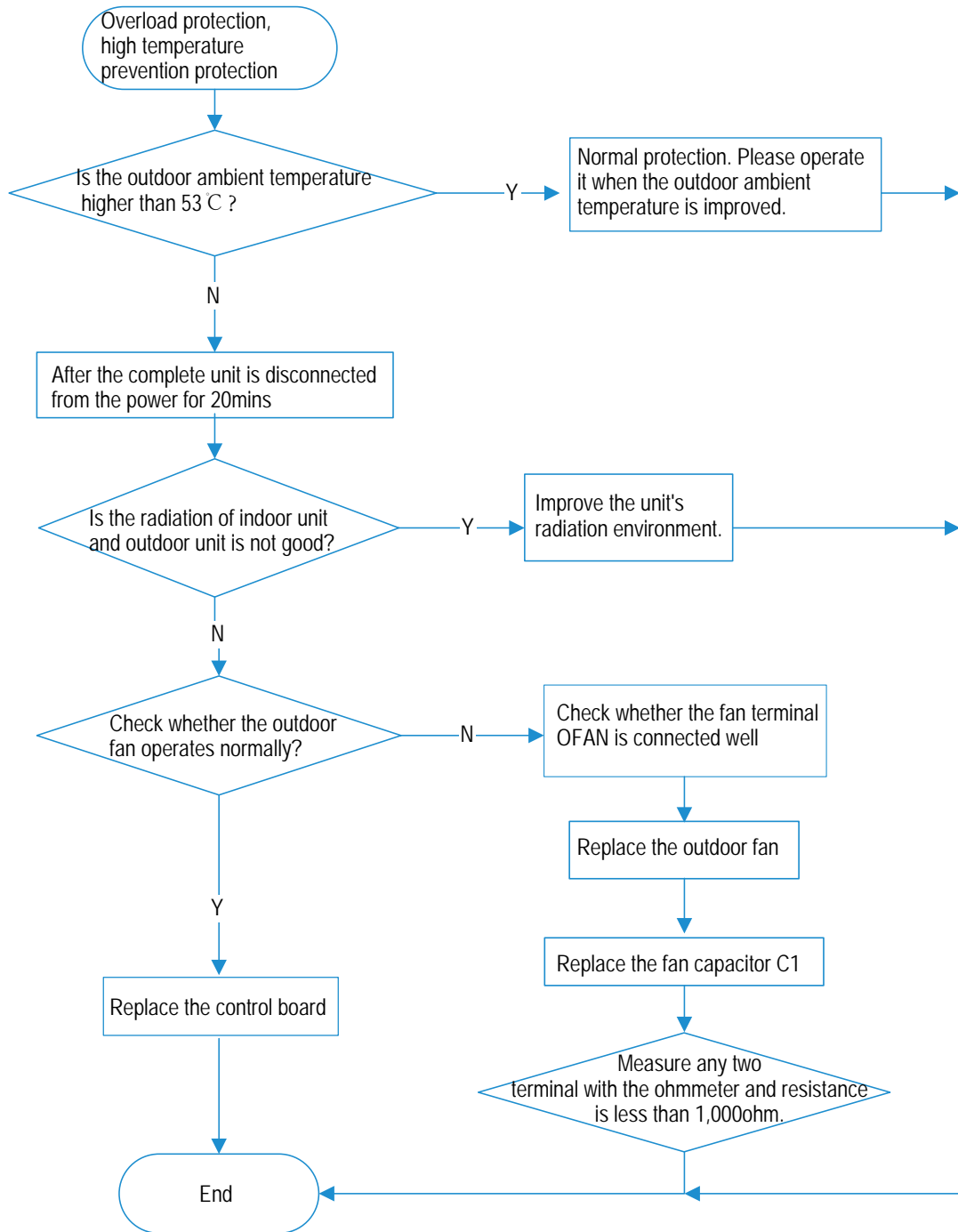

## 7.Desynchronization diagnosis for compressor H7

Main check point:

(1) system pressure (2) power supply voltage

NOTE:The control board as below means the control board of outdoor unit.

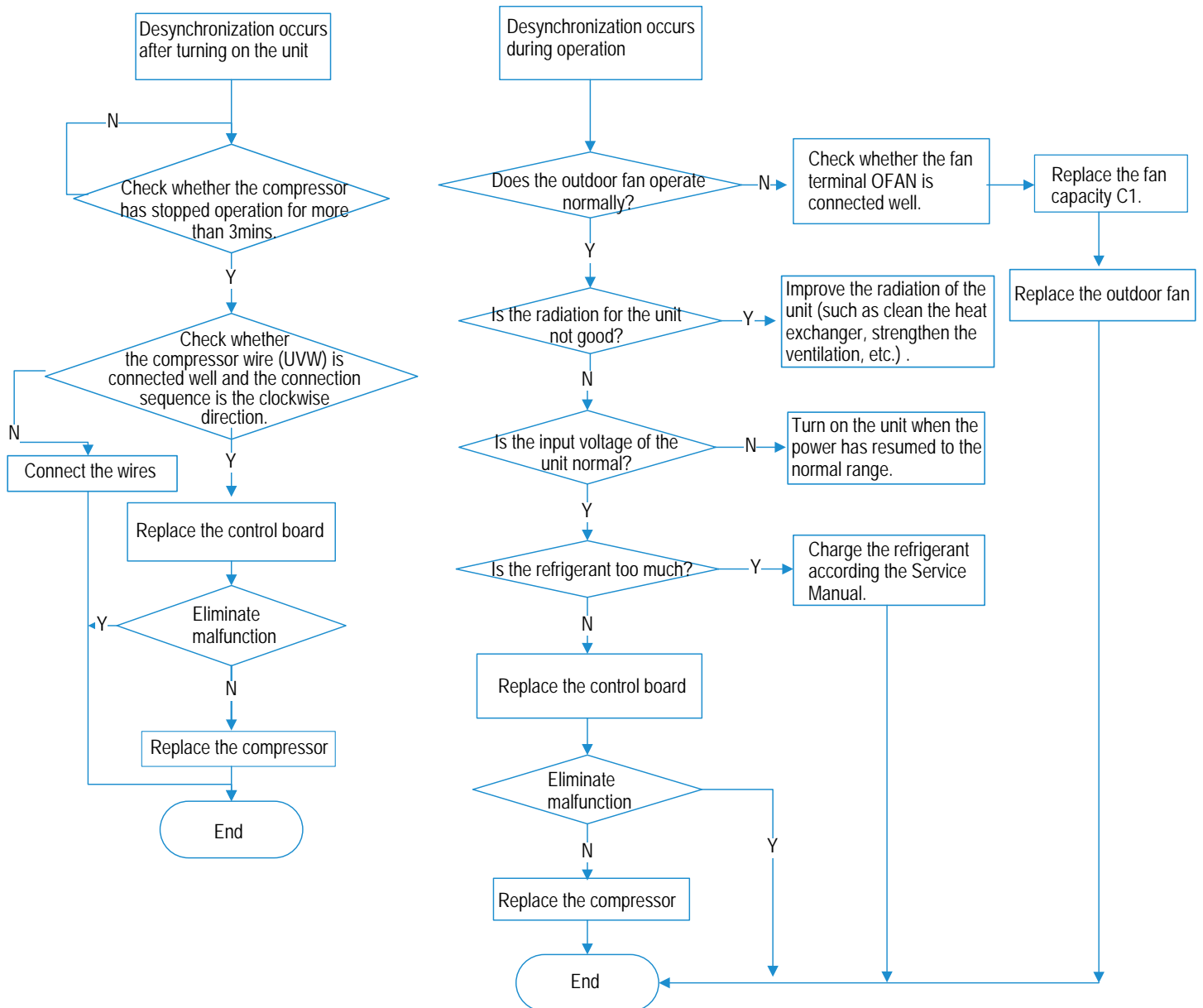

## 8. Malfunction diagnosis for failure startup Lc

Main check points:

(1) compressor wire (2) compressor (3) charging amount of refrigerant

NOTE: The control board as below means the control board of outdoor unit.

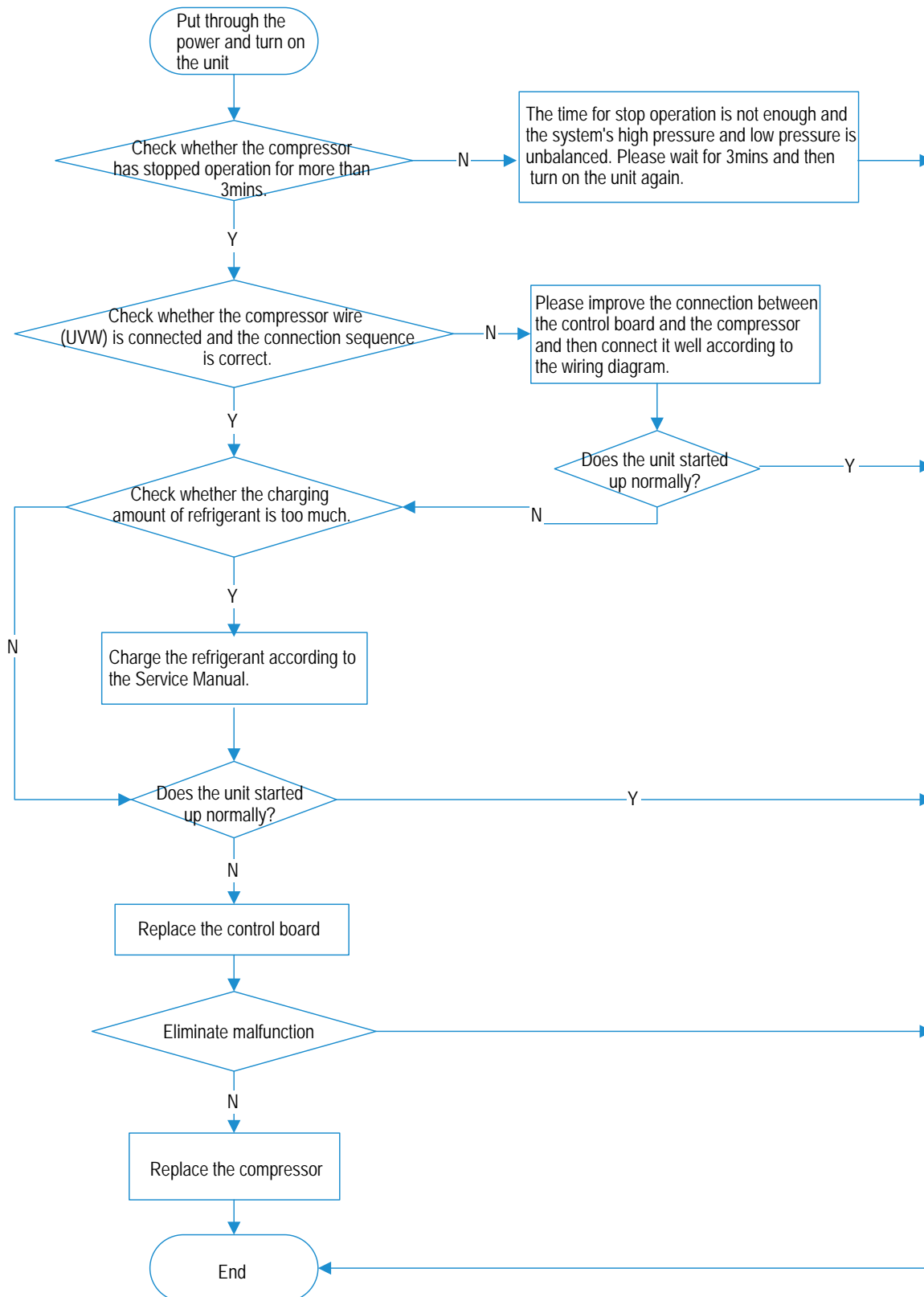

## 9. Charging malfunction of capacitor PU

Main check points: (1) wiring board XT (2) reactor

NOTE: The control board as below means the control board of outdoor unit.

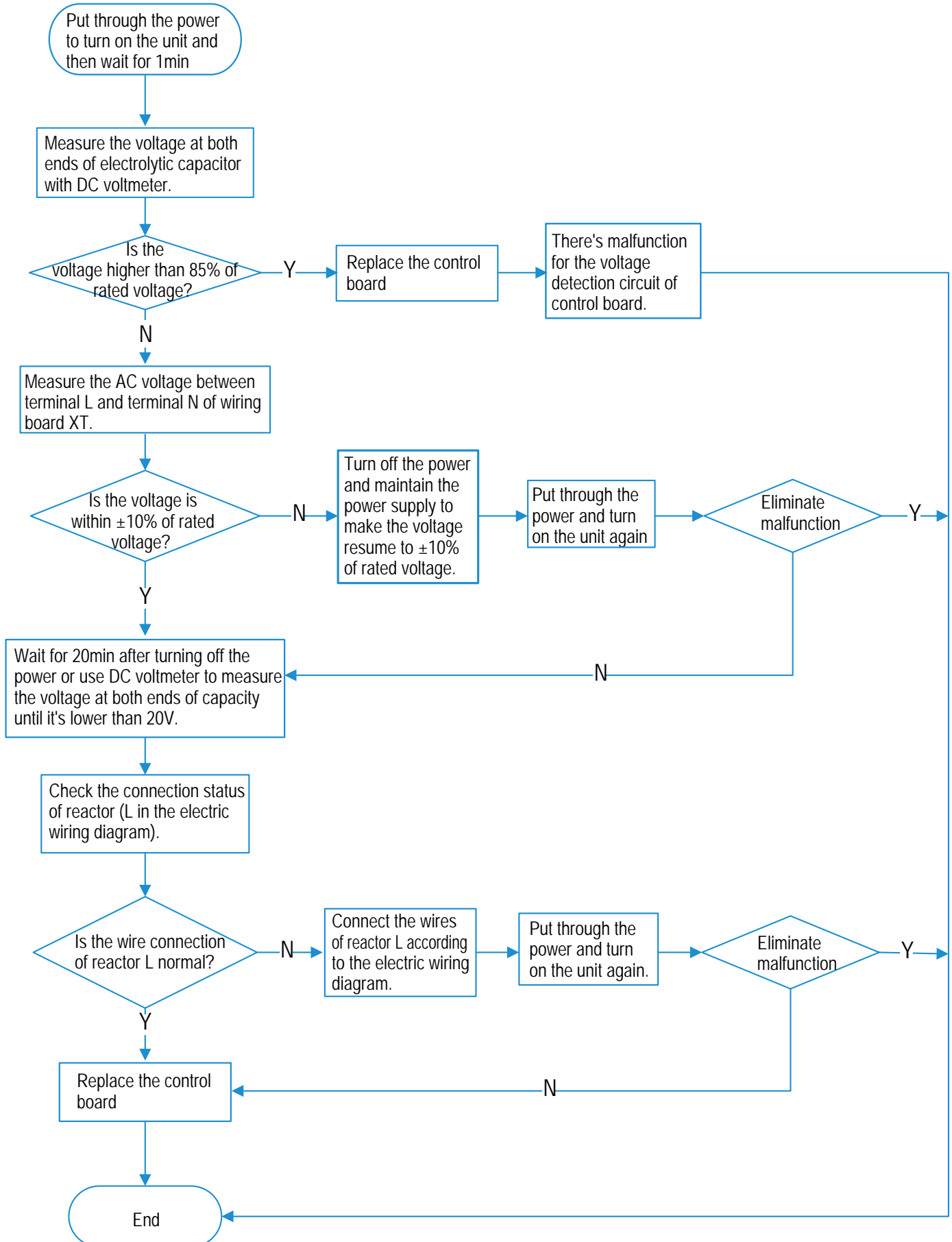

## 10. Troubleshooting-motor(indoor fan) doesn't operate H6

Main check points:

(1) connection terminal (2) motor (3) control board AP1 of indoor unit (4) blade

### 10.1 DC motor

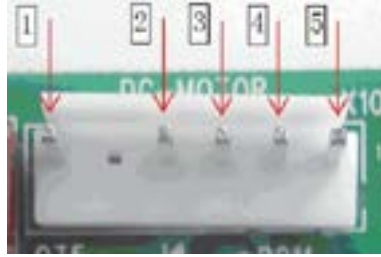
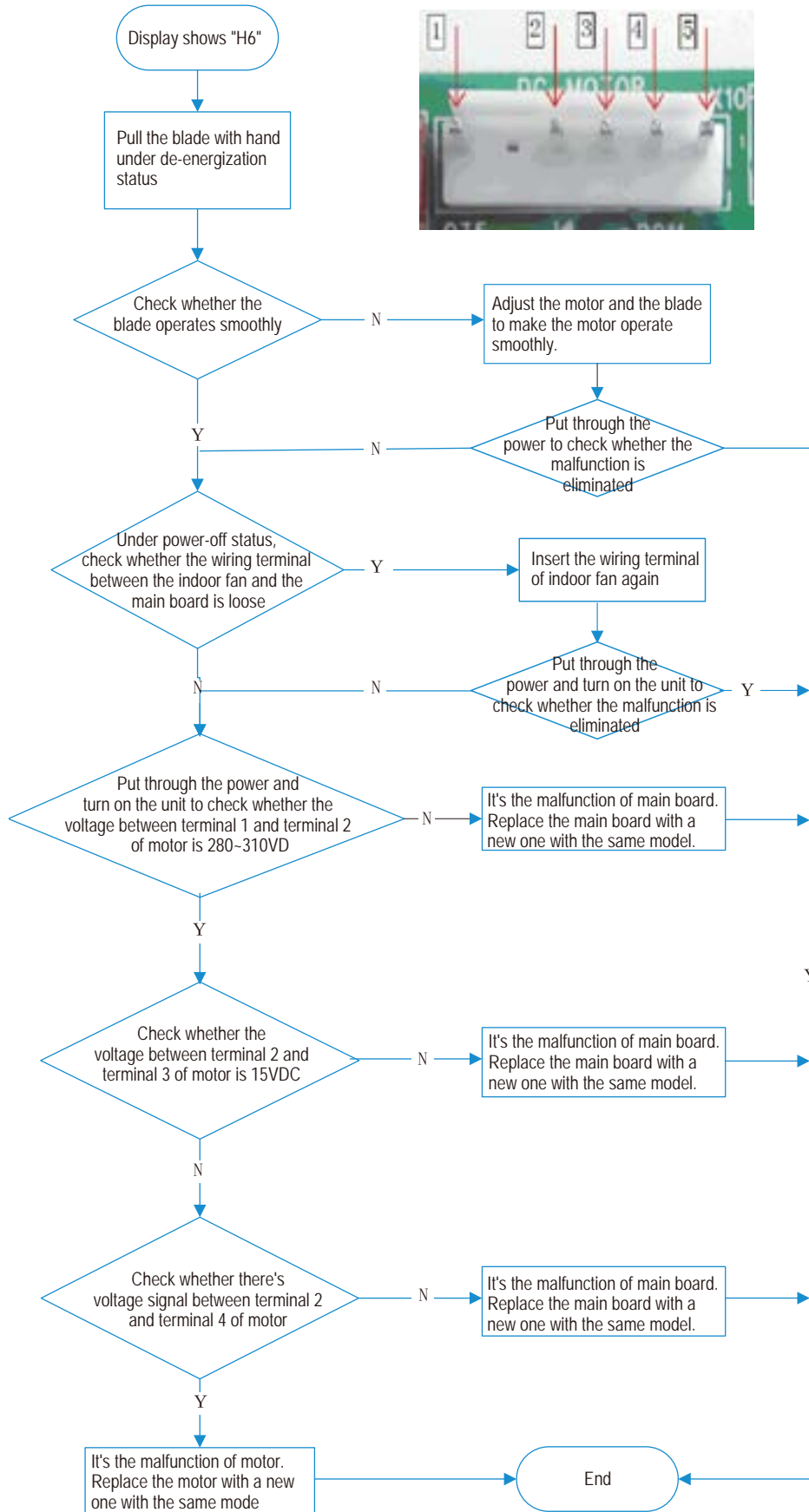

## 10.2 PG motor

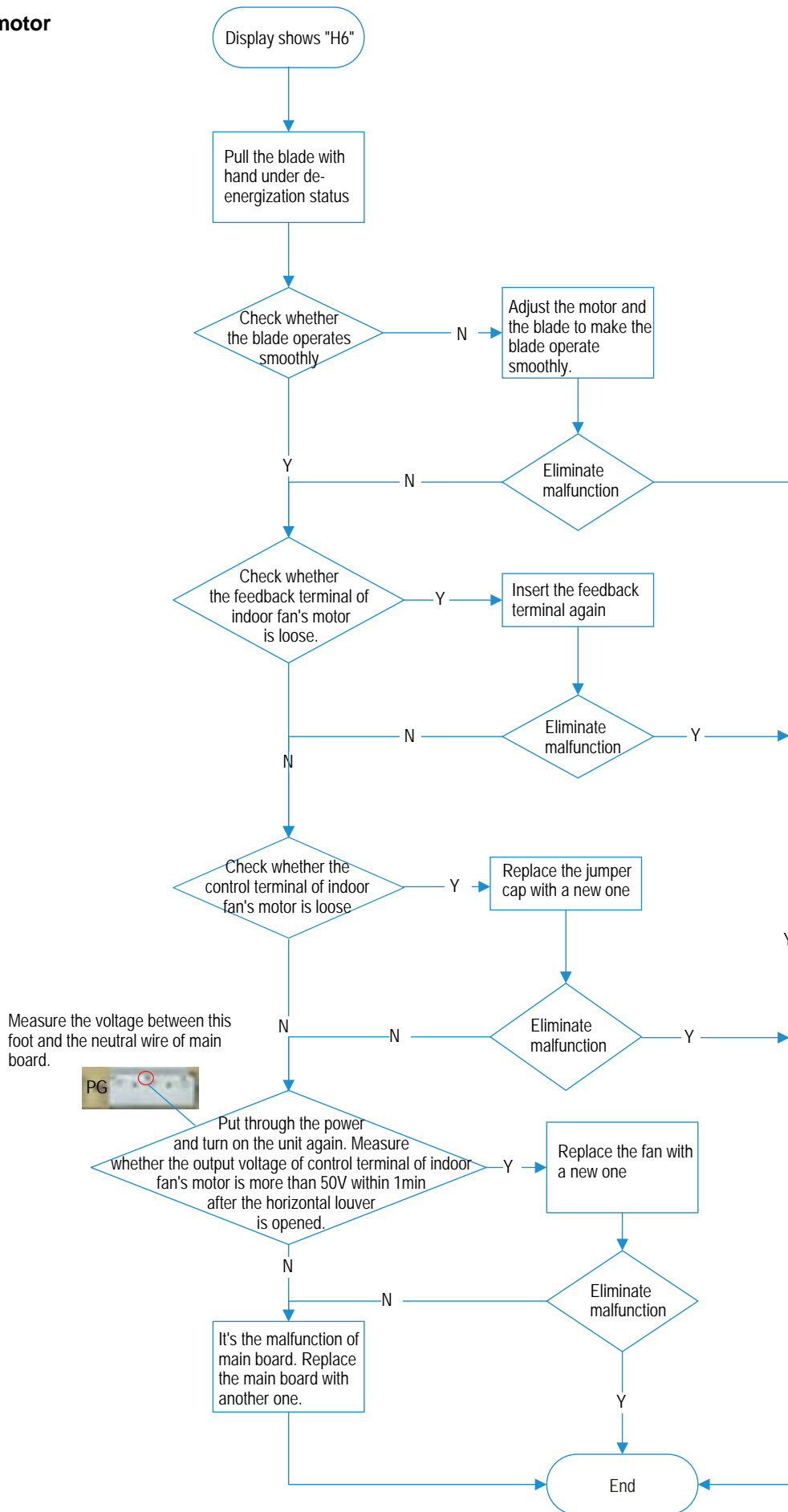

## 11. AC overcurrent protection E5

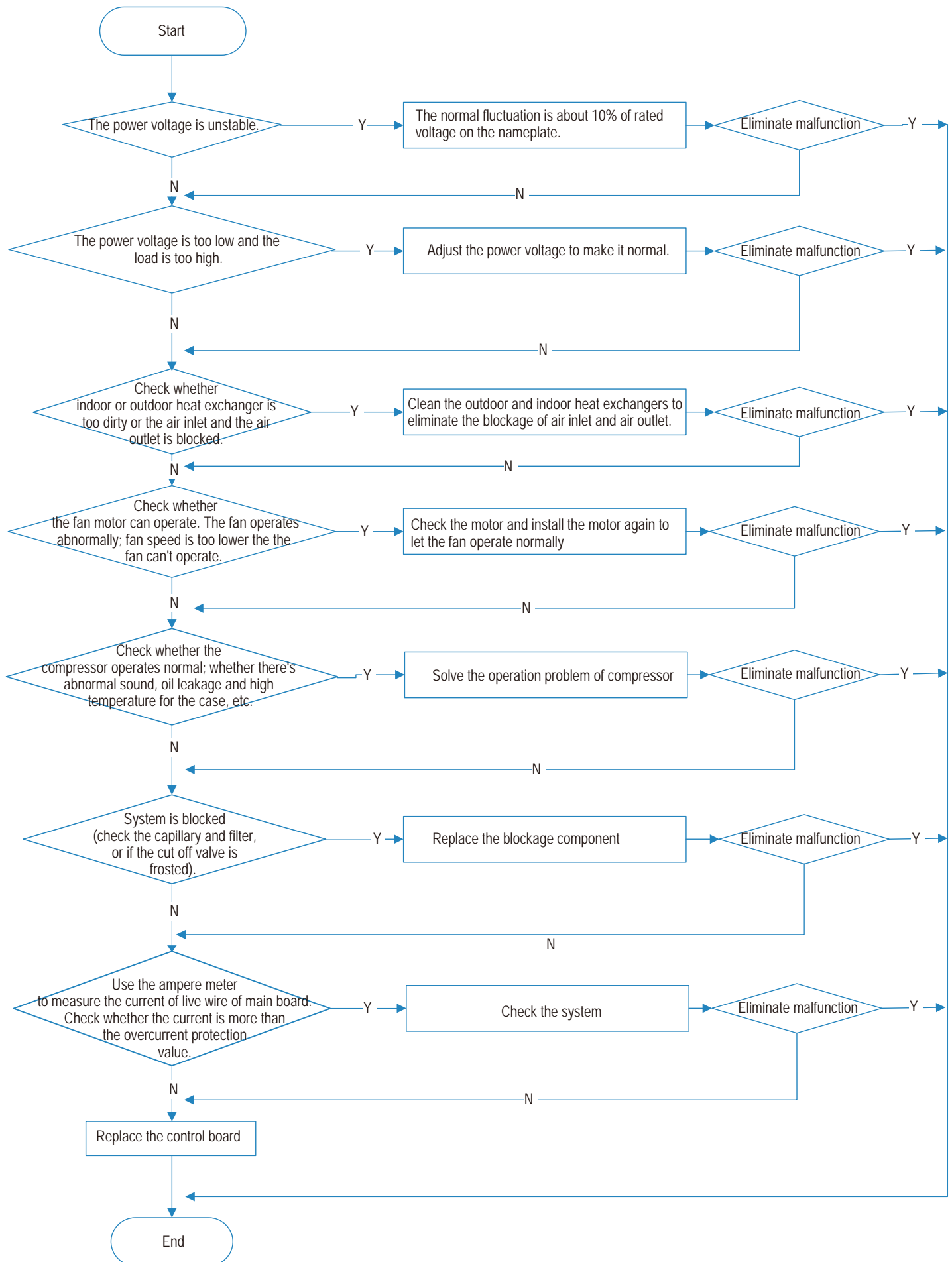

## 9.3 Troubleshooting for Normal Malfunction

### 1. Air Conditioner can't be Started Up

Possible Causes	Discriminating Method (Air conditioner Status)	Troubleshooting
No power supply, or poor connection for power plug	After energization, operation indicator isn't bright and the buzzer can't give out sound	Confirm whether it's due to power failure. If yes, wait for power recovery. If not, check power supply circuit and make sure the power plug is connected well.
Wrong wire connection between indoor unit and outdoor unit, or poor connection for wiring terminals	Under normal power supply circumstances, operation indicator isn't bright after energization	Check the circuit according to circuit diagram and connect wires correctly. Make sure all wiring terminals are connected firmly
Electric leakage for air conditioner	After energization, room circuit breaker trips off at once	Make sure the air conditioner is grounded reliably Make sure wires of air conditioner is connected correctly Check the wiring inside air conditioner. Check whether the insulation layer of power supply cord is damaged; if yes, place the power supply cord.
Model selection for air switch is improper	After energization, air switch trips off	Select proper air switch
Malfunction of remote controller	After energization, operation indicator is bright, while no display on remote controller or buttons have no action.	Replace batteries for remote controller Repair or replace remote controller

### 2. Poor Cooling (Heating) for Air Conditioner

Possible Causes	Discriminating Method (Air conditioner Status)	Troubleshooting
Set temperature is improper	Observe the set temperature on remote controller	Adjust the set temperature
Rotation speed of the IDU fan motor is set too low	Small wind blow	Set the fan speed at high or medium
Filter of indoor unit is blocked	Check the filter to see its blocked	Clean the filter
Installation position for indoor unit and outdoor unit is improper	Check whether the installation position is proper according to installation requirement for air conditioner	Adjust the installation position, and install the rainproof and sunproof for outdoor unit
Refrigerant is leaking	Discharged air temperature during cooling is higher than normal discharged wind temperature; Discharged air temperature during heating is lower than normal discharged wind temperature; Units pressure is much lower than regulated range	Find out the leakage causes and deal with it. Add refrigerant.
Malfunction of 4-way valve	Blow cold wind during heating	Replace the 4-way valve
Malfunction of capillary	Discharged air temperature during cooling is higher than normal discharged wind temperature; Discharged air temperature during heating is lower than normal discharged wind temperature; Unit pressure is much lower than regulated range. If refrigerant isn't leaking, part of capillary is blocked	Replace the capillary
Flow volume of valve is insufficient	The pressure of valves is much lower than that stated in the specification	Open the valve completely
Malfunction of horizontal louver	Horizontal louver can't swing	Refer to point 3 of maintenance method for details
Malfunction of the IDU fan motor	The IDU fan motor can't operate	Refer to troubleshooting for H6 for maintenance method in details
Malfunction of the ODU fan motor	The ODU fan motor can't operate	Refer to point 4 of maintenance method for details
Malfunction of compressor	Compressor can't operate	Refer to point 5 of maintenance method for details

### 3. Horizontal Louver can't Swing

Possible Causes	Discriminating Method (Air conditioner Status)	Troubleshooting
Wrong wire connection, or poor connection	Check the wiring status according to circuit diagram	Connect wires according to wiring diagram to make sure all wiring terminals are connected firmly
Stepping motor is damaged	Stepping motor can't operate	Repair or replace stepping motor
Main board is damaged	Others are all normal, while horizontal louver can't operate	Replace the main board with the same model



#### 4. ODU Fan Motor can't Operate

Possible causes	Discriminating method (air conditioner status)	Troubleshooting
Wrong wire connection, or poor connection	Check the wiring status according to circuit diagram	Connect wires according to wiring diagram to make sure all wiring terminals are connected firmly
Capacity of the ODU fan motor is damaged	Measure the capacity of fan capacitor with an universal meter and find that the capacity is out of the deviation range indicated on the nameplate of fan capacitor.	Replace the capacity of fan
Power voltage is a little low or high	Use universal meter to measure the power supply voltage. The voltage is a little high or low	Suggest to equip with voltage regulator
Motor of outdoor unit is damaged	When unit is on, cooling/heating performance is bad and ODU compressor generates a lot of noise and heat.	Change compressor oil and refrigerant. If no better, replace the compressor with a new one

#### 5. Compressor can't Operate

Possible causes	Discriminating method (air conditioner status)	Troubleshooting
Wrong wire connection, or poor connection	Check the wiring status according to circuit diagram	Connect wires according to wiring diagram to make sure all wiring terminals are connected firmly
Capacity of compressor is damaged	Measure the capacity of fan capacitor with an universal meter and find that the capacity is out of the deviation range indicated on the nameplate of fan capacitor.	Replace the compressor capacitor
Power voltage is a little low or high	Use universal meter to measure the power supply voltage. The voltage is a little high or low	Suggest to equip with voltage regulator
Coil of compressor is burnt out	Use universal meter to measure the resistance between compressor terminals and it's 0	Repair or replace compressor
Cylinder of compressor is blocked	Compressor can't operate	Repair or replace compressor

#### 6. Air Conditioner is Leaking

Possible causes	Discriminating method (air conditioner status)	Troubleshooting
Drain pipe is blocked	Water leaking from indoor unit	Eliminate the foreign objects inside the drain pipe
Drain pipe is broken	Water leaking from drain pipe	Replace drain pipe
Wrapping is not tight	Water leaking from the pipe connection place of indoor unit	Wrap it again and bundle it tightly

#### 7. Abnormal Sound and Vibration

Possible causes	Discriminating method (air conditioner status)	Troubleshooting
When turn on or turn off the unit, the panel and other parts will expand and there's abnormal sound	There's the sound of "PAPA"	Normal phenomenon. Abnormal sound will disappear after a few minutes.
When turn on or turn off the unit, there's abnormal sound due to flow of refrigerant inside air conditioner	Water-running sound can be heard	Normal phenomenon. Abnormal sound will disappear after a few minutes.
Foreign objects inside the indoor unit or there're parts touching together inside the indoor unit	There's abnormal sound fro indoor unit	Remove foreign objects. Adjust all parts position of indoor unit, tighten screws and stick damping plaster between connected parts
Foreign objects inside the outdoor unit or there're parts touching together inside the outdoor unit	There's abnormal sound fro outdoor unit	Remove foreign objects. Adjust all parts position of outdoor unit, tighten screws and stick damping plaster between connected parts
Short circuit inside the magnetic coil	During heating, the way valve has abnormal electromagnetic sound	Replace magnetic coil
Abnormal shake of compressor	Outdoor unit gives out abnormal sound	Adjust the support foot mat of compressor, tighten the bolts
Abnormal sound inside the compressor	Abnormal sound inside the compressor	If add too much refrigerant during maintenance, please reduce refrigerant properly. Replace compressor for other circumstances.

# 10. Exploded View and Parts List

## 10.1 Indoor Unit

LIV09HP115V1R32AH

LIV12HP115V1R32AH

LIV09HP230V1R32AH

LIV12HP230V1R32AH

ATC

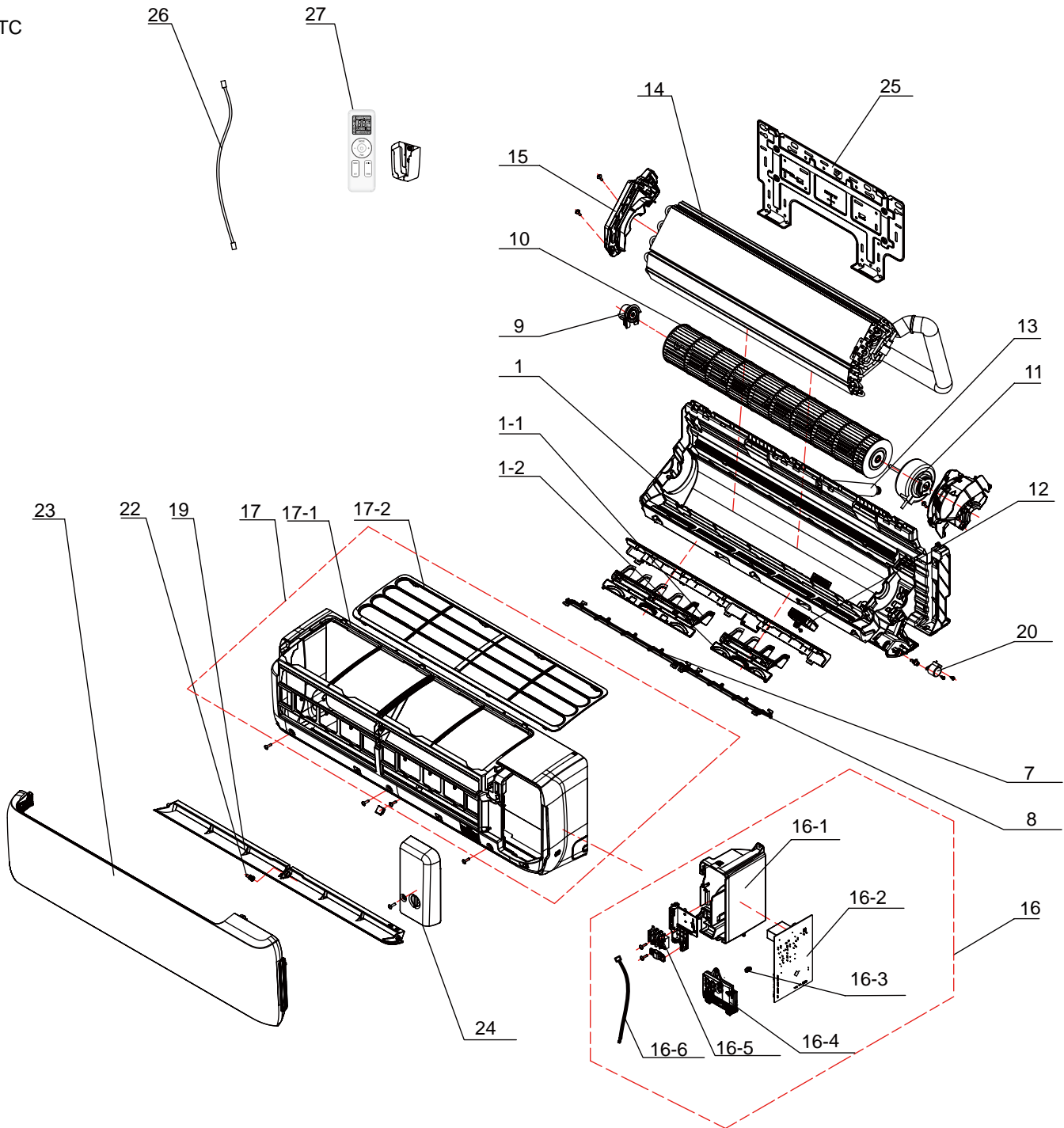

The component picture is only for reference; please refer to the actual product.

NO.	Description	NO.	Description
1	Rear Case Sub-Assy	16-3	Jumper
1-1	Air Louver(Left)	16-4	Display Board
1-2	Air Louver(Right)	16-5	Terminal Board
7	Rear Grill Sub-assy	16-6	Temperature Sensor
8	Rear Grill Sub-assy	17	Front Case Assy
9	Axile Bush Sub-assy	17-1	Front Case
10	Cross Flow Fan	17-4	Filter Sub-Assy
11	Fan Motor	19	Guide Louver
12	Plasmacluster Ion	20	Stepping Motor
13	Drainage Hose	22	Axile Bush
14	Evaporator Assy	23	Front Panel
15	Evaporator Support	24	Electric Box Cover
16	Electric Box Assy	25	Wall Mounting Frame
16-1	Electric Box	26	Power Cord
16-2	Main Board	27	Remote Controller

Some models may not contain some parts, please refer to the actual product.

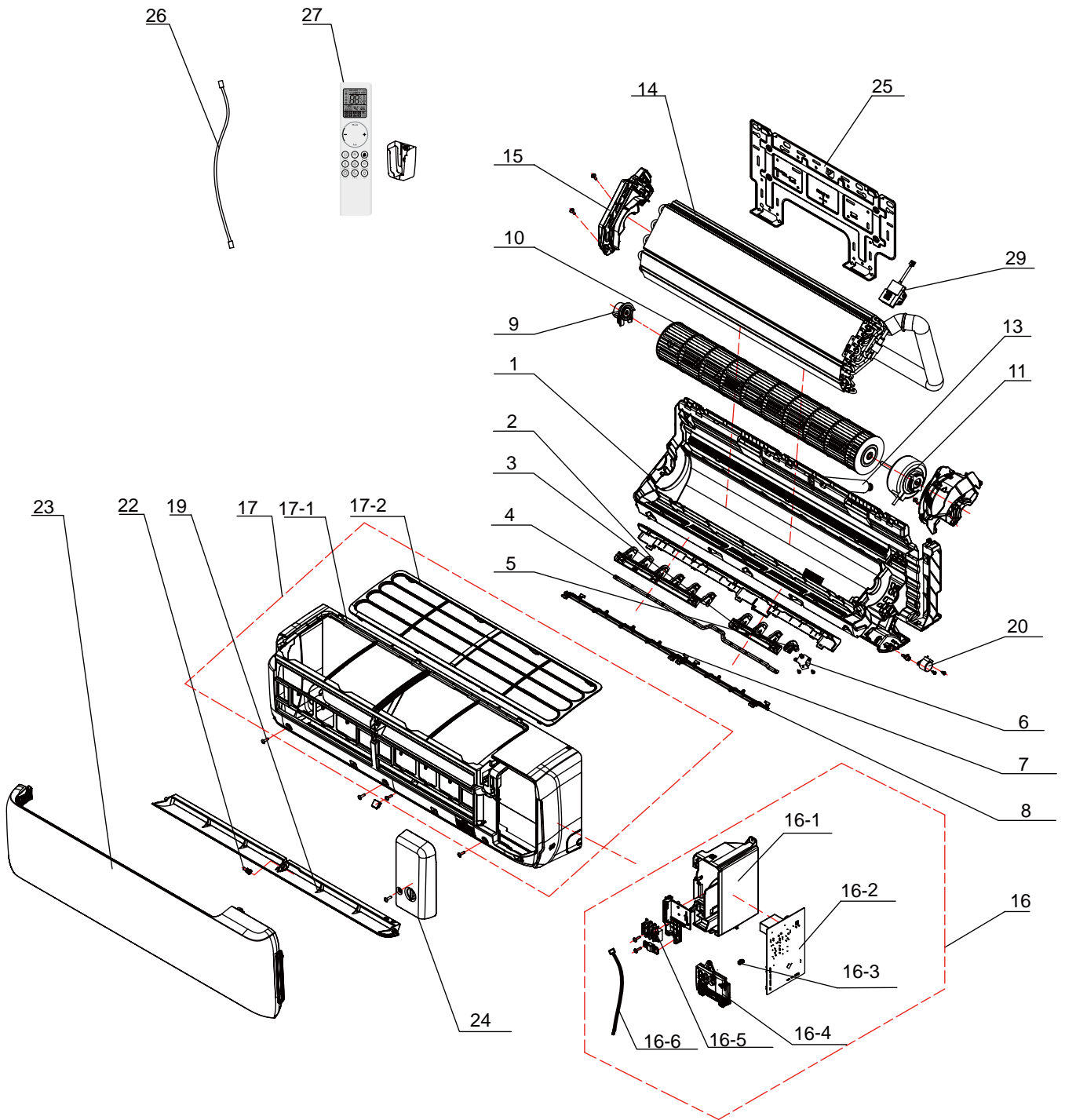

The component picture is only for reference; please refer to the actual product.

NO.	Description	NO.	Description
1	Rear Case Sub-Assy	16-3	Jumper
2	Air Louver(Left)	16-4	Display Board
3	Air Louver(Right)	16-5	Terminal Board
4	Swing Lever	16-6	Temperature Sensor
5	Air Louver (Auto)	17	Front Case Assy
6	Stepping Motor	17-1	Front Case
7	Rear Grill Sub-assy	17-4	Filter Sub-Assy
8	Rear Grill Sub-assy	19	Guide Louver
9	Axile Bush Sub-assy	20	Stepping Motor
10	Cross Flow Fan	22	Axile Bush
11	Fan Motor	23	Front Panel
13	Drainage Hose	24	Electric Box Cover
14	Evaporator Assy	25	Wall Mounting Frame
15	Evaporator Support	26	Power Cord
16	Electric Box Assy	27	Remote Controller
16-1	Electric Box	29	Gas Sensor
16-2	Main Board		

Some models may not contain some parts, please refer to the actual product.

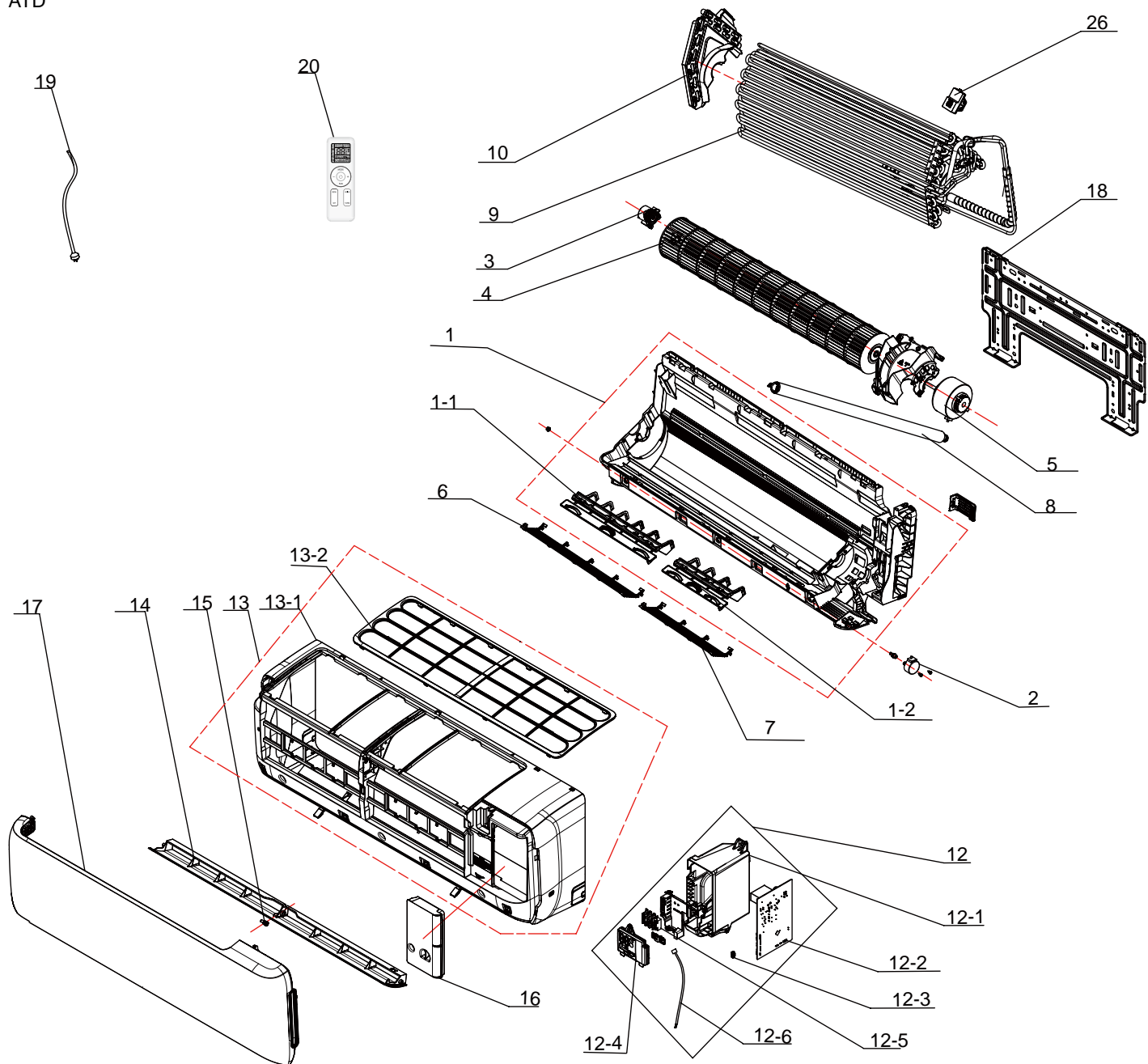

The component picture is only for reference; please refer to the actual product.

NO.	Description	NO.	Description
1	Rear Case Sub-Assy	12-3	Jumper
1-1	Air Louver	12-4	Display Board
1-2	Air Louver	12-5	Terminal Board
2	Stepping Motor	12-6	Temperature Sensor
3	Axile Bush Sub-assy	13	Front Case Assy
4	Cross Flow Fan	13-1	Front Case
5	Fan Motor	13-2	Filter Sub-Assy
6	Rear Grill Sub-assy	14	Guide Louver
7	Rear Grill Sub-assy	15	Axile Bush
8	Drainage Hose	16	Electric Box Cover
9	Evaporator Assy	17	Front Panel
10	Evaporator Support	18	Wall Mounting Frame
12	Electric Box Assy	19	Power Cord
12-1	Electric Box	20	Remote Controller
12-2	Main Board	26	Gas Sensor

Some models may not contain some parts, please refer to the actual product.

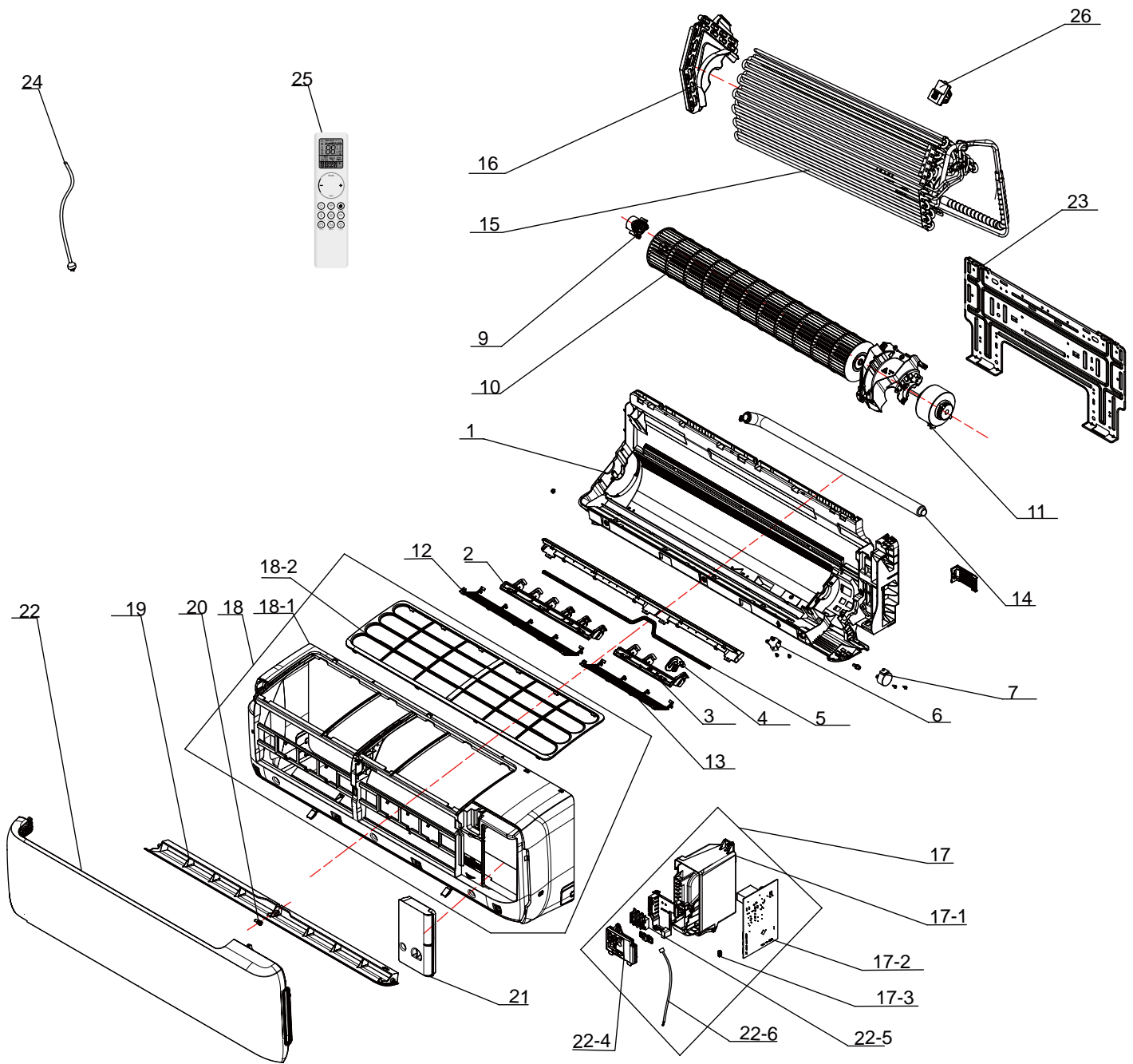

The component picture is only for reference; please refer to the actual product.



NO.	Description	NO.	Description
1	Rear Case Sub-Assy	17-1	Electric Box
2	Air Louver (Auto)	17-2	Main Board
3	Air Louver (Auto)	17-3	Jumper
4	Air Louver (Auto)	17-4	Display Board
5	Swing Lever	17-5	Terminal Board
6	Stepping Motor	17-6	Temperature Sensor
7	Stepping Motor	18	Front Case Assy
9	Axile Bush Sub-assy	18-1	Front Case
10	Cross Flow Fan	18-2	Filter Sub-Assy
11	Fan Motor	19	Guide Louver
12	Rear Grill Sub-assy	20	Axile Bush
13	Rear Grill Sub-assy	21	Electric Box Cover
14	Drainage Hose	22	Front Panel
15	Evaporator Assy	23	Wall Mounting Frame
16	Evaporator Support	25	Remote Controller
17	Electric Box Assy	26	Gas Sensor

Some models may not contain some parts, please refer to the actual product.

ATE

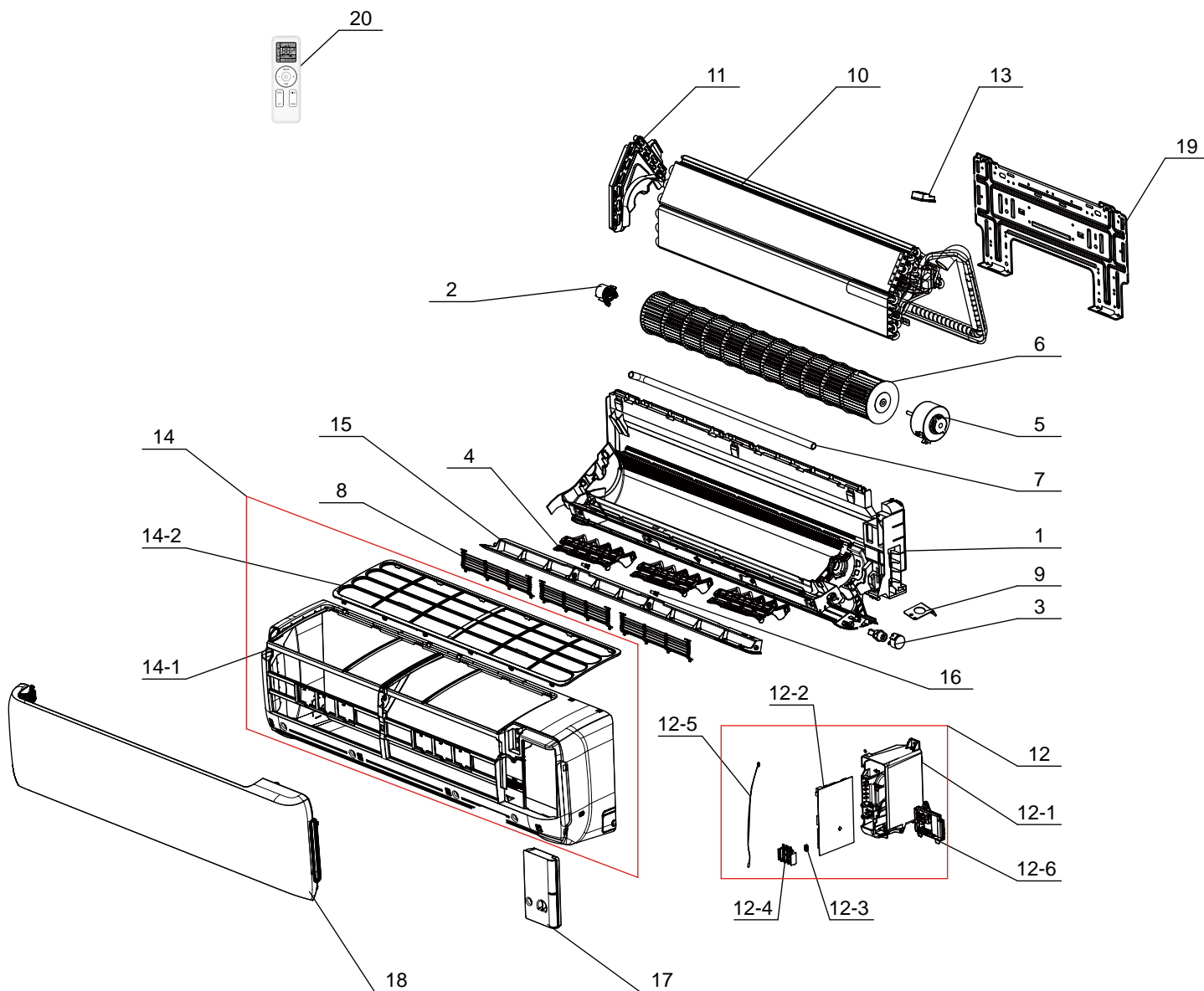

The component picture is only for reference; please refer to the actual product.

NO.	Description	NO.	Description
1	Rear Case Sub-Assy	12-3	Jumper
2	Axile Bush Sub-assy	12-4	Terminal Board
3	Stepping Motor	12-5	Temperature Sensor
4	Air Louver	12-6	Display Board
5	Brushless DC Motor	13	Gas Sensor
6	Cross Flow Fan	14	Front Case Sub-assy
7	Drainage Hose	14-1	Front Case
8	Rear Grill Sub-assy	14-2	Filter Sub-Assy
9	Cable Cross Plate	15	Guide Louver
10	Evaporator Assy	16	Axile Bush
11	Evaporator Support(D7)	17	Electric Box Cover
12	Electric Box Assy	18	Front Pane
12-1	Electric Box	19	Wall Mounting Frame
12-2	Main Board	20	Remote Controller

Some models may not contain some parts, please refer to the actual product.

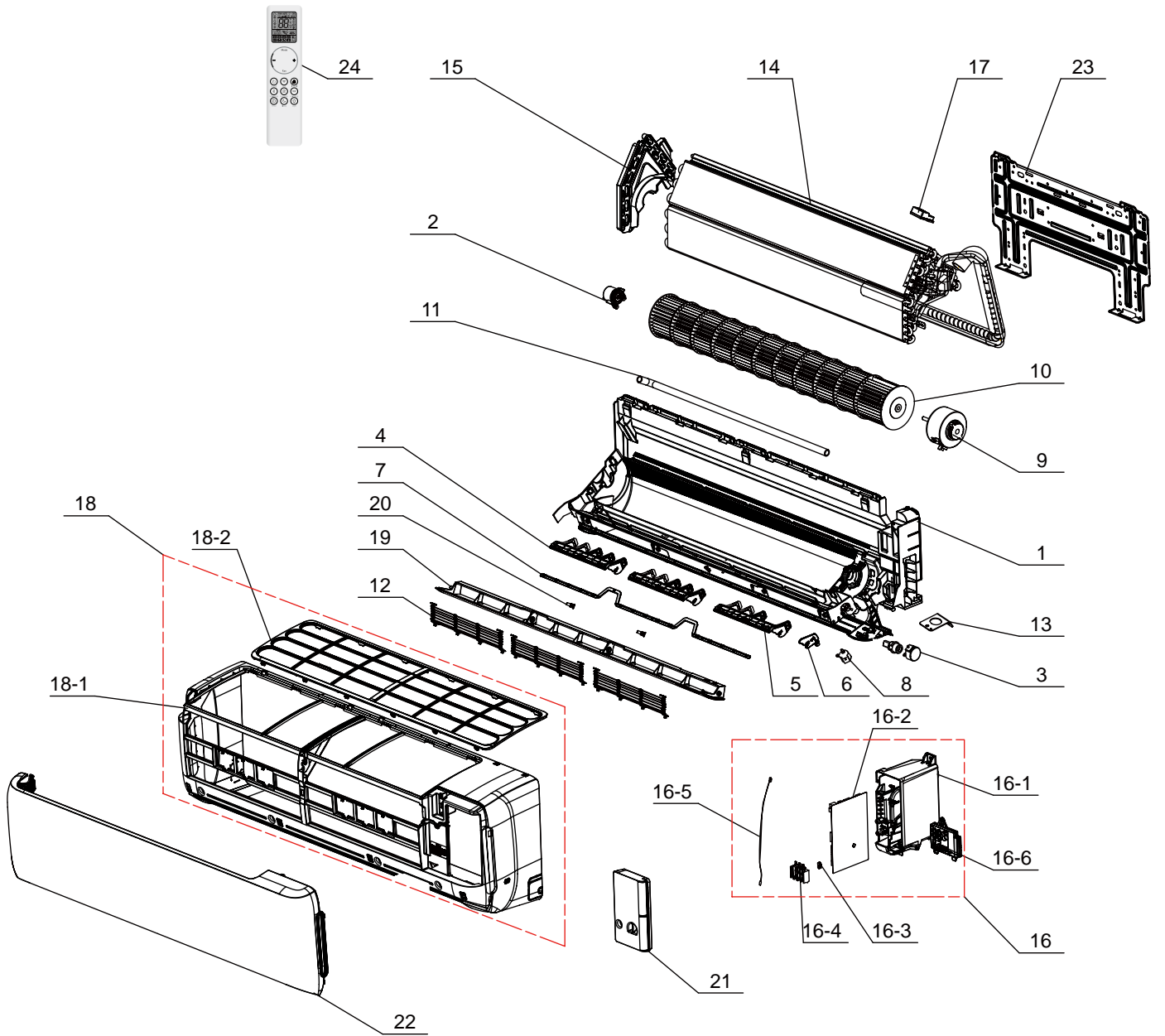

NO.	Description	NO.	Description
1	Rear Case Sub-Assy	16-1	Electric Box
2	Axile Bush Sub-assy	16-2	Main Board
3	Stepping Motor	16-3	Jumper
4	Air Louver 1	16-4	Terminal Board
5	Air Louver 1	16-5	Temperature Sensor
6	Air Louver	16-6	Display Board
7	Swing Lever	17	Gas Sensor
8	Stepping Motor	18	Front Case Sub-assy
9	Brushless DC Motor	18-1	Front Case
10	Cross Flow Fan	18-2	Filter Sub-Assy
11	Drainage Hose	19	Guide Louver
12	Rear Grill Sub-assy	20	Axile Bush
13	Cable Cross Plate	21	Electric Box Cover
14	Evaporator Assy	22	Front Pane
15	Evaporator Support(D7)	23	Wall Mounting Frame
16	Electric Box Assy	24	Remote Controller

Some models may not contain some parts, please refer to the actual product.

## 10.2 Outdoor Unit

GWC09ATCXB-A6DNA1B/O GWC09ATCXB-D6DNA1B/O GWC09ATCXB-D6DNA1B/O GWC09ATCXB-A6DNA1C/O  
 GWC09ATCXB-D6DNA1C/O GWC12ATCXB-A6DNA1A/O GWC12ATCXB-D6DNA1A/O

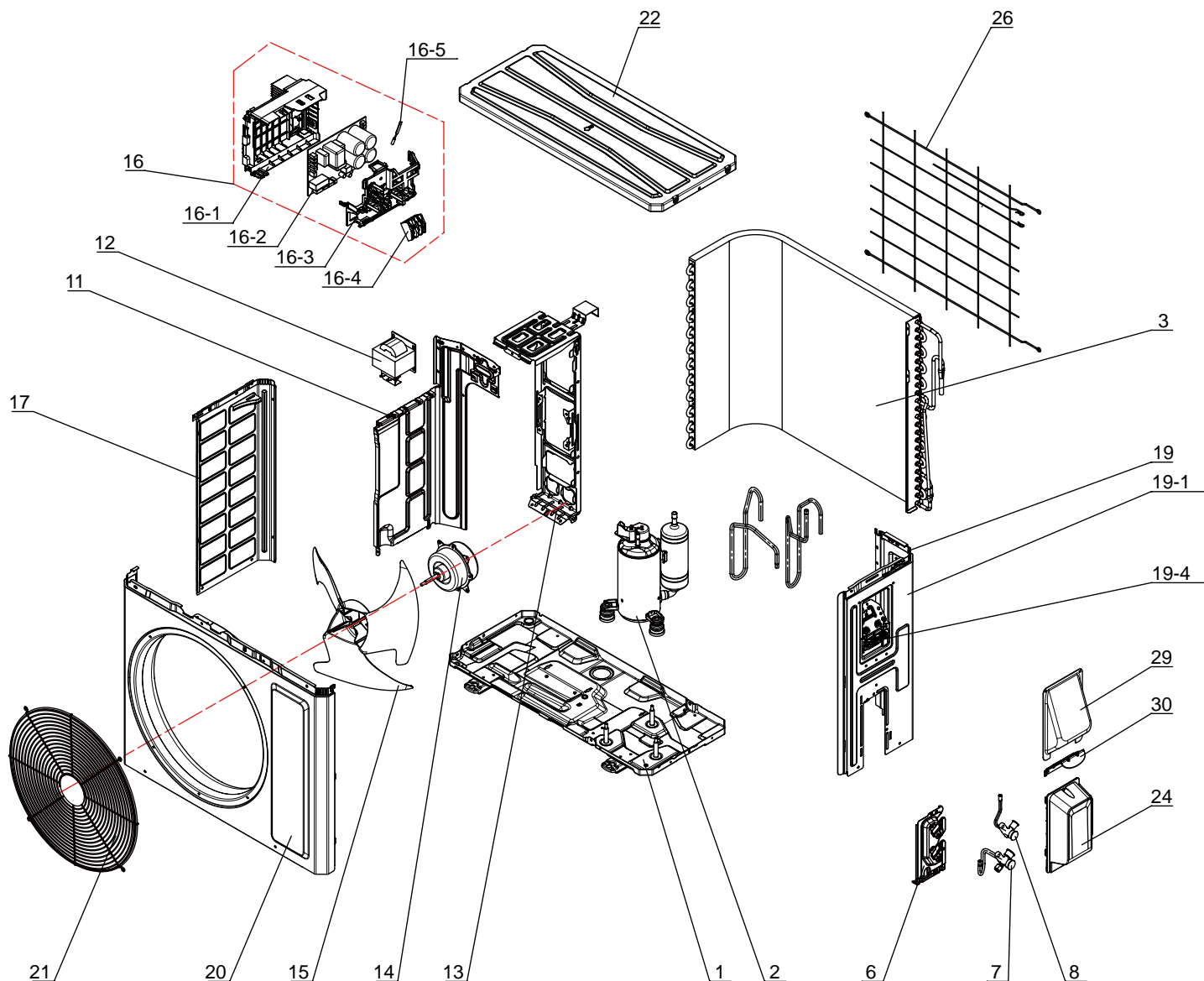

The component picture is only for reference; please refer to the actual product.

NO.	Description
1	Chassis Sub-assy
2	Compressor and Fittings
3	Condenser Assy
6	Valve Support
7	Cut-off valve (Big)
8	Cut-off valve (Small)
11	Clapboard
12	Reactor
13	Motor Support
14	Motor

NO.	Description
15	Axial Flow Fan
16	Electric Box Assy
16-1	Electric Box
16-2	Main Board
16-3	Electric Box Cover
16-4	Terminal Board
16-5	Temperature Sensor
17	Left Side Plate
19	Right Side Plate Assy
19-1	Right Side Plate

NO.	Description
19-4	Wire Clamp
20	Cabinet
21	Front Grill
22	Top Cover Assy
24	Valve Cover
26	Rear Grill
29	Cable Cross Plate
30	Cable Cross Plate

Some models may not contain some parts, please refer to the actual product.

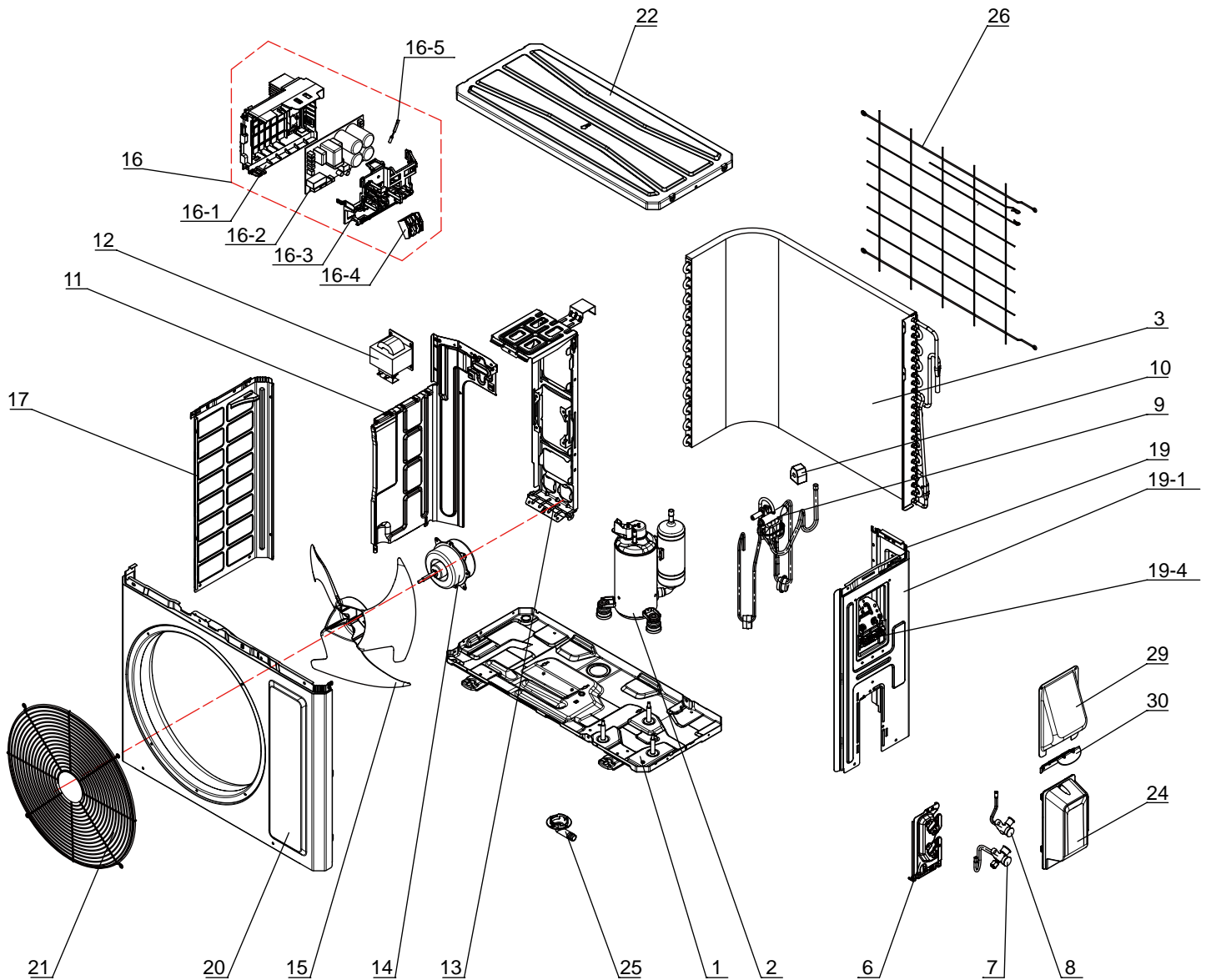

The component picture is only for reference; please refer to the actual product.

NO.	Description
1	Chassis Sub-assy
2	Compressor and Fittings
3	Condenser Assy
6	Valve Support
7	Cut-off valve (Big)
8	Cut-off valve (Small)
9	4-Way Valve Assy
10	Magnet Coil
11	Clapboard
12	Reactor
13	Motor Support

NO.	Description
14	Motor
15	Axial Flow Fan
16	Electric Box Assy
16-1	Electric Box
16-2	Main Board
16-3	Electric Box Cover
16-4	Terminal Board
16-5	Temperature Sensor
17	Left Side Plate
19	Right Side Plate Assy
19-1	Right Side Plate

NO.	Description
19-4	Wire Clamp
20	Cabinet
21	Front Grill
22	Top Cover Assy
24	Valve Cover
25	Drainage Joint
26	Rear Grill
29	Cable Cross Plate
30	Cable Cross Plate

Some models may not contain some parts, please refer to the actual product.

GWC12ATCXD-A6DNA1A/O GWC12ATCXD-D6DNA1A/O GWC18ATDXD-D6DNA1C/O

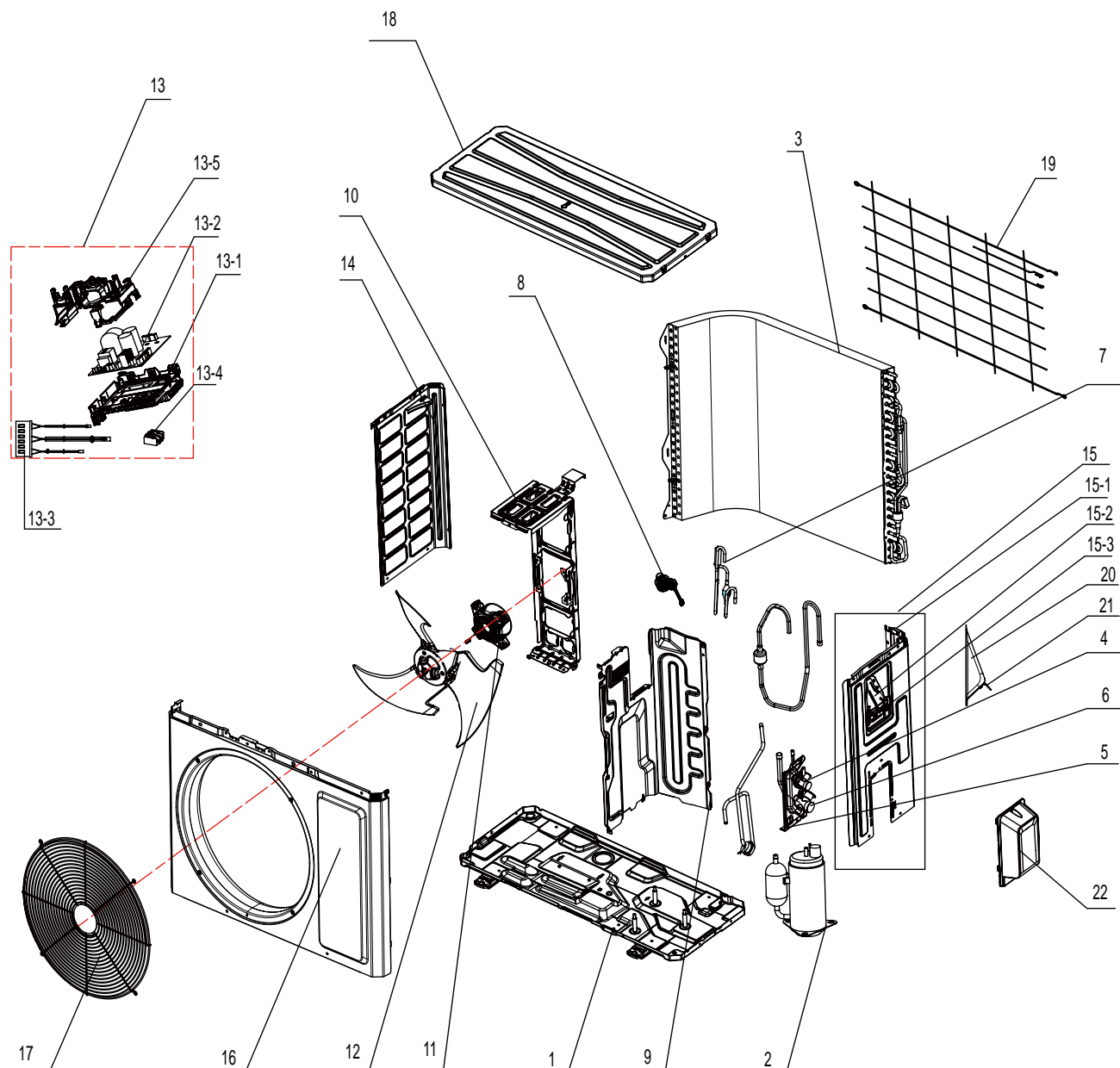

The component picture is only for reference; please refer to the actual product.

NO.	Description
1	Chassis Sub-assy
2	Compressor and Fittings
3	Condenser Assy
4	Cut-off valve small
5	Valve Support
6	Cut-off valve big
7	Electric Expansion Valve Sub-Assy
8	Electric Expansion Valve Fitting
9	Clapboard
10	Motor Support

NO.	Description
11	Fan Motor
12	Axial Flow Fan
13	Electric Box Assy
13-1	Electric Box
13-2	Main Board
13-3	Temperature Sensor
13-4	Terminal Board
13-5	Electric Box Cover
14	Left Side Plate
15	Right Side Plate Assy
15-1	Right Side Plate

NO.	Description
15-2	Earthing Plate Sub-assy
15-3	Wire Clamp
16	Cabinet
17	Front Grill(metal)
18	Top Cover Assy
19	Rear Grill
20	Cable Cross Plate
21	Cable Cross Plate 1
22	Valve Cover

Some models may not contain some parts, please refer to the actual product.



**GWH12ATCXD-A6DNA1B/O GWH12ATCXD-D6DNA1B/O**

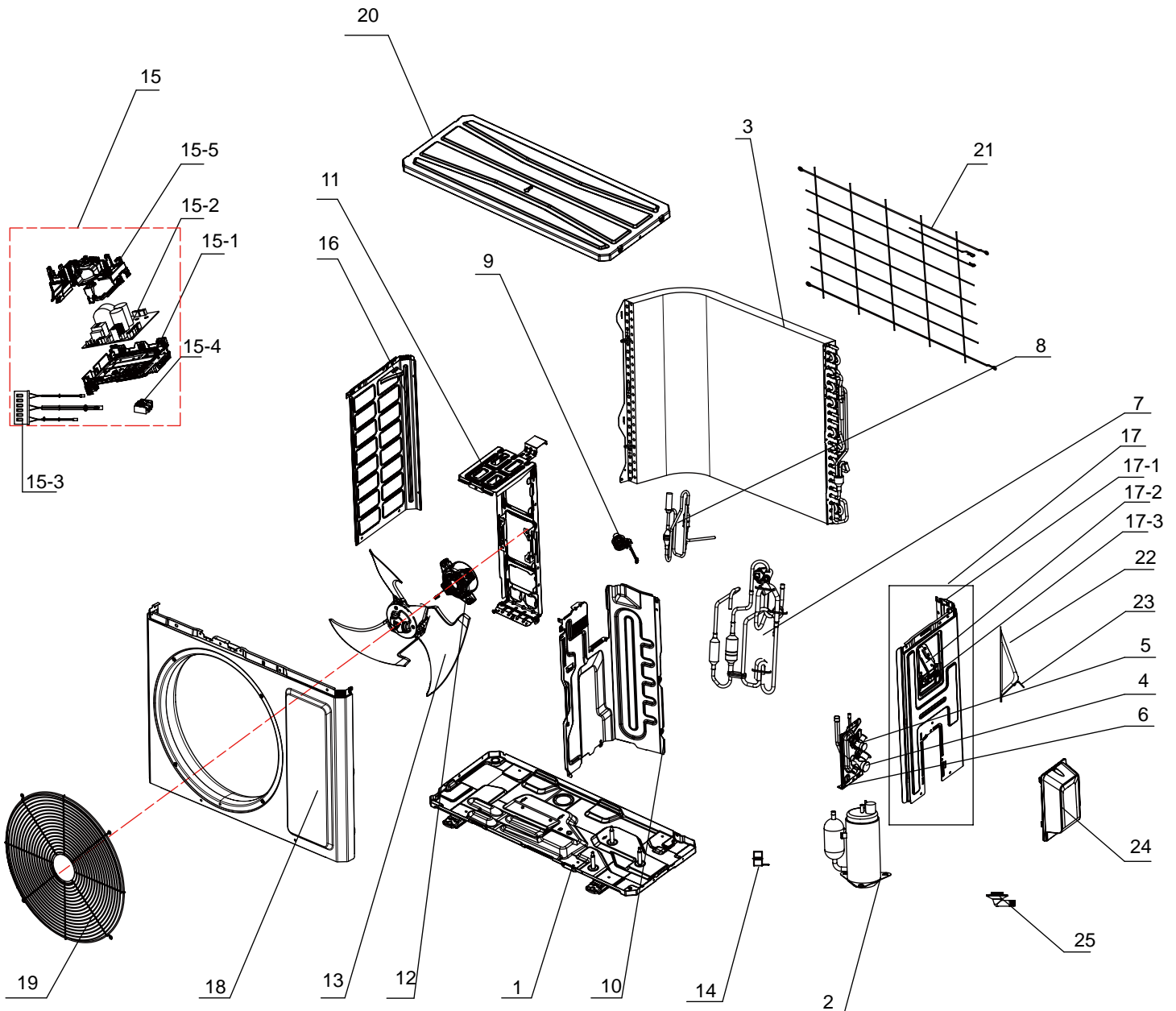

The component picture is only for reference; please refer to the actual product.

NO.	Description
1	Chassis Sub-assy
2	Compressor and Fittings
3	Condenser Assy
4	Cut-off valve big
5	Cut-off valve small
6	Valve Support
7	4-Way Valve Assy
8	Electric Expansion Valve Sub-Assy
9	Electric Expansion Valve Fitting
10	Clapboard
11	Motor Support

NO.	Description
12	Fan Motor
13	Axial Flow Fan
14	Magnet Coil
15	Electric Box Assy
15-1	Electric Box
15-2	Main Board
15-3	Temperature Sensor
15-4	Terminal Board
15-5	Electric Box Cover
16	Left Side Plate
17	Right Side Plate Assy
17-1	Right Side Plate

NO.	Description
17-2	Earthing Plate Sub-assy
17-3	Wire Clamp
18	Cabinet
19	Front Grill
20	Top Cover Assy
21	Rear Grill
22	Cable Cross Plate
23	Cable Cross Plate 1
24	Valve Cover
25	Drainage Joint

Some models may not contain some parts, please refer to the actual product.

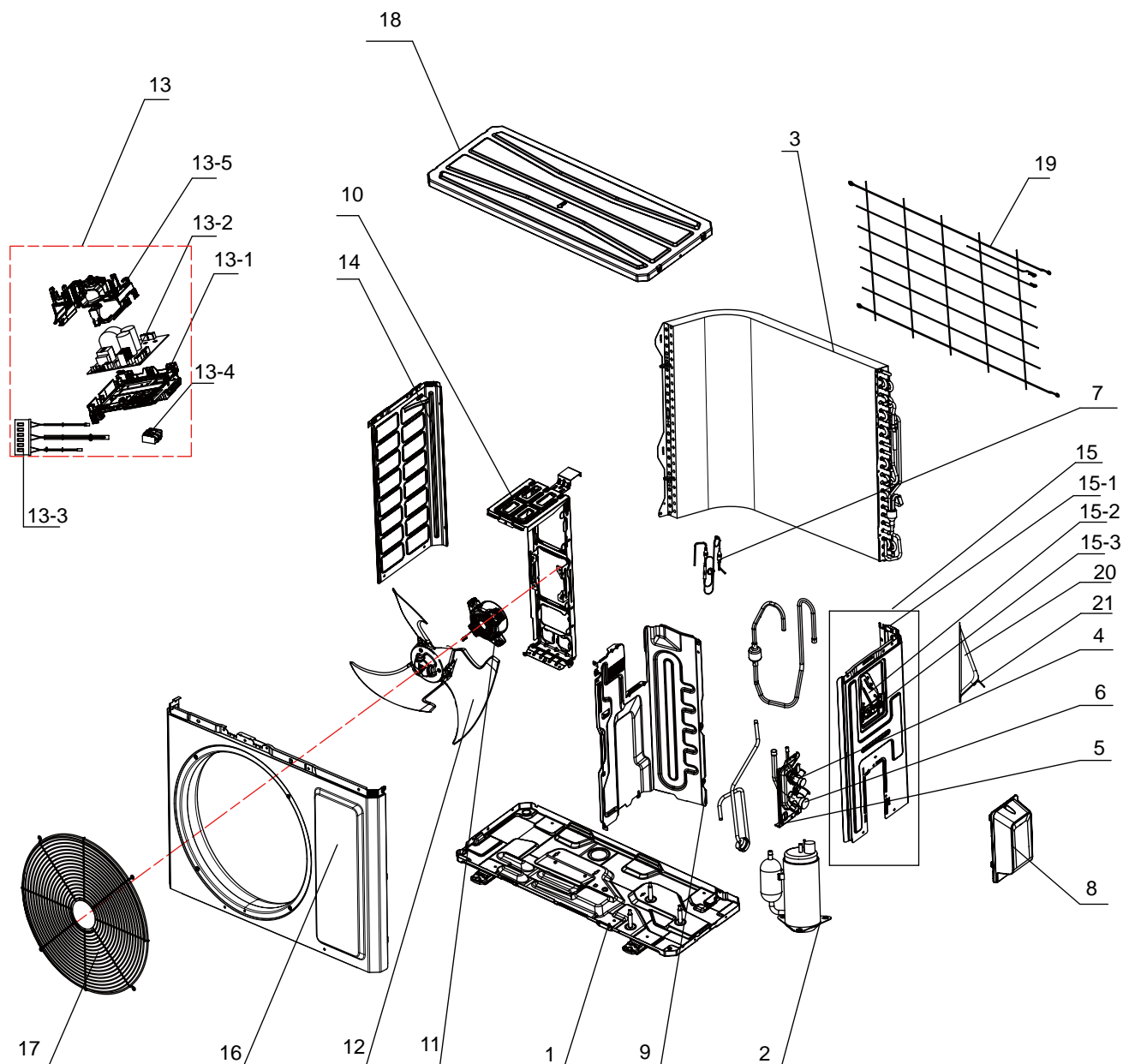

The component picture is only for reference; please refer to the actual product.

NO.	Description
1	Chassis Sub-assy
2	Compressor and Fittings
3	Condenser Assy
4	Cut-off valve small
5	Valve Support
6	Cut-off valve big
7	Capillary Sub-assy
8	Valve Cover
9	Clapboard
10	Motor Support

NO.	Description
11	Fan Motor
12	Axial Flow Fan
13	Electric Box Assy
13-1	Electric Box
13-2	Main Board
13-3	Temperature Sensor
13-4	Terminal Board
13-5	Electric Box Cover
14	Left Side Plate
15	Right Side Plate Assy

NO.	Description
15-1	Right Side Plate
15-2	Earthing Plate Sub-assy
15-3	Wire Clamp
16	Cabinet
17	Front Grill(metal)
18	Top Cover Assy
19	Rear Grill
20	Cable Cross Plate
21	Cable Cross Plate 1

Some models may not contain some parts, please refer to the actual product.

LIV18HP230V1R32AO

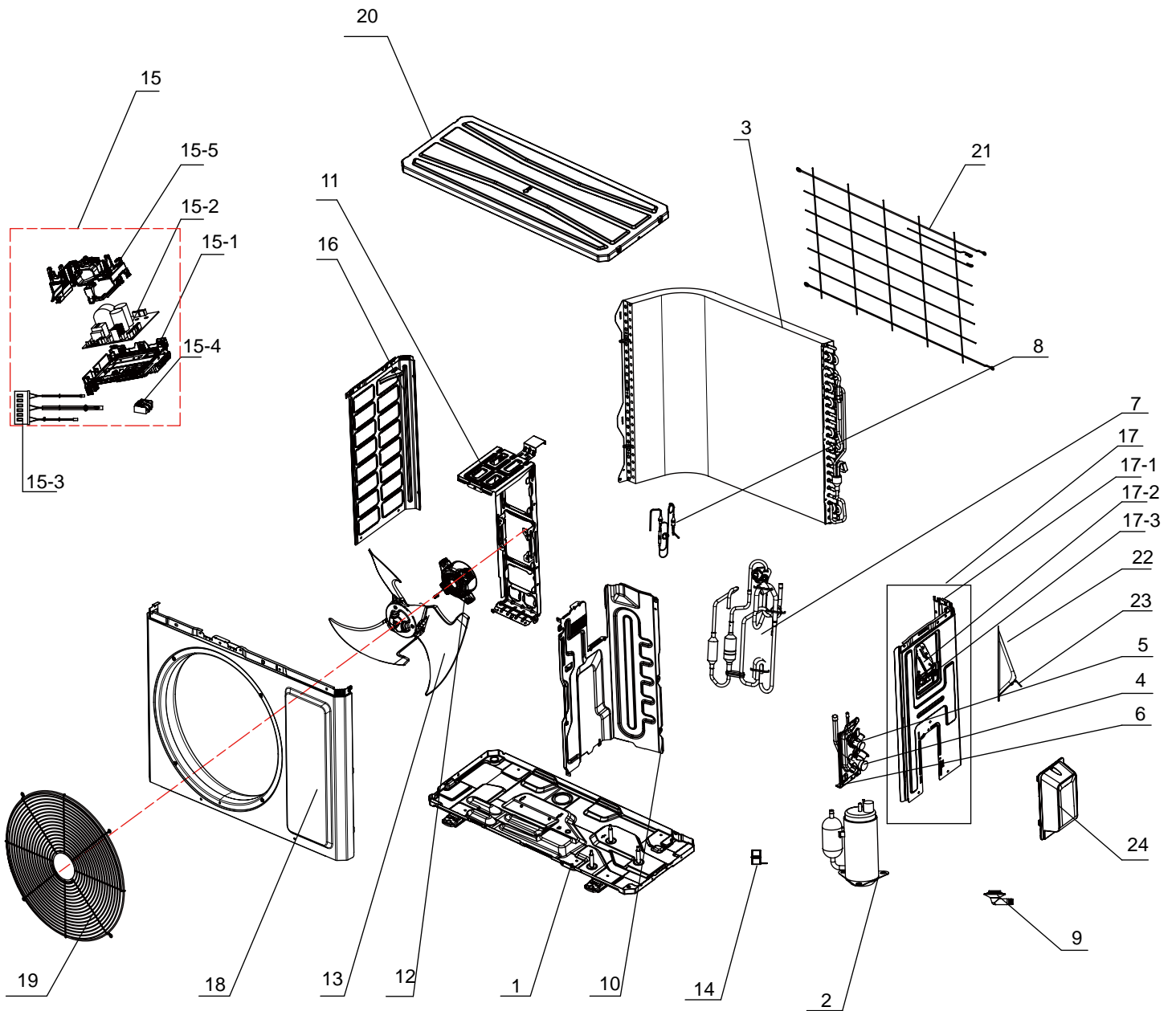

The component picture is only for reference; please refer to the actual product.

NO.	Description
1	Chassis Sub-assy
2	Compressor and Fittings
3	Condenser Assy
4	Cut-off valve big
5	Cut-off valve small
6	Valve Support
7	4-Way Valve Assy
8	Capillary Sub-assy
9	Drainage Joint
10	Clapboard
11	Motor Support

NO.	Description
12	Fan Motor
13	Axial Flow Fan
14	Magnet Coil
15	Electric Box Assy
15-1	Electric Box
15-2	Main Board
15-3	Temperature Sensor
15-4	Terminal Board
15-5	Electric Box Cover
16	Left Side Plate
17	Right Side Plate Assy

NO.	Description
17-1	Right Side Plate
17-2	Earthing Plate Sub-assy
17-3	Wire Clamp
18	Cabinet
19	Front Grill
20	Top Cover Assy
21	Rear Grill
22	Cable Cross Plate
23	Cable Cross Plate 1
24	Valve Cover

Some models may not contain some parts, please refer to the actual product.

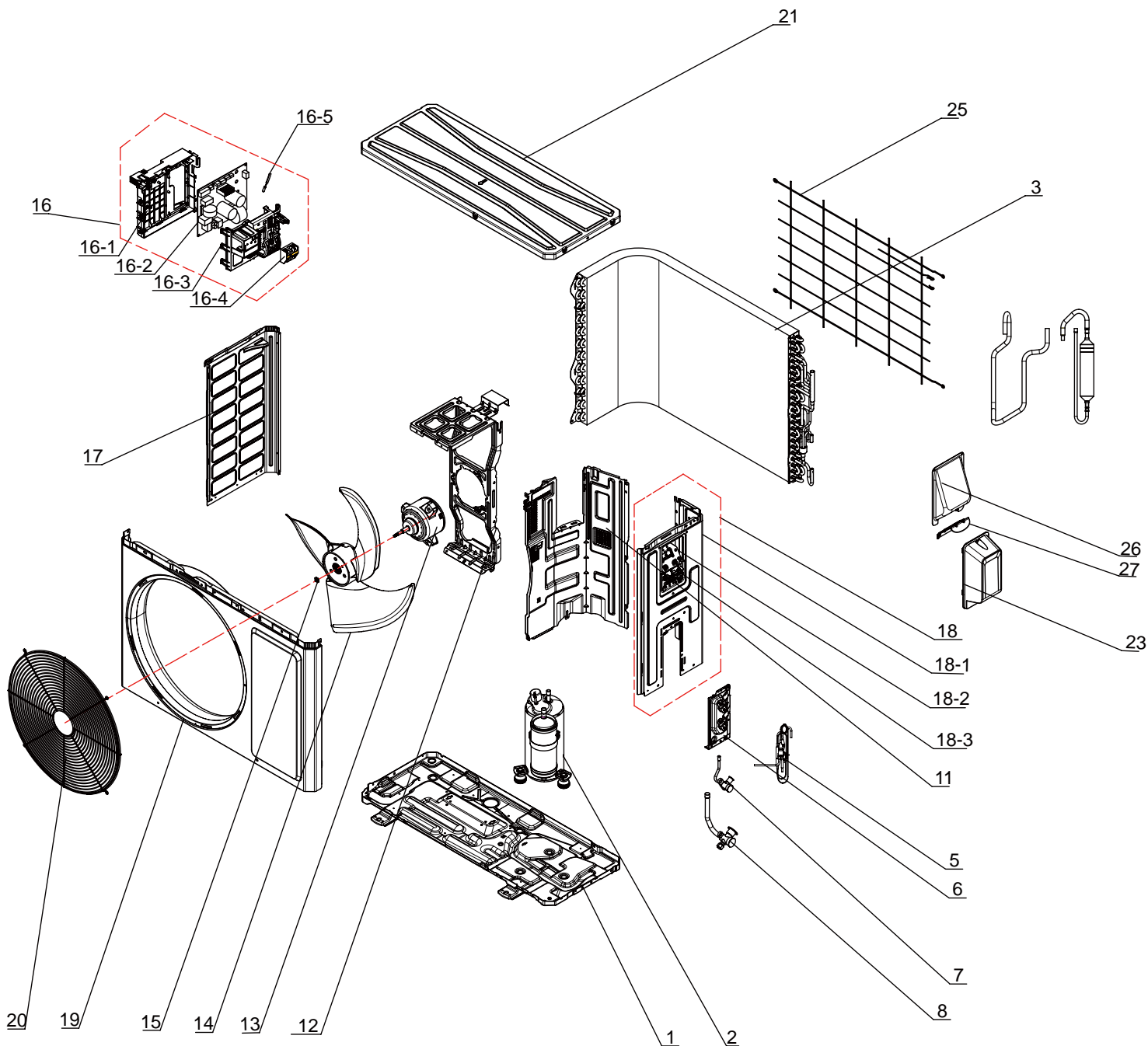

The component is only for reference; please refer to the actual product

NO.	Description
1	Chassis Sub-assy
2	Compressor and Fittings
3	Condenser Assy
5	Capillary Sub-assy
6	Valve Support
7	Cut-off valve
8	Cut-off valve
11	Clapboard
12	Motor Support
13	Fan Motor

NO.	Description
14	Axial Flow Fan
15	Block gasket
16	Electric Box Assy
16-1	Electric Controller Box
16-2	Main Board
16-3	Controller Cover
16-4	Terminal Board
16-5	Temperature Sensor
17	Left Side Plate
18	Right Side Plate Assy

NO.	Description
18-1	Right Side Plate
18-2	Earthing Plate Sub-assy
18-3	Wire Clamp
19	Cabinet
20	Front Grill
21	Top Cover Assy
23	Valve Cover
25	Rear Grill
26	Cable Cross Plate
27	Cable Cross Plate

Some models may not contain some parts, please refer to the actual product.

# GWH18ATDXE-D6DNA1C/O

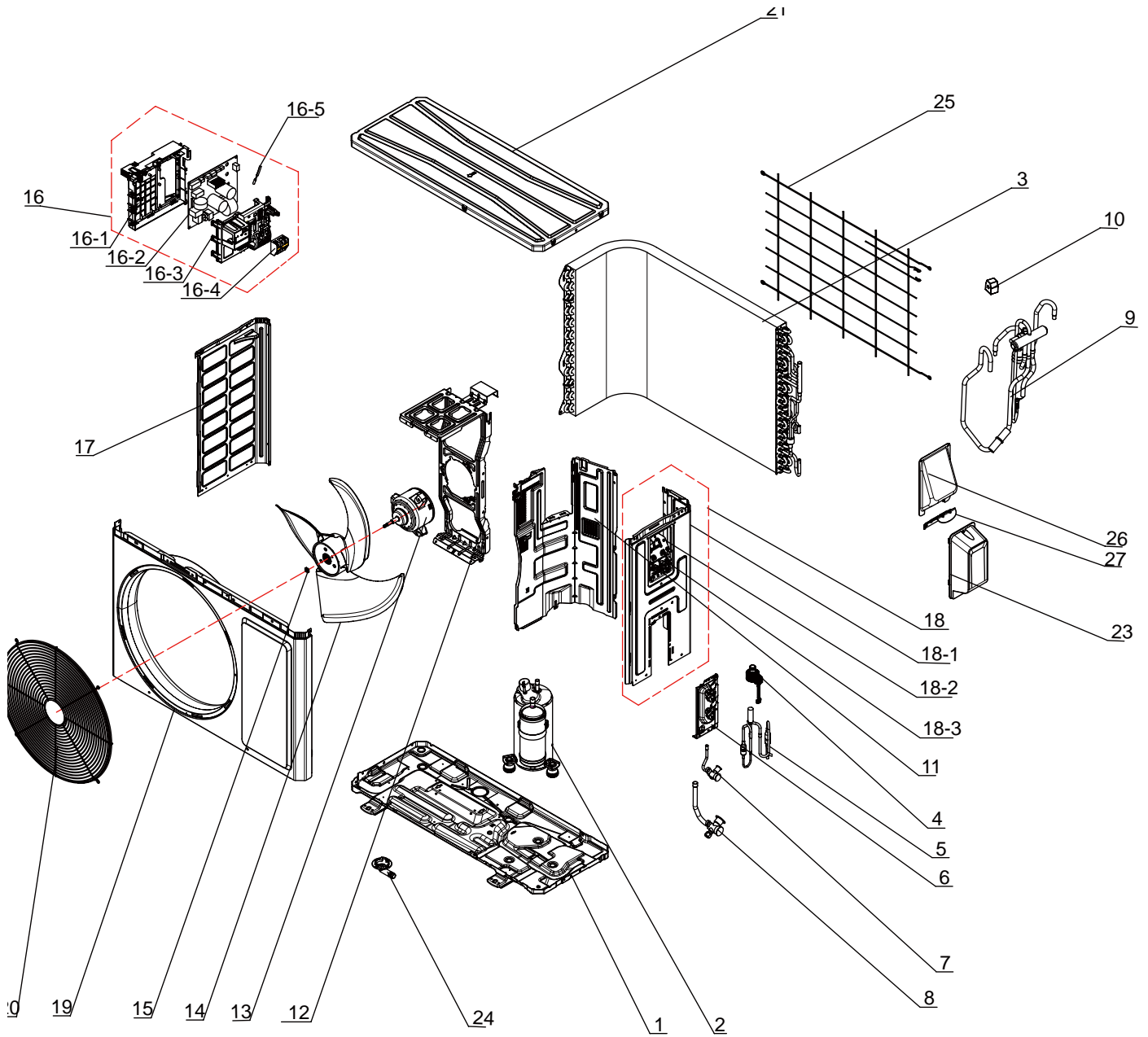

The component is only for reference; please refer to the actual product

NO.	Description
1	Chassis Sub-assy
2	Compressor and Fittings
3	Condenser Assy
4	Electric Expand Valve Fitting
5	Electric Expansion Valve Sub-Assy
6	Valve Support
7	Cut-off valve 1/2(N)
8	Cut-off valve 1/4(N)
9	4-Way Valve Assy
10	4 Way Valve Coil
11	Clapboard

NO.	Description
12	Motor Support
13	Fan Motor
14	Axial Flow Fan
15	Block gasket
16	Electric Box Assy
16-1	Electric Controller Box
16-2	Main Board
16-3	Controller Cover
16-4	Terminal Board
16-5	Temperature Sensor
17	Left Side Plate

NO.	Description
18	Right Side Plate Assy
18-1	Right Side Plate
18-2	Earthing Plate Sub-assy
18-3	Wire Clamp
19	Cabinet
20	Front Grill
21	Top Cover Assy
23	Valve Cover
24	Drainage Joint
25	Rear Grill
26	Cable Cross Plate
27	Cable Cross Plate

Some models may not contain some parts, please refer to the actual product.

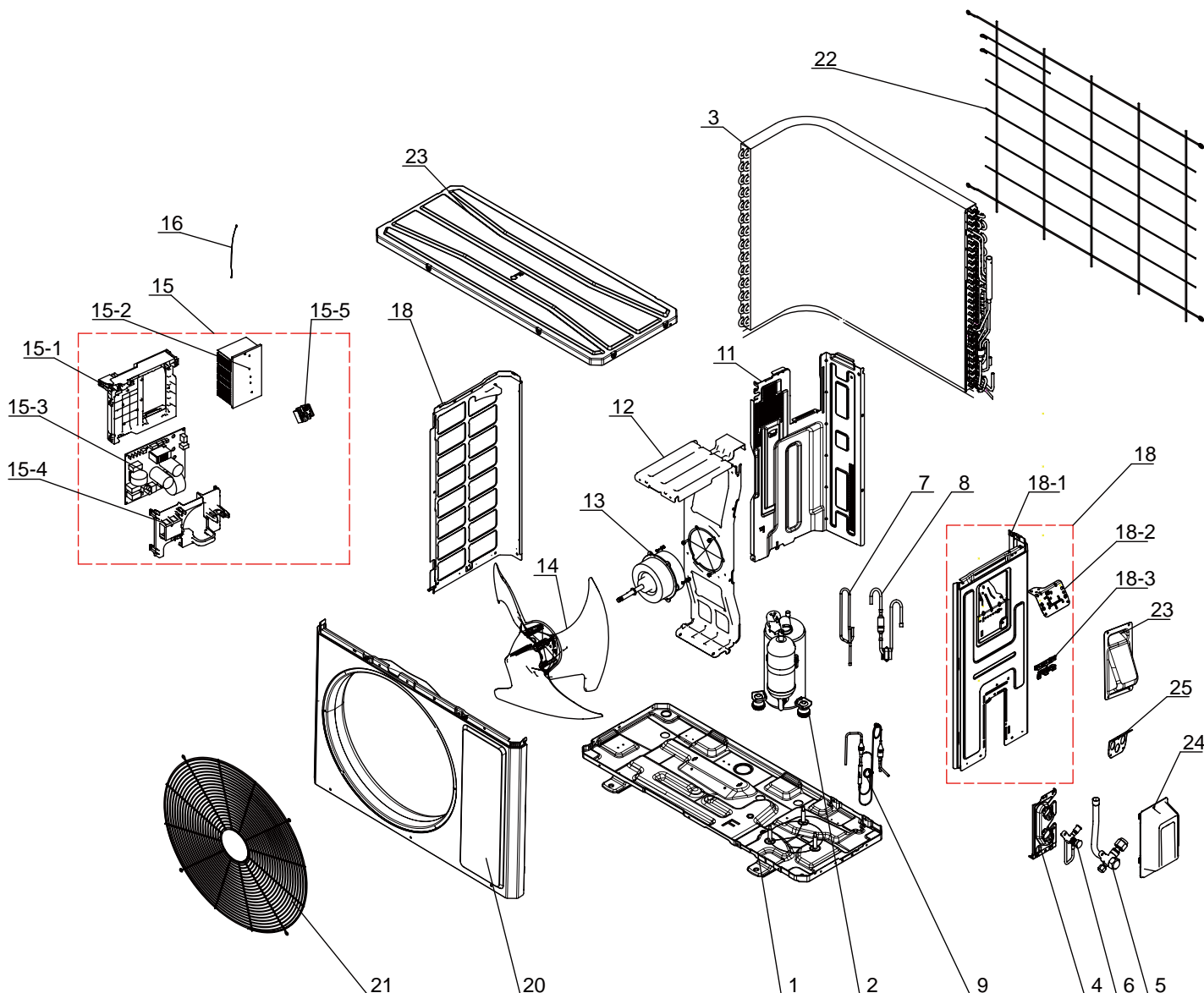

The component picture is only for reference; please refer to the actual product.

NO.	Description
1	Chassis Sub-assy
2	Compressor and Fittings
3	Condenser Assy
4	Valve Support
5	Cut-off valve big
6	Cut-off valve small
7	Discharge Tube
8	Inhalation Tube Sub-assy
9	Capillary Sub-assy
11	Clapboard
12	Motor Support

NO.	Description
13	Motor
14	Axial Flow Fan
15	Electric Box Assy
15-1	Electric Box
15-2	Radiator
15-3	Main Board
15-4	Electric Box Cover
15-5	Terminal Board
16	Temperature Sensor
17	Left Side Plate
18	Right Side Plate Assy

NO.	Description
18-1	Right Side Plate
18-2	Earthing Plate Sub-assy
18-3	Wire Clamp
19	Front Panel
20	Grill
21	Rear Grill
22	Top Cover Assy
23	Handle
24	Valve Cover
25	Cable Cross Plate

Some models may not contain some parts, please refer to the actual product.

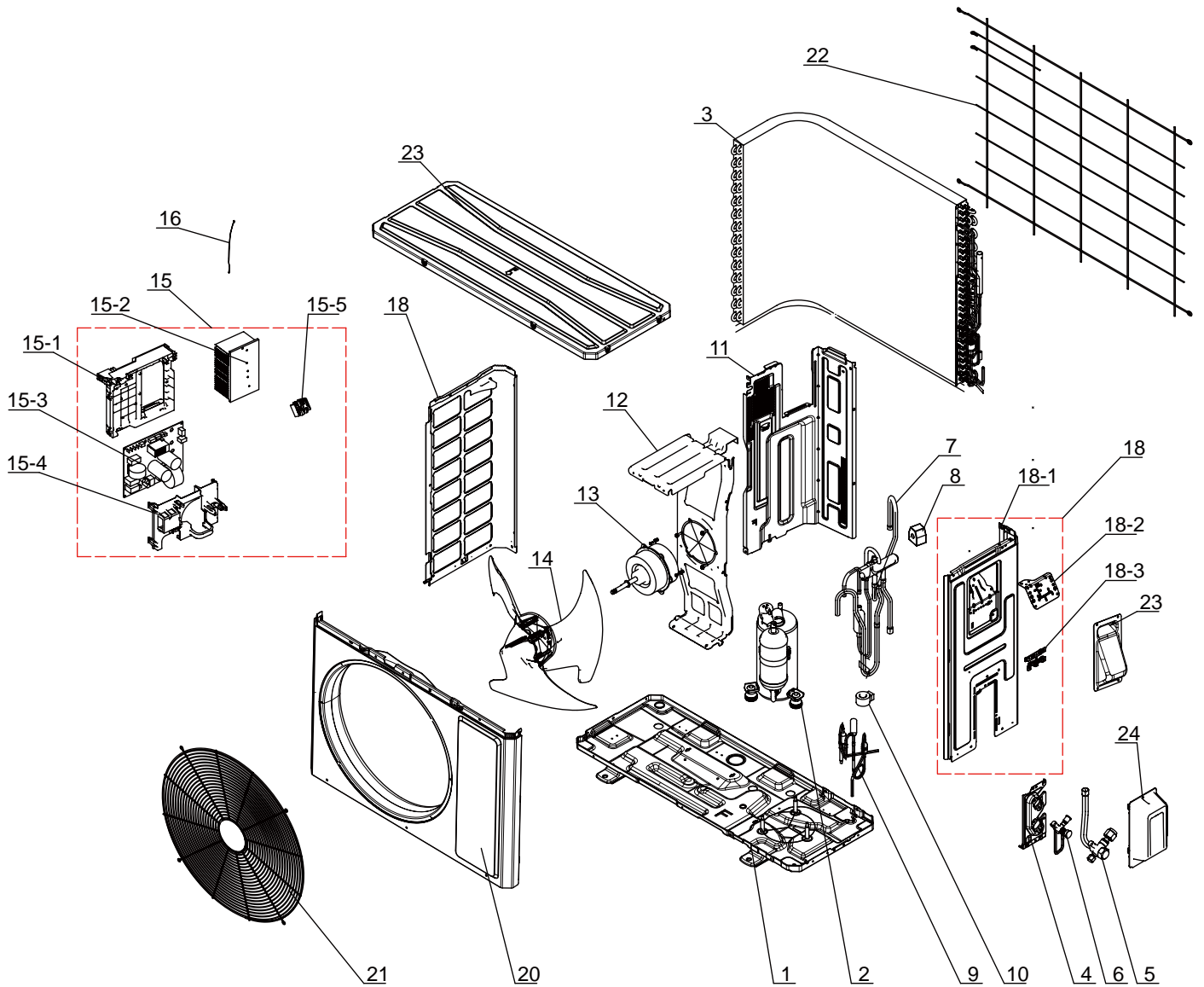

The component picture is only for reference; please refer to the actual product.

NO.	Description
1	Chassis Sub-assy
2	Compressor and Fittings
3	Condenser Assy
4	Valve Support
5	Cut-off valve big
6	Cut-off valve small
7	4-Way Valve Assy
8	Magnet Coil
9	Electric Expansion Valve Sub-Assy
10	Electric Expand Valve Fitting

NO.	Description
11	Clapboard
12	Motor Support
13	Motor
14	Axial Flow Fan
15	Electric Box Assy
15-1	Electric Box
15-2	Radiator
15-3	Main Board
15-4	Electric Box Cover
15-5	Terminal Board
16	Temperature Sensor

NO.	Description
17	Left Side Plate
18	Right Side Plate Assy
18-1	Right Side Plate
18-2	Earthing Plate Sub-assy
18-3	Wire Clamp
19	Front Panel
20	Grill
21	Rear Grill
22	Top Cover Assy
23	Handle
24	Valve Cover

Some models may not contain some parts, please refer to the actual product.

# GWC36ATEXH-D6DNA1G/O

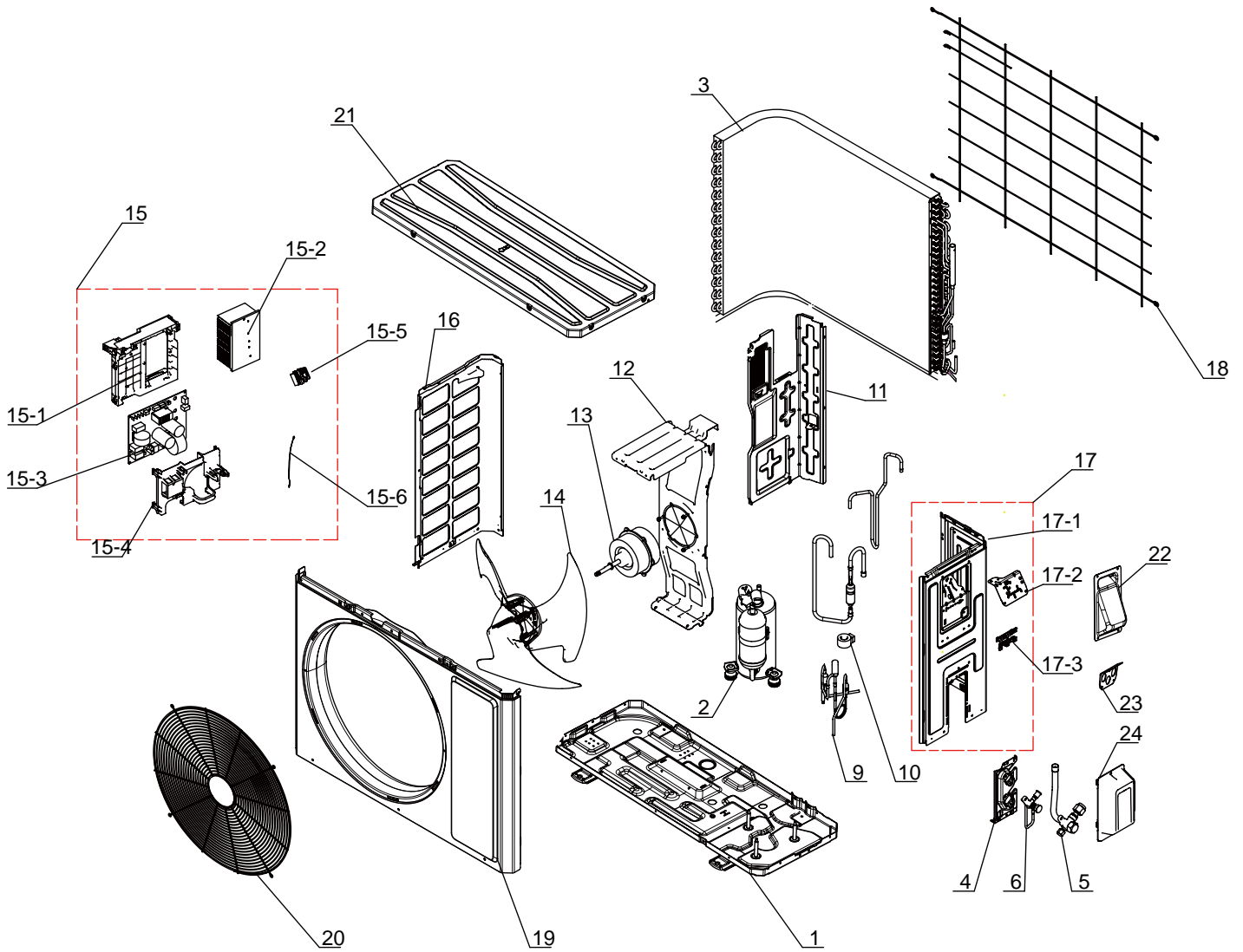

The component picture is only for reference; please refer to the actual product.

NO.	Description
1	Chassis Sub-assy
2	Compressor and Fittings
3	Condenser Assy
4	Valve Support
5	Cut-off valve big
6	Cut-off valve small
9	Electric Expansion Valve Sub-Assy
10	Electric Expand Valve Fitting
11	Clapboard Sub-Assy
12	Motor Support
13	Motor

NO.	Description
14	Axial Flow Fan
15	Electric Box Assy
15-1	Electric Box
15-2	Radiator
15-3	Main Board
15-4	Electric Box Cover
15-5	Terminal Board
15-6	Temperature Sensor
16	Left Side Plate
17	Right Side Plate Assy
17-1	Right Side Plate

NO.	Description
17-2	Terminal Board Support sub-assy
17-3	Wire Clamp
18	Rear Grill
19	Front Panel
20	Front Grill
21	Top Cover Assy
22	Handle
23	Cable Cross Plate
24	Valve Cover

Some models may not contain some parts, please refer to the actual product.



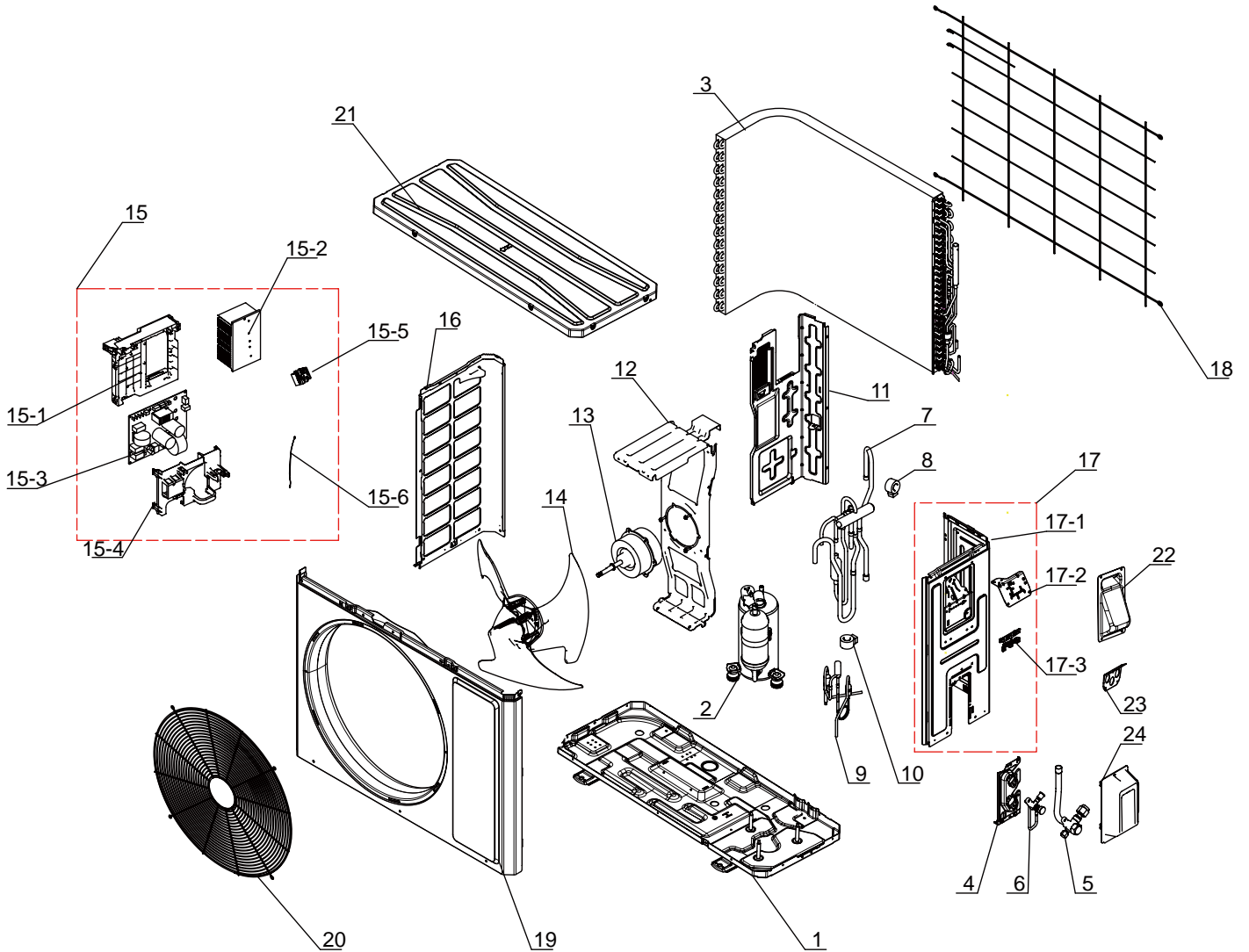

The component picture is only for reference; please refer to the actual product.

NO.	Description
1	Chassis Sub-assy
2	Compressor and Fittings
3	Condenser Assy
4	Valve Support
5	Cut-off valve big
6	Cut-off valve small
7	4-Way Valve Assy
8	Magnet Coil
9	Electric Expansion Valve Sub-Assy
10	Electric Expand Valve Fitting
11	Clapboard Sub-Assy
12	Motor Support

NO.	Description
13	Motor
14	Axial Flow Fan
15	Electric Box Assy
15-1	Electric Box
15-2	Radiator
15-3	Main Board
15-4	Electric Box Cover
15-5	Terminal Board
15-6	Temperature Sensor
16	Left Side Plate
17	Right Side Plate Assy
17-1	Right Side Plate

NO.	Description
17-2	Terminal Board Support sub-assy
17-3	Wire Clamp
18	Rear Grill
19	Front Panel
20	Front Grill
21	Top Cover Assy
22	Handle
23	Cable Cross Plate
24	Valve Cover

Some models may not contain some parts, please refer to the actual product.

# 11. Removal Procedure



## 11.1 Removal Procedure of Indoor Unit



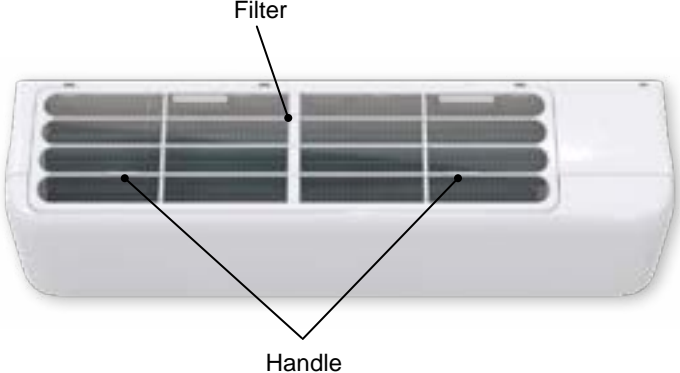
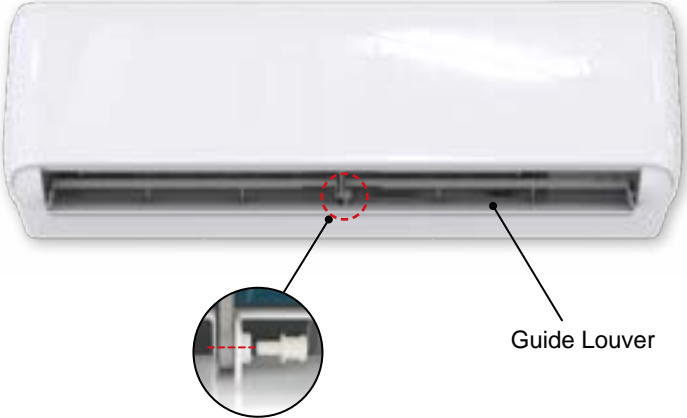

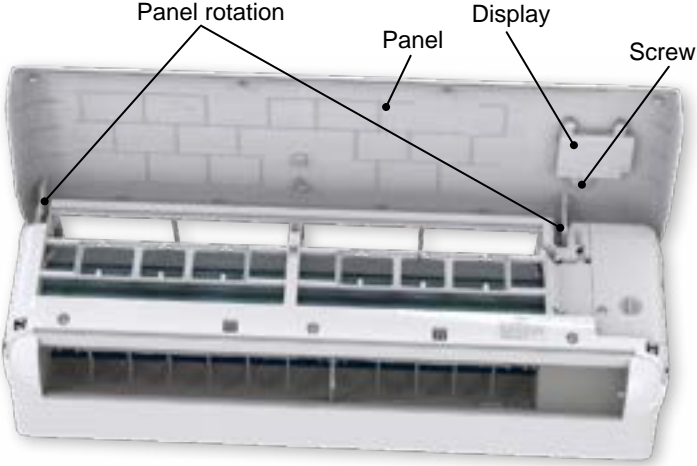
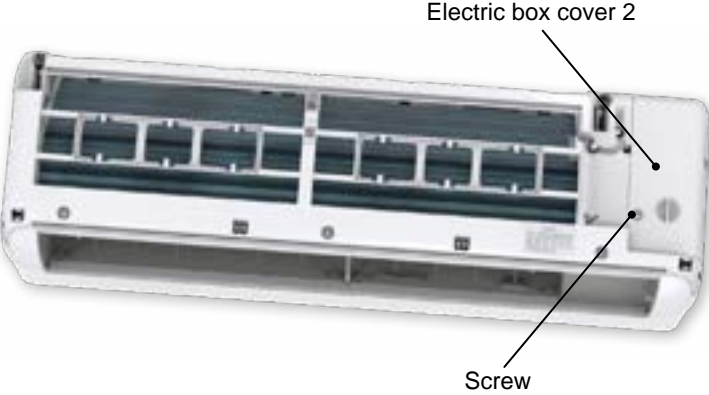
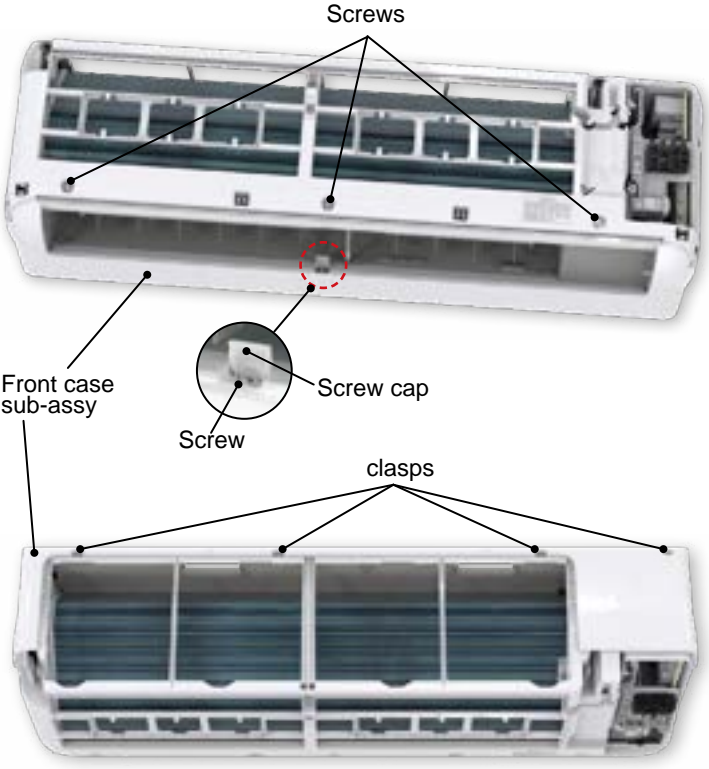
**Warning:** Before disassembly, please disconnect the power supply. Before disconnection the pipeline, please discharge all the refrigerant according to the local laws and regulations.

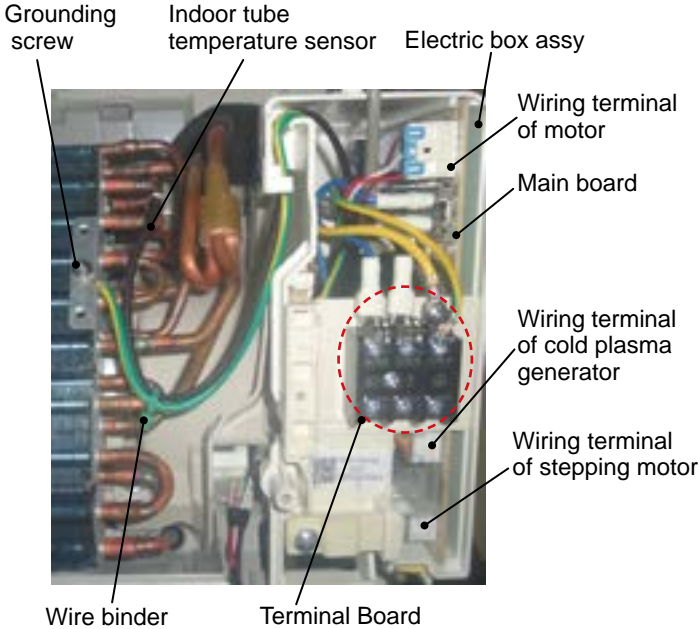
Step	Procedure
<b>Before disassemble</b>	<p>Turn off the air conditioner and disconnect the power before disassemble the air conditioner.</p> 
<b>1. Remove filter</b>	<p>Hold the handle on the filter, pull it upwards to let the clasp at the top part of the filter loose, pull it forwards and then the filter can be pulled out.</p> 
<b>2. Remove guide louver</b>	<p>Push out the plug pin on guide louver, bend the guide louver with hand and then separate the guide louver from the crank shaft of step motor to remove it.</p> 

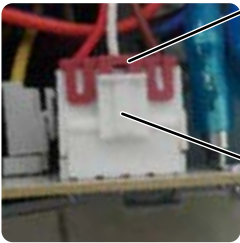
Step	Procedure
<p><b>3. Remove panel</b></p> <p>Open the front panel; separate the panel rotation shaft from the groove fixing the front panel and then removes the front panel.</p> <p>Note: The display of some models is fixed on the panel; unscrew the screws fixing the display on the panel before removing the panel.</p>	
<p><b>4. Remove electric box cover 2</b></p> <p>Remove the screws on the electric box cover 2 to remove the electric box cover 2.</p>	
<p><b>5. Remove front case sub-assy</b></p> <p>a Remove the screws fixing front case.</p> <p>Note: (1) Open the screw caps before removing the screws around the air outlet. (2) The quantity of screws fixing the front case sub-assy is different for different models.</p> <p>b Loosen the 4 clasps of front case. Lift the front case sub-assy upwards to remove it.</p>	

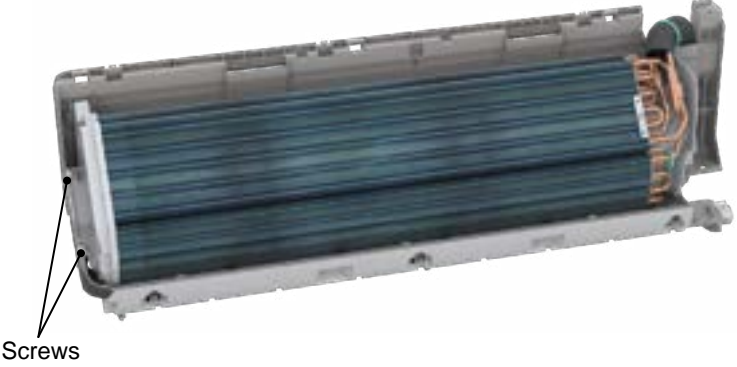
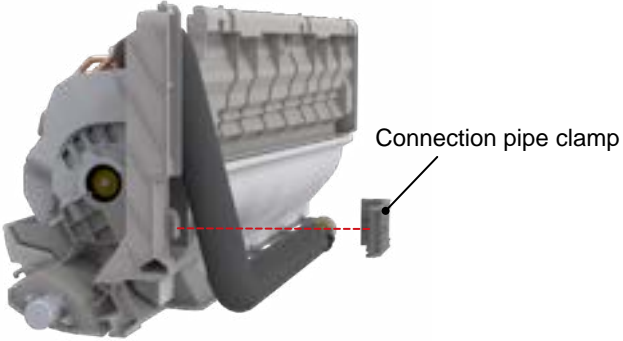
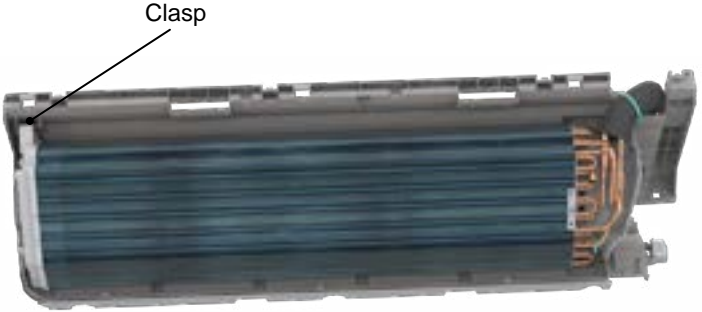
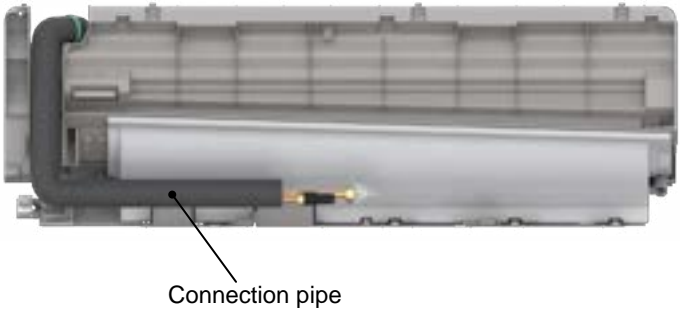
Step	Procedure
<b>6. Remove electric box assy</b>	
a	<p>Remove the screw fixing electric box assy.</p> 
b	<p>           ① Cut off the wire binder and pull out the indoor tube temperature sensor.            ② Screw off one grounding screw.            ③ Unscrew the screws of terminal board and remove the terminal board..            ④ Remove the PCB, remove the wire terminals.            ⑤ Unscrew the screws of gas sensor.         </p> 
c	<p>Instruction:Some wiring terminal of this products is with lock catch and other devices.The pulling method is as below:</p> <p>1.Remove the soft sheath for some terminals at first, hold the circlip and then pull out the terminals,            2.Pull out the holder for some terminals at first(holder is not available for some wiring terminal).hold the connector and then pull the terminal.</p>   

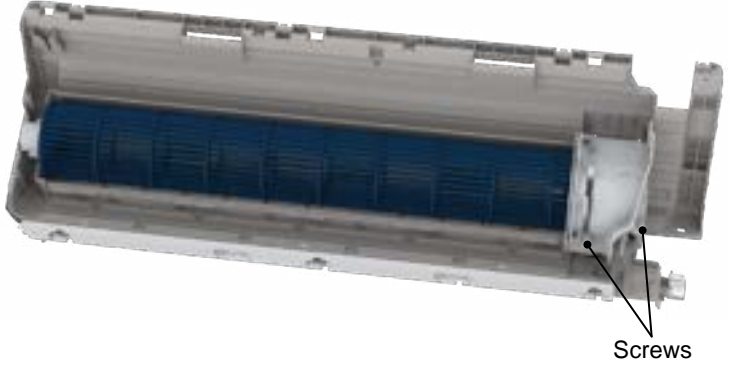
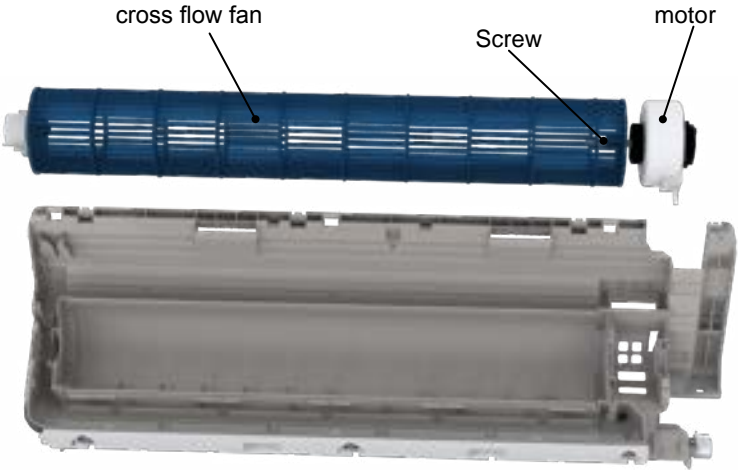
Step	Procedure
<b>7. Remove evaporator assy</b>	
a	<p>Remove 2 screws fixing evaporator assy.</p> 
b	<p>At the back of the unit, Loosen the clasp of the connection pipe clamp and then remove the connection pipe clamp.</p> 
c	<p>First remove the left side of evaporator from the groove of bottom shell and then remove the right side from the clasp on the bottom shell.</p> 
d	<p>Adjust the position of connection pipe on evaporator slightly and then lift the evaporator upwards to remove it.</p> 



Step	Procedure
<b>8. Remove motor and cross flow fan</b>	
a	<p>Remove 3 screws fixing motor clamp and then remove the motor clamp.</p>  <p style="text-align: right;">Screws</p>
b	<p>Loose the screws (2-3 circles) used for fixing the cross flow fan, pull right to pull out the motor.</p>  <p style="text-align: right;">cross flow fan      Screw      motor</p>
<b>9. Remove swing motor</b>	
	<p>Screw off the screws that are locking the swing motor and take the motor off.</p>  <p style="text-align: center;">Screws</p>

## 11.2 Removal Procedure of Outdoor Unit

XB :Take the heat pump for example



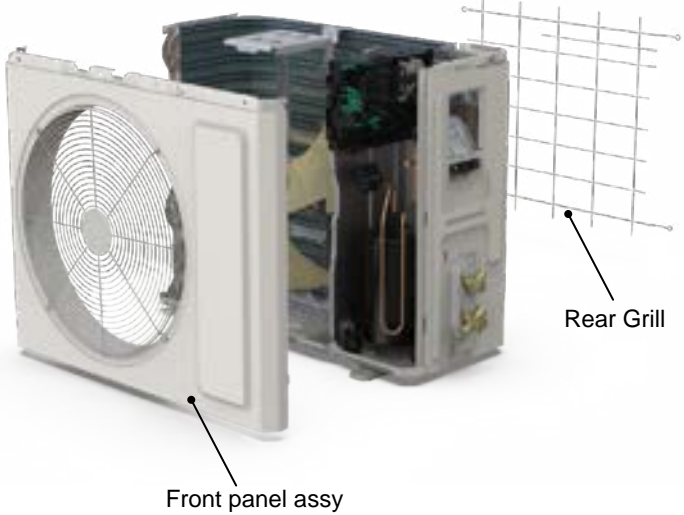
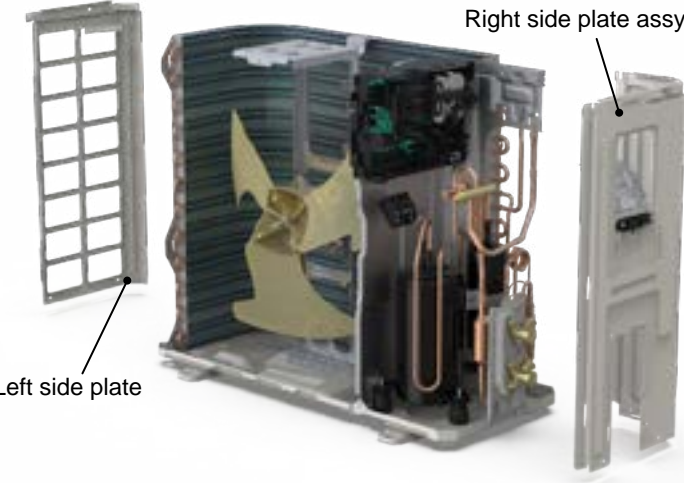
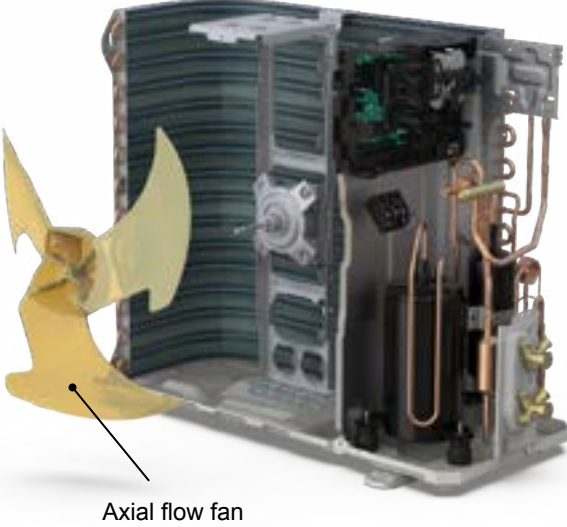

**Warning:** Before disassembly, please disconnect the power supply. Before disconnection the pipeline, please discharge all the refrigerant according to the local laws and regulations.

Step	Procedure
<p><b>1. Before disassembly</b></p>	
<p><b>2. Remove Cover of Pass Wire and valve cover</b></p>	<p>Remove the screws fixing Cover of Pass Wire, valve cover and then remove them.</p> 
<p><b>3. Remove top cover</b></p>	<p>Remove the screws fixing top panel and then remove the top panel.</p> 

Step	Procedure
<p><b>4. Remove front panel assy and Rear Grill</b></p>	<p>Remove connection screws connecting the front panel assy and Rear Grill, and then remove the front panel assy and Rear Grill.</p> 
<p><b>5. Remove right side plate assy and left side plate</b></p>	<p>Rescrew the ground screws, remove the ground wires, loosen the screws fixing terminal board, remove the terminal board, rescrew the screws fixing the right side plate, and remove the right side plate assy. Rescrew the screws fixing the left side plate, and remove the left side plate assy.</p> 
<p><b>6. Remove axial flow fan</b></p>	<p>Remove the nut on the fan and then remove the axial flow fan.</p> 

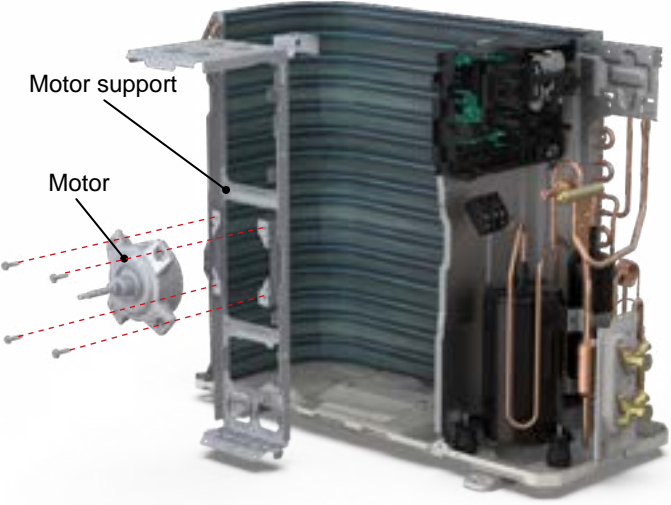

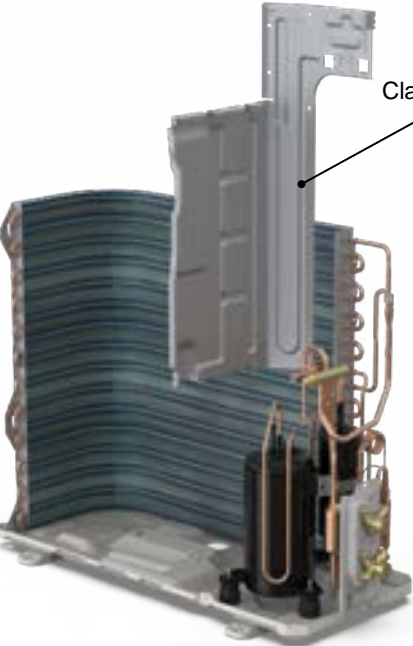

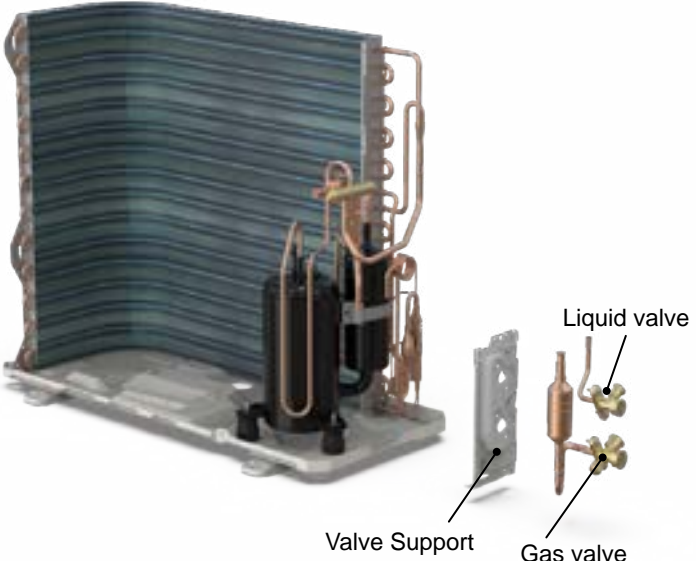
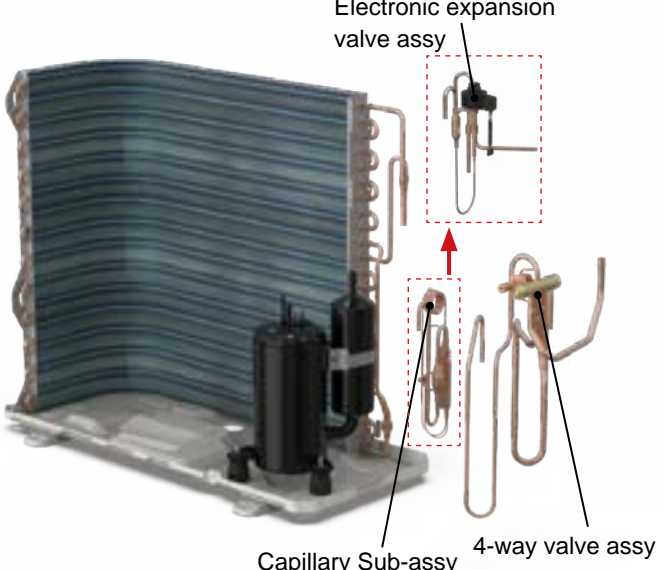
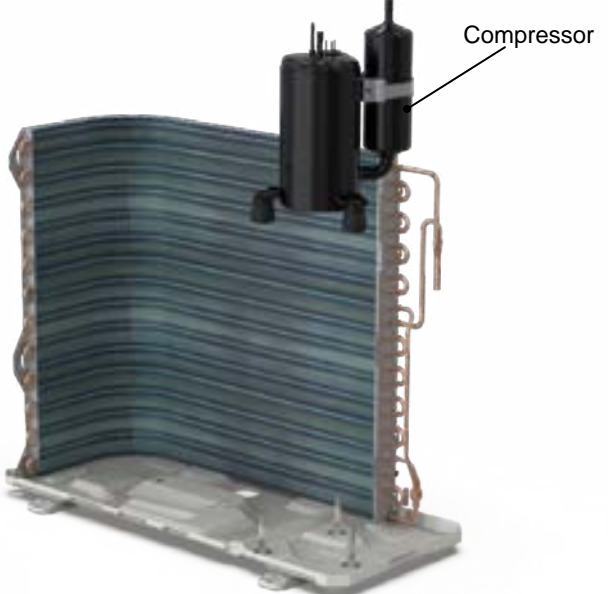
Step	Procedure
<p><b>7. Remove motor support and motor</b></p>	<p>Remove the screws fixing the motor support and lift the motor support to remove it. Remove the screws fixing the motor and then remove the motor.</p>  <p>Motor support</p> <p>Motor</p>
<p><b>8. Remove electric box assy</b></p>	<p>Remove the terminals, lift up and rotate the electrical box assy to the right so that the snaps on the clapboard are removed and the electrical box assy are removed.</p>  <p>Electric box assy</p>
<p><b>9. Remove clapboard assy</b></p>	<p>Remove the screws fixing the clapboard assy and then remove the clapboard assy.</p>  <p>Clapboard assy</p>



Step	Procedure
<p><b>10. Remove gas valve and liquid valve</b></p> <p>Remove the valve support block, remove the screws fixing the gas valve and the liquid valve, unsolder the welding joint connecting the gas valve and the liquid valve, remove them.</p> <p>Note: Discharge the refrigerant completely before unsoldering; when unsoldering, wrap the gas valve with a wet cloth completely to avoid damage to the valve caused by high temperature.</p>	 <p>Valve Support Gas valve Liquid valve</p>
<p><b>11. Remove 4-way valve and capillary Sub-assy(electronic expansion valve assy)</b></p> <p>Unsolder the welding joints connecting capillary Sub-assy(electronic expansion valve assy), and then remove it.</p> <p>Unsolder the welding joints connecting the 4-way valve assy with capillary sub-assy(electronic expansion valve assy), compressor and condenser; remove the 4-way valve and capillary Sub-assy(electronic expansion valve assy). Cooling only unit removes Discharge Tube and Inhalation Tube.</p> <p>Note: Before unsoldering the welding joint, wrap the 4-way valve with a wet cloth completely to avoid damage to the valve caused by high temperature.</p>	 <p>Electronic expansion valve assy Capillary Sub-assy 4-way valve assy</p>
<p><b>12. Remove compressor</b></p> <p>Remove the 3 foot nuts on the compressor and then remove the compressor.</p>	 <p>Compressor</p>





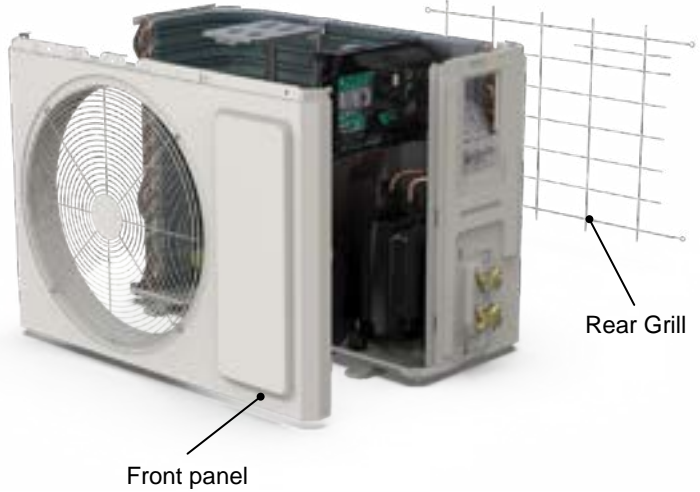
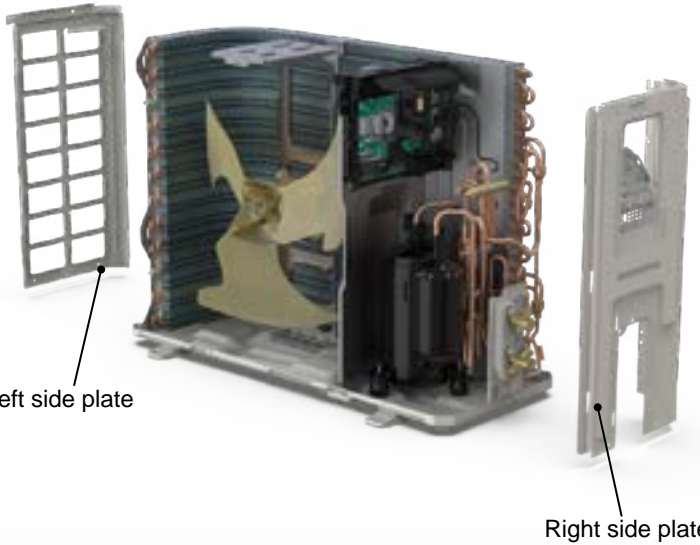

**Warning: Before disassembly, please disconnect the power supply. Before disconnection the pipeline, please discharge all the refrigerant according to the local laws and regulations.**

XD :Take the heat pump for example

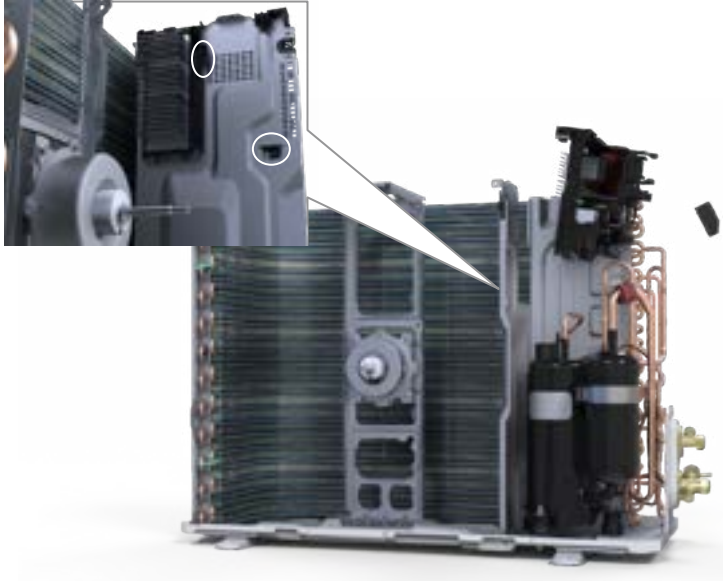
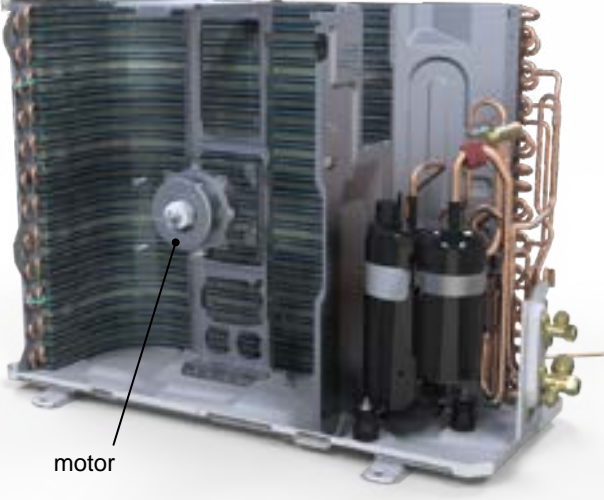
Step	Procedure
<b>1. Before disassembly</b>	
<b>2. Remove Cover of Pass Wire and valve cover</b>	<p data-bbox="191 1109 789 1166">Remove the screws fixing Cover of Pass Wire, valve cover and then remove them.</p> 
<b>3. Remove top cover</b>	<p data-bbox="191 1712 789 1769">Remove the screws fixing top panel and then remove the top panel.</p> 

Step	Procedure
<p><b>4. Remove front panel assy and Rear Grill</b></p>	<p>Remove connection screws connecting the front panel assy and Rear Grill, and then remove the front panel assy and Rear Grill.</p> 
<p><b>5. Remove right side plate assy and left side plate</b></p>	<p>Rescrew the ground screws, remove the ground wires, loosen the screws fixing terminal board, remove the terminal board, rescrew the screws fixing the right side plate, and remove the right side plate assy. Rescrew the screws fixing the left side plate, and remove the left side plate assy.</p> 
<p><b>6. Remove axial flow fan</b></p>	<p>Remove the nut on the fan and then remove the axial flow fan.</p> 

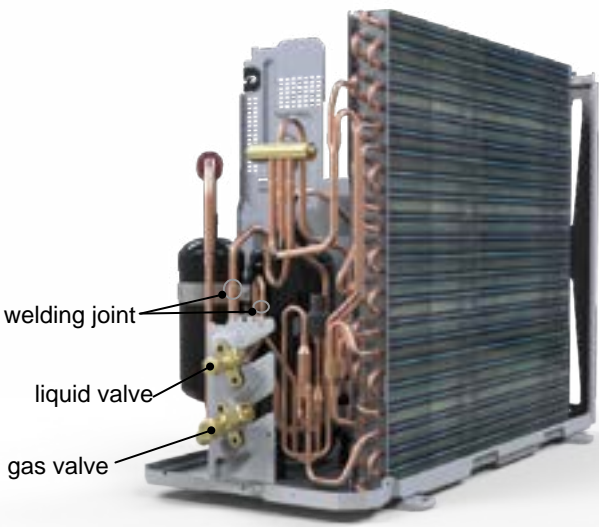
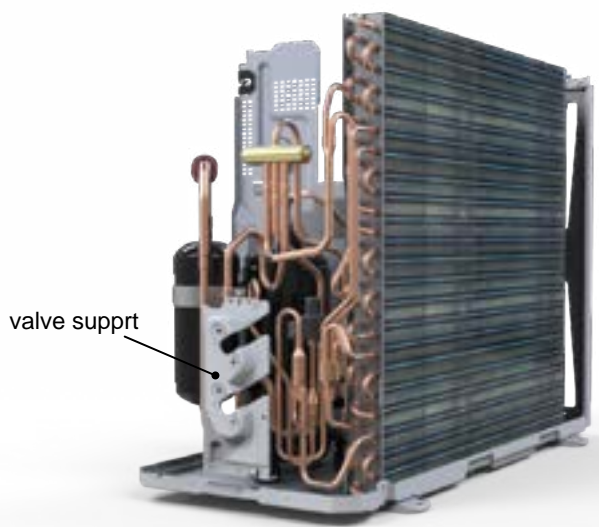
Step	Procedure
<p><b>7. Remove electric box assy</b></p>	<p>Remove the terminals, lift up and rotate the electrical box assy to the right so that the snaps on the clapboard are removed and the electrical box assy are removed.</p> 
<p><b>8. Remove motor</b></p>	<p>Remove the screws fixing the motor and then remove the motor.</p> 
<p><b>9. Remove motor support</b></p>	<p>Remove the screws fixing the motor support and lift the motor support to remove it.</p> 



Step	Procedure
<p><b>10. Remove gas valve and liquid valve</b></p> <p>Remove the valve support block, remove the screws fixing the gas valve and the liquid valve, unsolder the welding joint connecting the gas valve and the liquid valve, remove them.</p> <p>Note: Discharge the refrigerant completely before unsoldering; when unsoldering, wrap the gas valve with a wet cloth completely to avoid damage to the valve caused by high temperature.</p>	 <p>welding joint</p> <p>liquid valve</p> <p>gas valve</p>
<p><b>11. Remove valve support</b></p> <p>Remove the screws fixing valve support, then remove the valve support.</p>	 <p>valve support</p>
<p><b>12. Remove 4-way valve assy</b></p> <p>Unsolder the welding joints connecting the 4-way valve assy, remove the 4-way valve.</p> <p>Note: Before unsoldering the welding joint, wrap the 4-way valve with a wet cloth completely to avoid damage to the valve caused by high temperature.</p>	 <p>4-way valve assy</p>

Step	Procedure
<p><b>13. Remove electronic expansion</b></p>	<p>Unsolder the welding joints connecting electronic expansion valve assy then remove the electronic expansion valve assy.</p> 
<p><b>14. Remove clapboard assy</b></p>	<p>Remove the screws fixing the clapboard assy and then remove the clapboard assy.</p> 
<p><b>15. Remove compressor</b></p>	<p>Remove the 3 foot nuts on the compressor and then remove the compressor.</p> 



XE: Take heat pump for example.

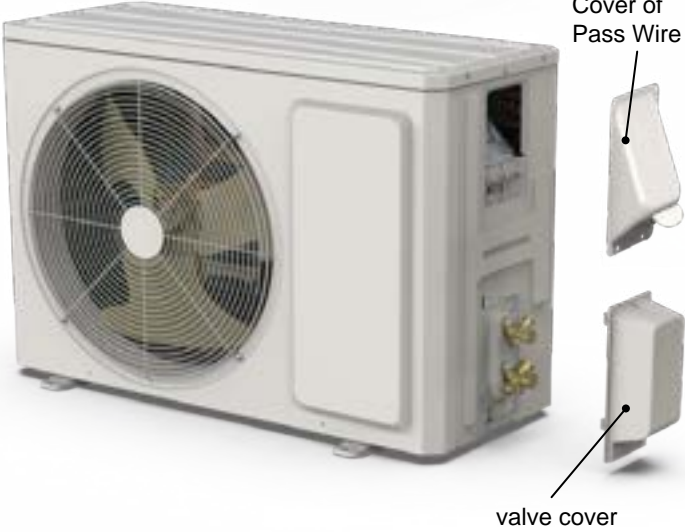

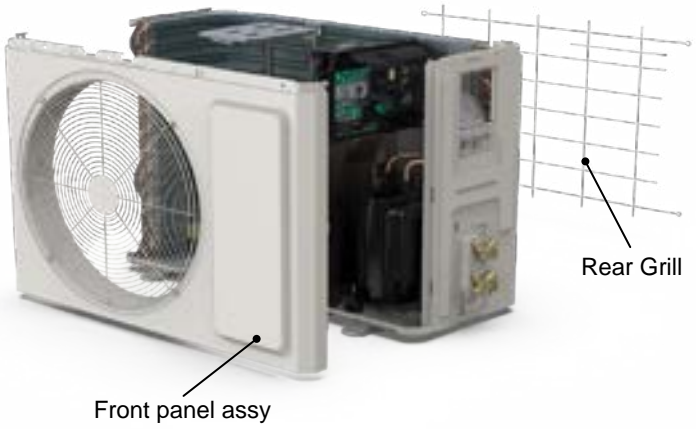

**Warning: Before disassembly, please disconnect the power supply. Before disconnection the pipeline, please discharge all the refrigerant according to the local laws and regulations.**

Step	Procedure
<b>1. Before disassembly</b>	
<b>2. Remove Cover of Pass Wire and valve cover</b>	<p data-bbox="191 1109 789 1166">Remove the screws fixing Cover of Pass Wire, valve cover and then remove them.</p> 
<b>3. Remove top cover</b>	<p data-bbox="191 1712 789 1769">Remove the screws fixing top panel and then remove the top panel.</p> 

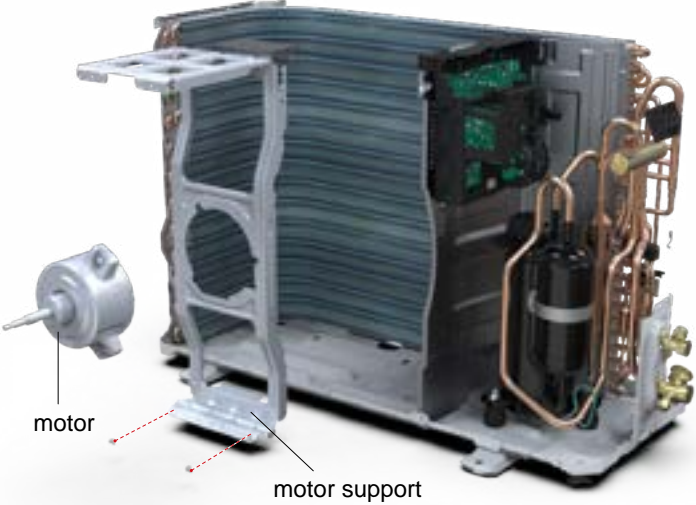

Step	Procedure
<p><b>4. Remove front panel assy and Rear Grill</b></p>	<p>Remove connection screws connecting the front panel assy and Rear Grill, and then remove the front panel assy and Rear Grill.</p> 
<p><b>5. Remove right side plate</b></p>	<p>Remove connection screws connecting the right side plate with the valve support and the electric box. Then remove the right side plate.</p> 
<p><b>6. Remove the nut and gasket on the blade and then remove the axial flow blade</b></p>	<p>Remove the nut and gasket on the blade and then remove the axial flow blade.</p> 

Step	Procedure
<p><b>7. Remove motor and motor support</b></p>	<p>Remove the tapping screws fixing the motor and disconnect the leading wire insert of the motor. Then remove the motor.</p> <p>Remove the tapping screws fixing the motor support and lift the motor support to remove it.</p> 
<p><b>8. Remove Electric Box Assy</b></p>	<p>Remove screws fixing the electric box subassembly; loosen the wire bundle and unplug the wiring terminals. Then lift the electric box to remove it.</p> 
<p><b>9. Remove isolation sheet</b></p>	<p>Remove the screws fixing the isolation sheet and then remove the isolation sheet.</p> 

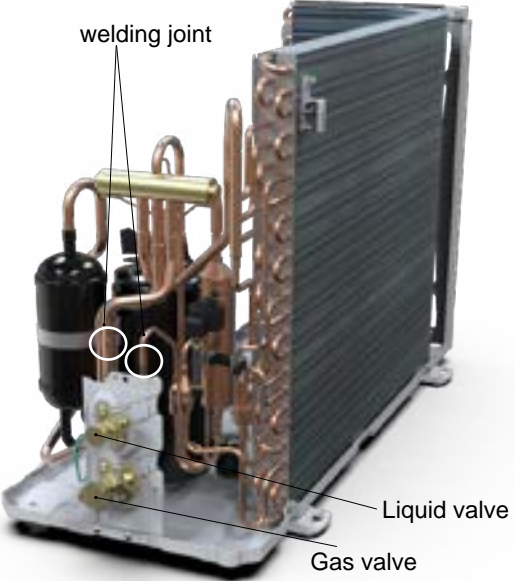
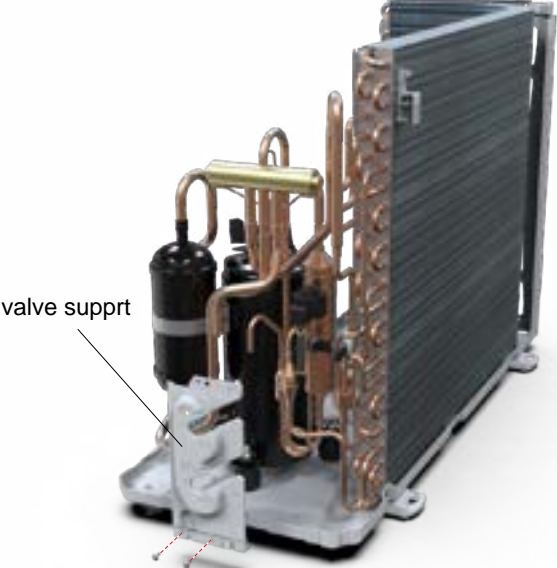
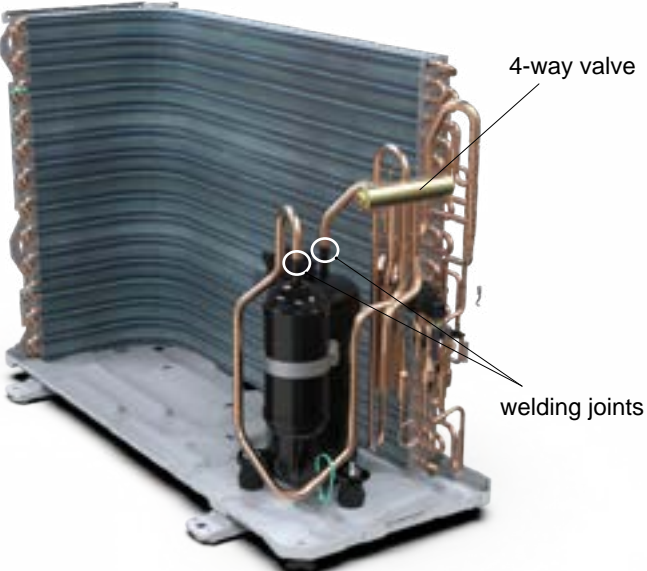

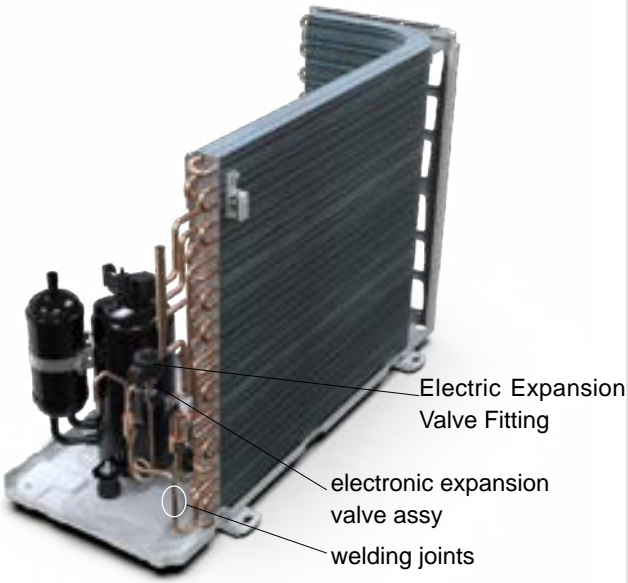
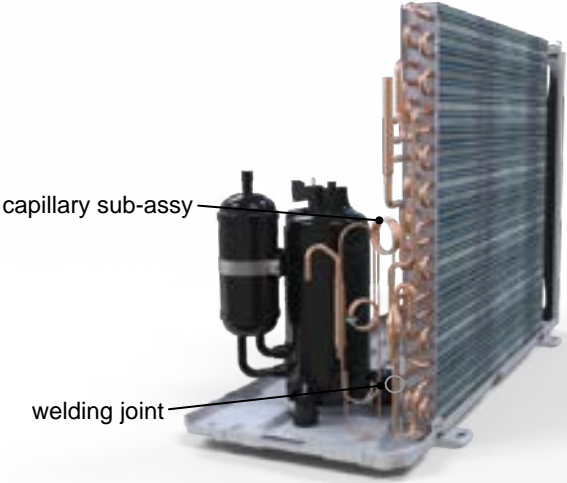
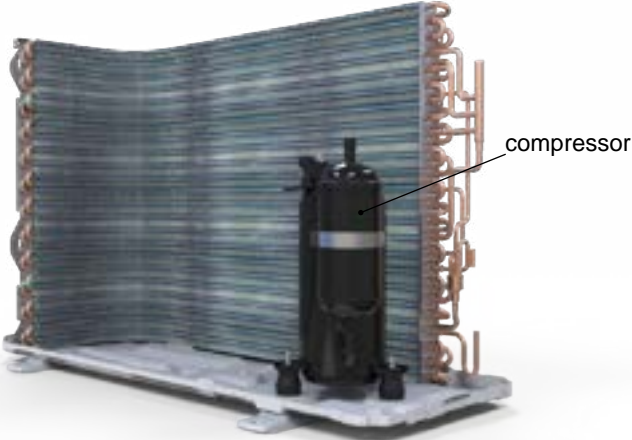
Step	Procedure
<p><b>10. Remove liquid valve and gas valve</b></p> <p>Unsolder the welding joint connecting the valve with capillary and condenser; unsolder the welding joint connecting the gas valve and air-return pipe; remove the 2 screws fixing the gas valve to remove the gas valve.</p> <p>Unsolder the welding joint connecting the liquid valve and Y-shaped pipe; remove the 2 screws fixing the liquid valve to remove the liquid valve.</p> <p>Note: Before unsoldering the welding joint, wrap the gas valve with a wet cloth completely to avoid damage to the valve caused by high temperature.</p>	 <p>The diagram shows a refrigeration unit with its condenser coils on the right. On the left, the gas and liquid valves are mounted. A label 'welding joint' points to the connection between the valves and the capillary tube. Another label 'Liquid valve' points to the valve on the left, and 'Gas valve' points to the valve on the right. Two white circles highlight the specific welding joints to be removed.</p>
<p><b>11. Remove valve support</b></p> <p>Remove the screws fixing valve support, then remove the valve support.</p>	 <p>The diagram shows the same refrigeration unit. A label 'valve support' points to the metal bracket that holds the valves in place. A red dashed line indicates the removal path of the support.</p>
<p><b>12. Remove 4-way valve assy and cut-off valve</b></p> <p>Unsolder the welding joints connecting the 4-way valve assy and cut-off valve, remove the 4-way valve and cut-off valve.</p> <p>Note: Before unsoldering the welding joint, wrap the 4-way valve with a wet cloth completely to avoid damage to the valve caused by high temperature.</p>	 <p>The diagram shows the refrigeration unit with the condenser coils on the left. The 4-way valve and cut-off valve are on the right. A label '4-way valve' points to the valve assembly, and 'welding joints' points to the connections between the valve and the capillary tube. Two white circles highlight the specific welding joints to be removed.</p>

Step	Procedure
<p><b>13. Remove electronic expansion valve assy (capillary Sub-assy)</b></p> <p><b>For electronic expansion valve models:</b> Unsolder the welding joints connecting electronic expansion valve assy then remove the electronic expansion valve assy.</p> <p><b>For capillary models:</b> Unsolder the welding joint connecting the capillary sub-assy and then remove the capillary sub-assy.</p>	 
<p><b>14. Remove compressor</b></p> <p>Remove the 3 foot nuts on the compressor and then remove the compressor.</p>	



XF: Take heat pump for example.

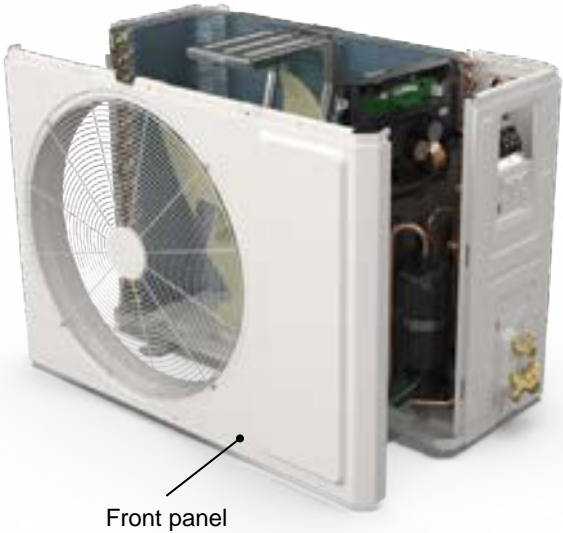
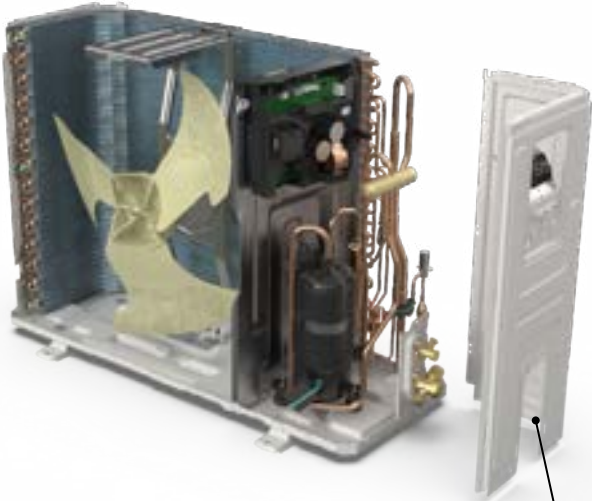
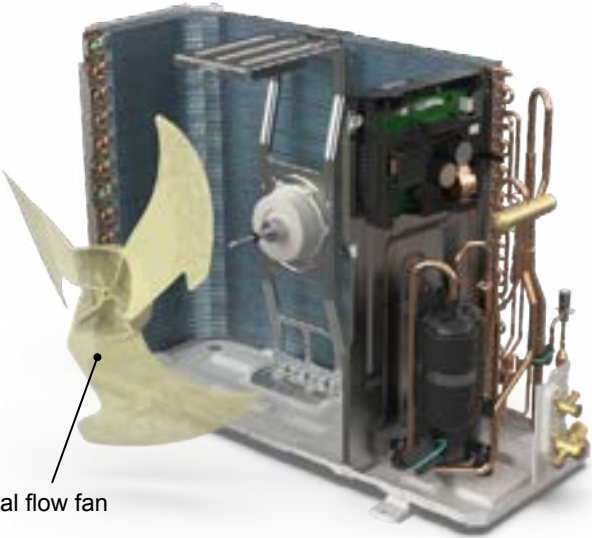

**Warning: Before disassembly, please disconnect the power supply. Before disconnection the pipeline, please discharge all the refrigerant according to the local laws and regulations.**

Step	Procedure
<b>1. Before disassembly</b>	
<b>2. Remove Cover of Pass Wire and valve cover</b>	<p data-bbox="191 1137 789 1196">Remove the screws fixing Cover of Pass Wire, valve cover and then remove them.</p> 
<b>3. Remove top cover</b>	<p data-bbox="191 1720 789 1779">Remove the screws fixing top panel and then remove the top panel.</p> 

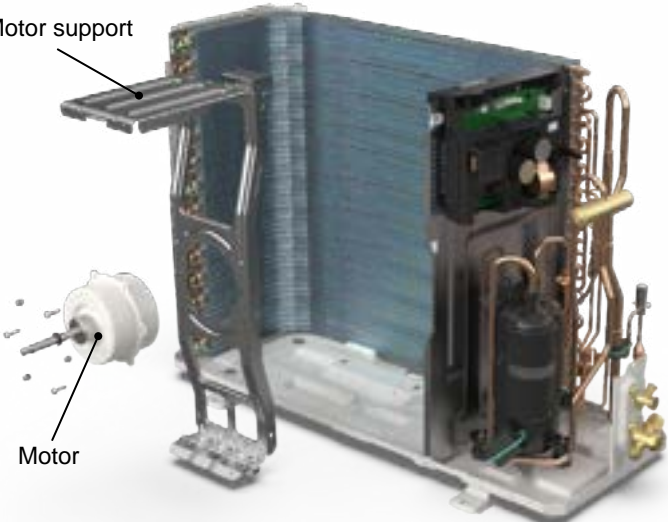
Step	Procedure
<p><b>4. Remove front panel assy</b></p>	<p>Remove connection screws connecting the front panel assy, and then remove the front panel assy.</p> 
<p><b>5. Remove right side plate assy</b></p>	<p>Rescrew the ground screws, remove the ground wires, loosen the screws fixing terminal board, remove the terminal board, rescrew the screws fixing the right side plate, and remove the right side plate assy.</p> 
<p><b>6. Remove axial flow fan</b></p>	<p>Remove the nut on the fan and then remove the axial flow fan.</p> 

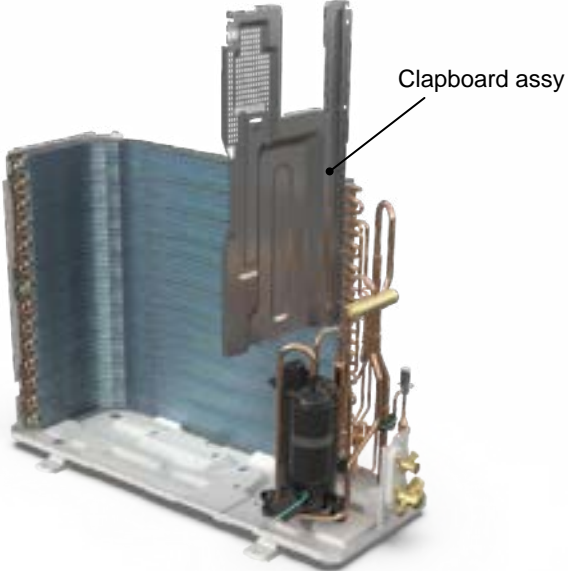
Step	Procedure
<p><b>7. Remove motor and motor support</b></p>	<p>Remove the screws fixing the motor and then remove the motor. Remove the screws fixing the motor support and lift the motor support to remove it.</p> 
<p><b>8. Remove electric box assy</b></p>	<p>Remove the terminals, lift up and rotate the electrical box assy to the right so that the snaps on the clapboard are removed and the electrical box assy are removed.</p> 
<p><b>9. Remove clapboard assy</b></p>	<p>Remove the screws fixing the clapboard assy and then remove the clapboard assy.</p> 

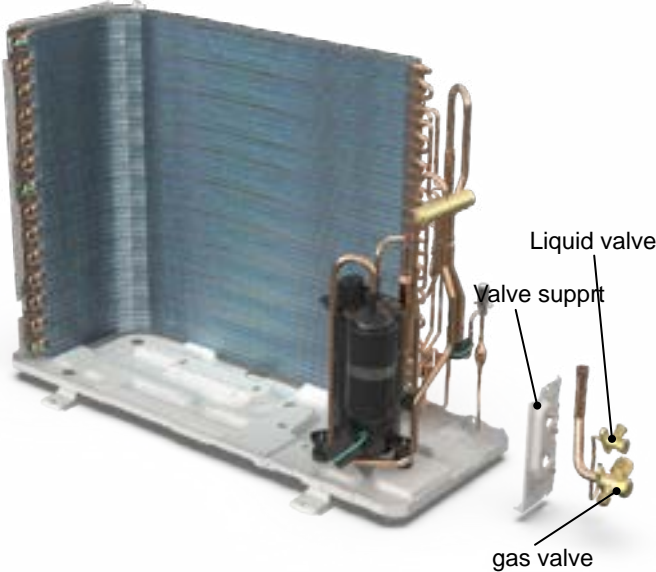
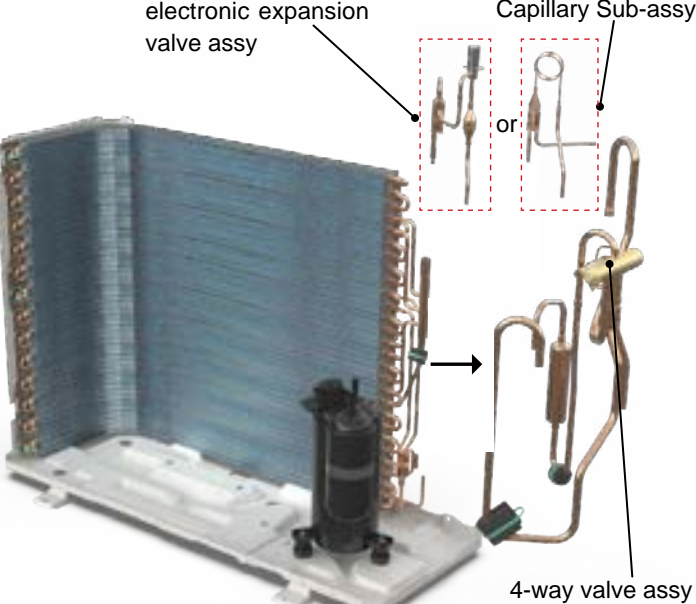
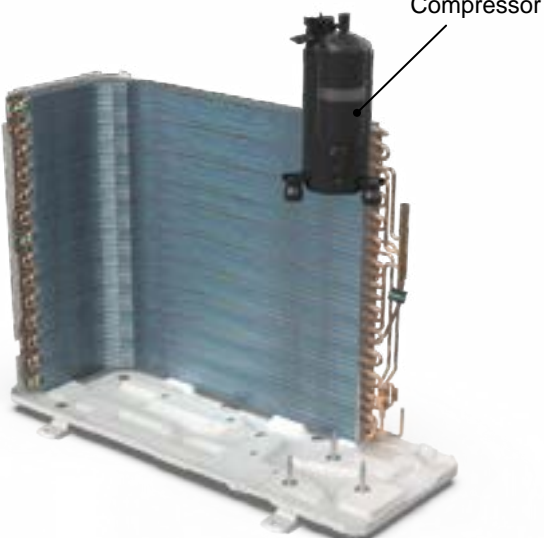

Step	Procedure
<p><b>10. Remove gas valve, liquid valve and valve support</b></p>	<p>Remove the valve support block, remove the screws fixing the gas valve and the liquid valve, unsolder the welding joint connecting the gas valve and the liquid valve, remove them.</p> <p>Note: Discharge the refrigerant completely before unsoldering; when unsoldering, wrap the gas valve with a wet cloth completely to avoid damage to the valve caused by high temperature.</p> <p>Remove the screws fixing valve support, then remove the valve support.</p> 
<p><b>11. Remove 4-way valve assy, electronic expansion valve assy(Capillary Sub-assy )</b></p>	<p>Unsolder the welding joints connecting the 4-way valve assy, remove the 4-way valve.</p> <p>Unsolder the spot weld of Capillary Sub-assy and condenser, and then remove the Capillary Sub-assy.</p> <p>Unsolder the spot weld of electronic expansion valve assy and condenser, and then remove the electronic expansion valve assy.</p> <p>Note: Before unsoldering the welding joint, wrap the 4-way valve with a wet cloth completely to avoid damage to the valve caused by high temperature.</p> 
<p><b>13. Remove compressor</b></p>	<p>Remove the 3 foot nuts on the compressor and then remove the compressor.</p> 



XH :Take the heat pump for example



**Warning: Before disassembly, please disconnect the power supply. Before disconnection the pipeline, please discharge all the refrigerant according to the local laws and regulations.**

Step	Procedure
<b>1. Before disassembly</b>	
<b>2. Remove big handle and valve cover</b>	<p data-bbox="191 1153 789 1218">Remove the screws fixing big handle, valve cover and then remove them.</p> 
<b>3. Remove top cover</b>	<p data-bbox="191 1749 789 1814">Remove the screws fixing top panel and then remove the top panel.</p> 

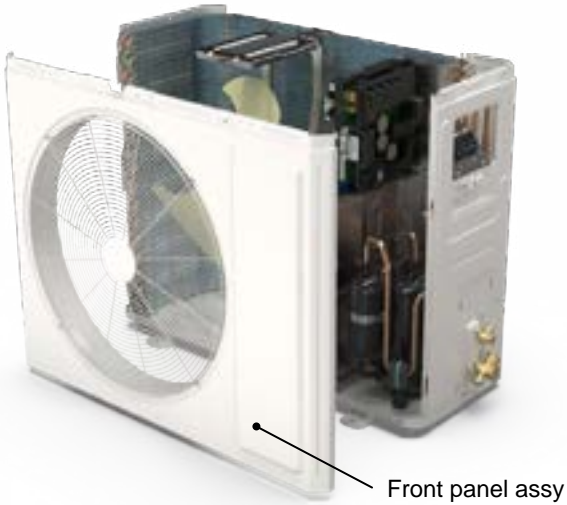
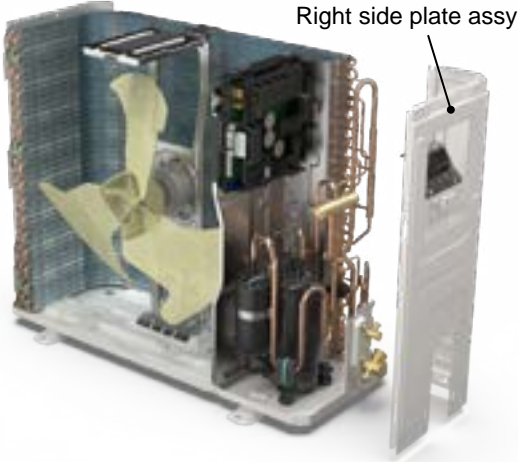
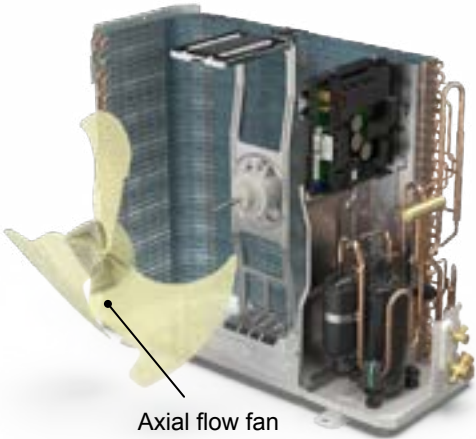
Step	Procedure
<p><b>4. Remove front panel assy</b></p>	<p>Remove connection screws connecting the front panel assy with the chassis and the motor support, and then remove the front panel assy.</p> 
<p><b>5. Remove right side plate assy</b></p>	<p>Rescrew the ground screws, remove the ground wires, loosen the screws fixing terminal board, remove the terminal board, rescrew the screws fixing the right plate, and remove the right side plate assy.</p> 
<p><b>6. Remove axial flow fan</b></p>	<p>Remove the nut on the fan and then remove the axial flow fan.</p> 

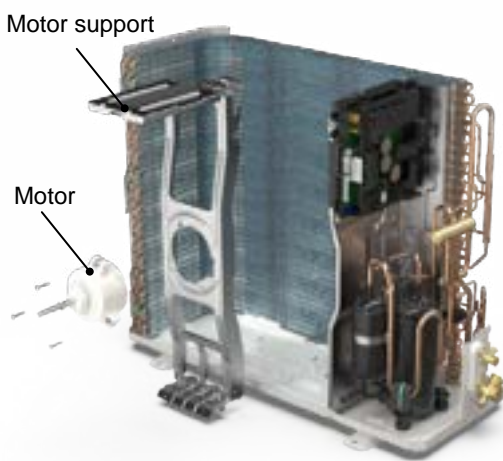
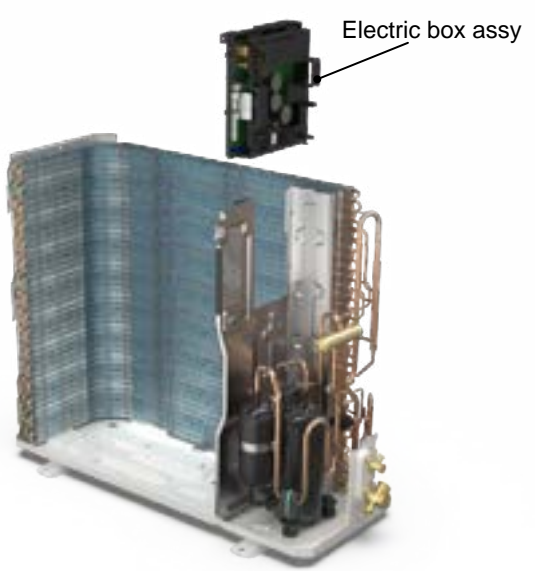
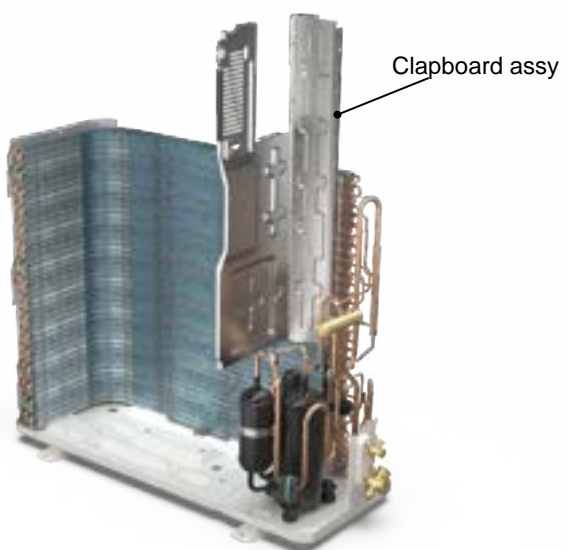
Step	Procedure
<p><b>7. Remove motor support and motor</b></p>	<p>Remove the screws fixing the motor support and lift the motor support to remove it. Remove the screws fixing the motor and then remove the motor.</p> 
<p><b>8. Remove electric box assy</b></p>	<p>Remove the terminals, lift up and rotate the electrical box assy to the right so that the snaps on the clapboard are removed and the electrical box assy are removed.</p> 
<p><b>9. Remove clapboard assy</b></p>	<p>Remove the screws fixing the clapboard assy and then remove the clapboard assy.</p> 

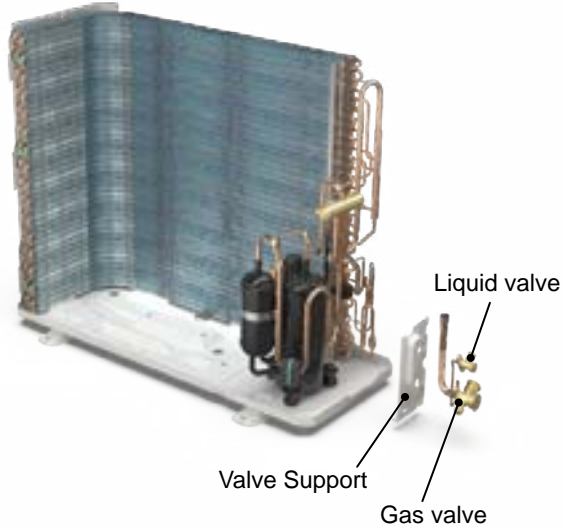
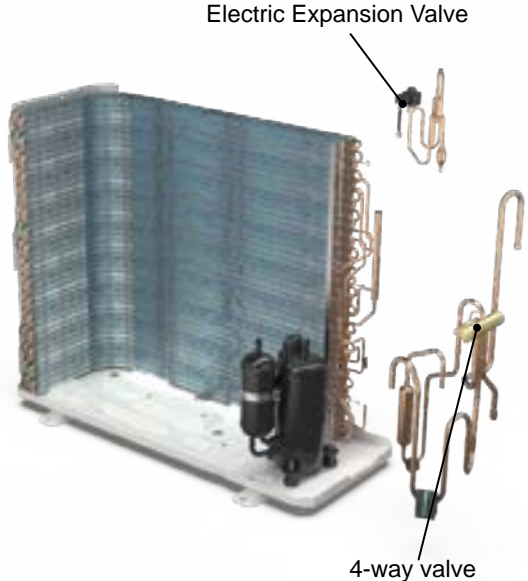
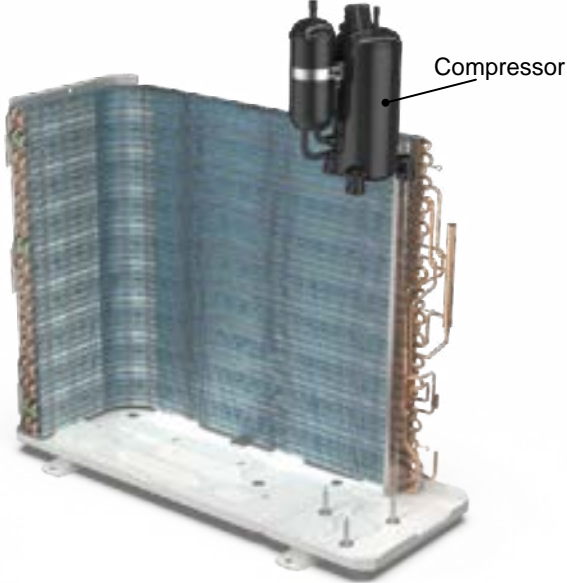
Step	Procedure
<p><b>10. Remove gas valve and liquid valve</b></p> <p>Remove the valve support block, remove the screws fixing the gas valve and the liquid valve, unsolder the welding joint connecting the gas valve and the liquid valve, remove them.</p> <p>Note: Discharge the refrigerant completely before unsoldering; when unsoldering, wrap the gas valve with a wet cloth completely to avoid damage to the valve caused by high temperature.</p>	 <p>The diagram shows a 3D perspective of the evaporator assembly. A metal plate, labeled 'Valve Support', is positioned behind the evaporator coils. Two valves are attached to the coils: a 'Gas valve' and a 'Liquid valve'. The valves are connected to the coils via copper piping. The diagram illustrates the process of removing these valves from the assembly.</p>
<p><b>11. Remove 4-way valve and electric expansion valve</b></p> <p>Unsolder the welding joints connecting the 4-way valve and electric expansion valve, and then remove them.</p>	 <p>The diagram shows the evaporator assembly with the 'Electric Expansion Valve' and '4-way valve' highlighted. The electric expansion valve is a small component with a solenoid coil, and the 4-way valve is a larger component with four ports. The diagram illustrates the process of unsoldering the welding joints connecting these valves to the evaporator coils and then removing them.</p>
<p><b>12. Remove compressor</b></p> <p>Remove the 3 foot nuts on the compressor and then remove the compressor.</p>	 <p>The diagram shows the evaporator assembly with the 'Compressor' highlighted. The compressor is a large, cylindrical component with two ports. It is mounted on the evaporator coils. The diagram illustrates the process of removing the compressor from the assembly.</p>

# Appendix

## Appendix 1: Reference Sheet of Celsius and Fahrenheit

Conversion formula for Fahrenheit degree and Celsius degree:  $T_f = T_c \times 1.8 + 32$

### Set temperature

Fahrenheit display temperature (°F)	Fahrenheit (°F)	Celsius (°C)	Fahrenheit display temperature (°F)	Fahrenheit (°F)	Celsius (°C)	Fahrenheit display temperature (°F)	Fahrenheit (°F)	Celsius (°C)
61	60.8	16	69/70	69.8	21	78/79	78.8	26
62/63	62.6	17	71/72	71.6	22	80/81	80.6	27
64/65	64.4	18	73/74	73.4	23	82/83	82.4	28
66/67	66.2	19	75/76	75.2	24	84/85	84.2	29
68	68	20	77	77	25	86	86	30

### Ambient temperature

Fahrenheit display temperature (°F)	Fahrenheit (°F)	Celsius (°C)	Fahrenheit display temperature (°F)	Fahrenheit (°F)	Celsius (°C)	Fahrenheit display temperature (°F)	Fahrenheit (°F)	Celsius (°C)
32/33	32	0	55/56	55.4	13	79/80	78.8	26
34/35	33.8	1	57/58	57.2	14	81	80.6	27
36	35.6	2	59/60	59	15	82/83	82.4	28
37/38	37.4	3	61/62	60.8	16	84/85	84.2	29
39/40	39.2	4	63	62.6	17	86/87	86	30
41/42	41	5	64/65	64.4	18	88/89	87.8	31
43/44	42.8	6	66/67	66.2	19	90	89.6	32
45	44.6	7	68/69	68	20	91/92	91.4	33
46/47	46.4	8	70/71	69.8	21	93/94	93.2	34
48/49	48.2	9	72	71.6	22	95/96	95	35
50/51	50	10	73/74	73.4	23	97/98	96.8	36
52/53	51.8	11	75/76	75.2	24	99	98.6	37
54	53.6	12	77/78	77	25			

## Appendix 2: Configuration of Connection Pipe

1. Standard length of connection pipe (More details please refer to the specifications.)

2. Min. length of connection pipe is 3m.

3. Max. length of connection pipe and max. high difference. (More details please refer to the specifications.)

4. The additional refrigerant oil and refrigerant charging required after prolonging connection pipe

- After the length of connection pipe is prolonged for 10m at the basis of standard length, you should add 5ml of refrigerant oil for each additional 5m of connection pipe.
- The calculation method of additional refrigerant charging amount (on the basis of liquid pipe):
- Basing on the length of standard pipe, add refrigerant according to the requirement as shown in the table. The additional refrigerant charging amount per meter is different according to the diameter of liquid pipe. See the following sheet.
- Additional refrigerant charging amount = prolonged length of liquid pipe X additional refrigerant charging amount per meter

Additional refrigerant charging amount for R32			
Liquid pipe	Gas pipe	Cooling only(g/m)	Cooling and heating(g/m)
1/4"	3/8" or 1/2"	12	16
1/4" or 3/8"	5/8" or 3/4"	12	40
1/2"	3/4" or 7/8"	24	96
5/8"	1" or 1 1/4"	48	96
3/4"	/	200	200
7/8"	/	280	280

# Appendix

## Appendix 3: Pipe Expanding Method

### ⚠ Note:

Improper pipe expanding is the main cause of refrigerant leakage. Please expand the pipe according to the following steps:

#### A: Cut the pipe

- Confirm the pipe length according to the distance of indoor unit and outdoor unit.
- Cut the required pipe with pipe cutter.

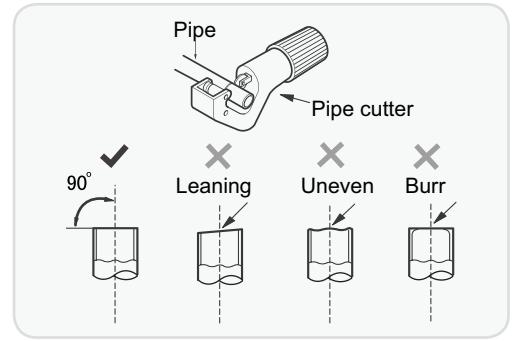

#### B: Remove the burrs

- Remove the burrs with shaper and prevent the burrs from getting into the pipe.

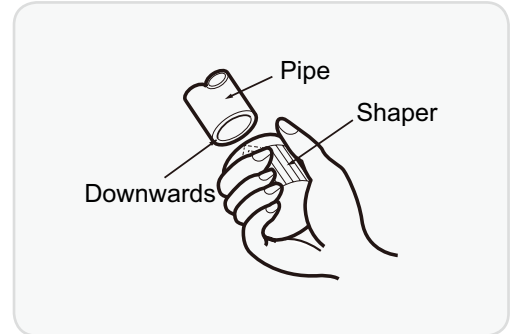

#### C: Put on suitable insulating pipe.

#### D: Put on the union nut

- Remove the union nut on the indoor connection pipe and outdoor valve; install the union nut on the pipe.

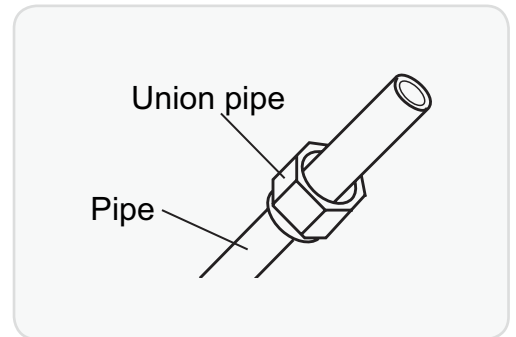

#### E: Expand the port

- Expand the port with expander.

### ⚠ Note:

- "A" is different according to the diameter, please refer to the sheet below:

Outer diameter(mm)	A(mm)	
	Max	Min
Φ6 - 6.35 (1/4")	1.3	0.7
Φ9 - Φ9.52 (3/8")	1.6	1.0
Φ12 - 12.70 (1/2")	1.8	1.0
Φ16 - 15.88 (5/8")	2.4	2.2

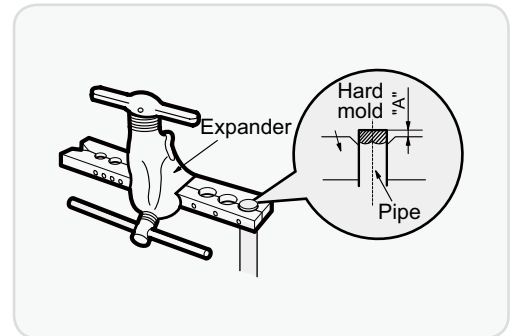

#### F: Inspection

- Check the quality of expanding port. If there is any blemish, expand the port again according to the steps above.

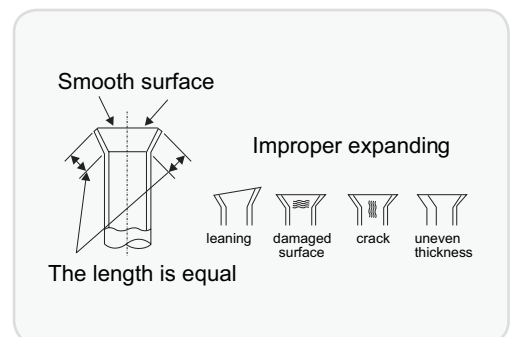

# Appendix

## Appendix 4: List of Resistance for Temperature Sensor

### Resistance Table of Ambient Temperature Sensor for Indoor and Outdoor Units(15K)

Temp(°C)	Resistance(kΩ)
-19	138.10
-18	128.60
-16	115.00
-14	102.90
-12	92.22
-10	82.75
-8	74.35
-6	66.88
-4	60.23
-2	54.31

Temp(°C)	Resistance(kΩ)
0	49.02
2	44.31
4	40.09
6	36.32
8	32.94
10	29.90
12	27.18
14	24.73
16	22.53
18	20.54

Temp(°C)	Resistance(kΩ)
20	18.75
22	17.14
24	15.68
26	14.36
28	13.16
30	12.07
32	11.09
34	10.20
36	9.38
38	8.64

Temp(°C)	Resistance(kΩ)
40	7.97
42	7.35
44	6.79
46	6.28
48	5.81
50	5.38
52	4.99
54	4.63
56	4.29
58	3.99

### Resistance Table of Tube Temperature Sensors for Indoor and Outdoor (20K)

Temp(°C)	Resistance(kΩ)
-19	181.40
-15	145.00
-10	110.30
-5	84.61
0	65.37
5	50.87
10	39.87
15	31.47

Temp(°C)	Resistance(kΩ)
20	25.01
25	20.00
30	16.10
35	13.04
40	10.62
45	8.71
50	7.17
55	5.94

Temp(°C)	Resistance(kΩ)
60	4.95
65	4.14
70	3.48
75	2.94
80	2.50
85	2.13
90	1.82
95	1.56

Temp(°C)	Resistance(kΩ)
100	1.35
105	1.16
110	1.01
115	0.88
120	0.77
125	0.67
130	0.59
135	0.52

### Resistance Table of Discharge Temperature Sensor for Outdoor(50K)

Temp(°C)	Resistance(kΩ)
-30	911.400
-25	660.8
-20	486.5
-15	362.9
-10	274
-5	209
0	161
5	125.1

Temp(°C)	Resistance(kΩ)
10	98
15	77.35
20	61.48
25	49.19
30	39.61
35	32.09
40	26.15
45	21.43

Temp(°C)	Resistance(kΩ)
50	17.65
55	14.62
60	12.17
65	10.18
70	8.555
75	7.224
80	6.129
85	5.222

Temp(°C)	Resistance(kΩ)
90	4.469
95	3.841
100	3.315
105	2.872
110	2.498
115	2.182
120	1.912
125	1.682



JF00305570



GREE ELECTRIC APPLIANCES, INC. OF ZHUHAI

Add: West Jinji Rd, Qianshan, Zhuhai, Guangdong, China, 519070  
Tel: (+86-756) 8522219  
Fax: (+86-756) 8669426  
E-mail: [global@cn.gree.com](mailto:global@cn.gree.com)

**PTAC DIRECT SALES, INC.**  
**185 S. KIMBALL AVE., SUITE 130**  
**SOUTHLAKE, TX 76092**  
**877.454.7822**  
**[www.PTACdirect.com](http://www.PTACdirect.com)**

**For product improvement, specifications and appearance in this manual are subject to change without prior notice.**